

UNCONTROLLED DOCUMENT

PART NUMBER  
SSL-LX5099SIUSBW

REV.  
A

REV.	E.C.N. NUMBER AND REVISION COMMENTS	DATE
A	E.C.N. #11148	11.08.06

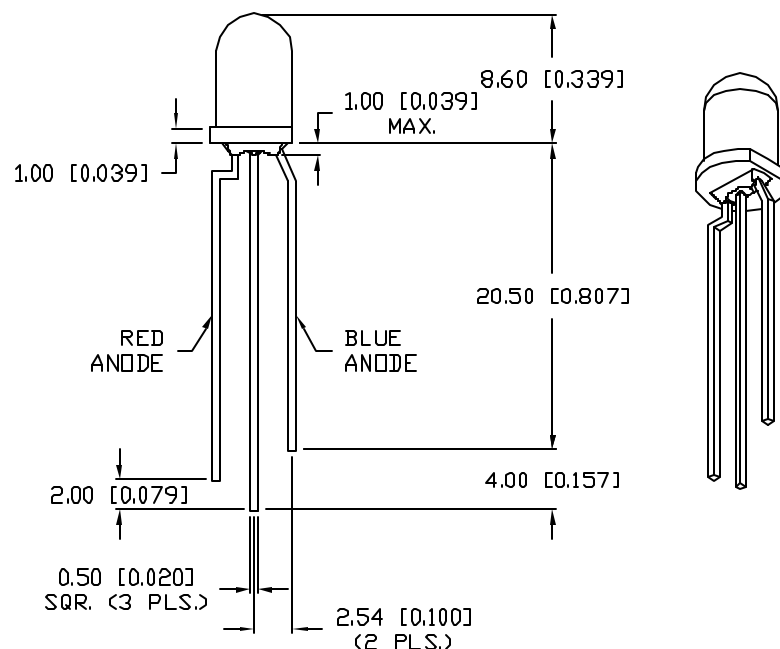
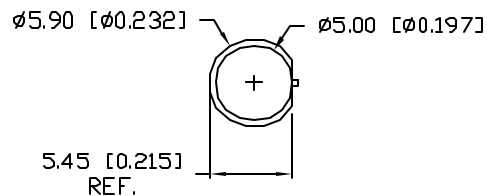

ELECTRO-OPTICAL CHARACTERISTICS  $T_A=25^\circ\text{C}$   $I_f=20\text{mA}$

PARAMETER	MIN	TYP	MAX	UNITS	TEST COND
PEAK WAVELENGTH		636 (RED)		nm	
		470 (BLUE)		nm	
FORWARD VOLTAGE (R/B)		2.0/3.5	2.5/4.0	$V_f$	
REVERSE VOLTAGE	5.0			$V_r$	$I_f=100\mu\text{A}$
AXIAL INTENSITY (R/B)		100/80		mcd	$I_f=20\text{mA}$
VIEWING ANGLE		60		2x theta	
EMITTED COLOR:	RED/BLUE				
EPOXY LENS FINISH:	MILKY WHITE DIFFUSED				

LIMITS OF SAFE OPERATION AT  $25^\circ\text{C}$

PARAMETER	COLORS	MAX	UNITS
PEAK FORWARD CURRENT*	(R/B)	185/150	mA
STEADY CURRENT	(R/B)	30/25	mA
POWER DISSIPATION	(R/B)	170/120	mW
DERATE FROM $25^\circ\text{C}$		-1.2	mW/ $^\circ\text{C}$
OPERATING, STORAGE TEMP.		-40 TO +85	$^\circ\text{C}$
SOLDERING TEMP.		+260	$^\circ\text{C}$
2.0mm FROM BODY			3 SEC. MAX

\*  $t < 10\mu\text{s}$



\*UNLESS OTHERWISE SPECIFIED TOLERANCES PER DECIMAL PRECISION ARE: X=±1 (±0.039), X.X=±0.5 (±0.020), X.XX=±0.25 (±0.010), X.XXX=±0.127 (±0.005), LEAD SIZE=±0.08 (±0.002), LEAD LENGTH=±0.75 (±0.030), MIN= <sup>+0.00</sup> <sub>-0.00</sub> DECIMAL PRECISION MAX.= <sup>+0.00</sup> <sub>-0.00</sub> DECIMAL PRECISION

UNCONTROLLED DOCUMENT

REV. A PART NUMBER SSL-LX5099SIUSBW

CONFIDENTIAL INFORMATION  
THE INFORMATION CONTAINED IN THIS DOCUMENT IS THE PROPERTY OF LUMEX INC. EXCEPT AS SPECIFICALLY AUTHORIZED IN WRITING BY LUMEX INC, THE HOLDER OF THIS DOCUMENT SHALL KEEP ALL INFORMATION CONTAINED HEREIN CONFIDENTIAL AND SHALL PROTECT SAME IN WHOLE OR IN PART FROM DISCLOSURE AND DISSEMINATION TO ALL THIRD PARTIES.



290 E. HELEN ROAD  
PALATINE, IL 60067-6976  
PHONE: +1.847.359.2790  
US WEB: www.lumex.com  
TW WEB: www.lumex.com.tw

T-5mm 3 LEADED BICOLOR LED,  
636nm AlInGaP RED, 470nm InGaN BLUE,  
MILKY WHITE DIFFUSED LENS.

RELIABILITY NOTE  
OUR MANY YEARS OF EXPERIENCE DATA ACCUMULATION INDICATE THAT SOLDER HEAT IS A MAJOR CAUSE OF EARLY AND FUTURE FAILURE. PLEASE PAY ATTENTION TO YOUR SOLDERING PROCESS.

DRAWN BY: JC	CHECKED BY:	APPROVED BY:	DATE: 11.08.06
			PAGE: 1 OF 1
			SCALE: N/A