

PART NUMBER	SSL-LX5093LAD	REV.	B
DATE	E.C.N. NUMBER AND REVISION COMMENTS		REV.
10.23.06	E.C.N. #11148.		A
02.16.12	E.C.N. #10BRDR. & REDRAWN.		B

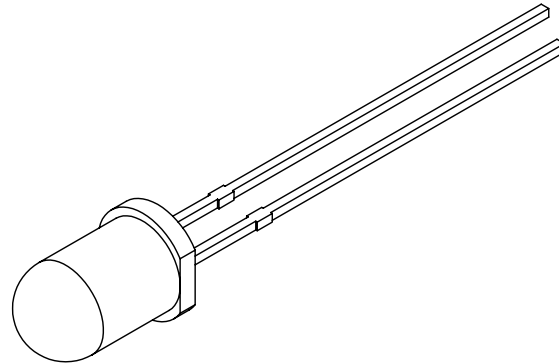
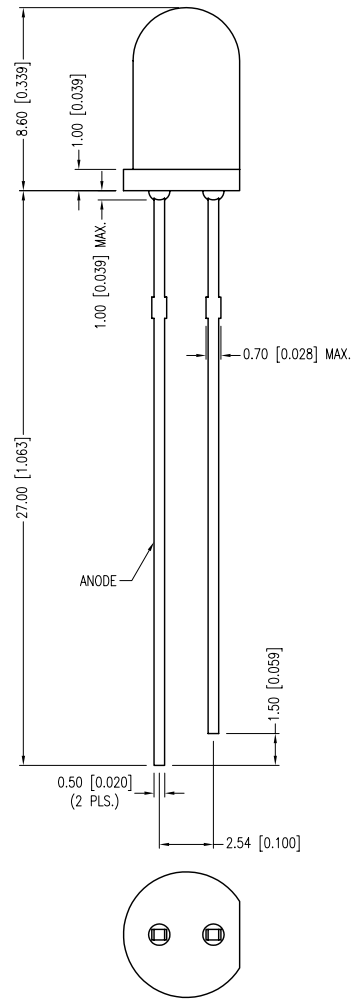
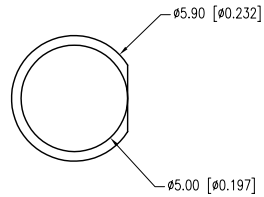

ELECTRO-OPTICAL CHARACTERISTICS $T_a=25^\circ\text{C}$ $I_f=20\text{mA}$					
PARAMETER	MIN	TYP	MAX	UNITS	TEST COND
PEAK WAVELENGTH		605		nm	
FORWARD VOLTAGE		2.0	2.5	Vf	
REVERSE VOLTAGE	5.0			Vr	$I_f=100\mu\text{A}$
AXIAL INTENSITY		40		mcd	$I_f=20\text{mA}$
	1.0			mcd	$I_f=2\text{mA}$
VIEWING ANGLE		60		2x theta	
EMITTED COLOR:	AMBER				
EPOXY LENS FINISH:	AMBER DIFFUSED				

LIMITS OF SAFE OPERATION AT $25^\circ\text{C}$		
PARAMETER	MAX	UNITS
PEAK FORWARD CURRENT*	150	mA
STEADY CURRENT	30	mA
POWER DISSIPATION	105	mW
DERATE FROM $25^\circ\text{C}$	-1.2	mW/ $^\circ\text{C}$
OPERATING TEMP.	-40 TO +85	$^\circ\text{C}$
STORAGE TEMP.	-40 TO +85	$^\circ\text{C}$
SOLDERING TEMP.	+260	$^\circ\text{C}$
2.0mm FROM BODY	3	SEC.

\*  $t < 10\mu\text{s}$

\*UNLESS OTHERWISE SPECIFIED TOLERANCES PER DECIMAL PRECISION ARE: X= $\pm 1$  ( $\pm 0.039$ ), X.X= $\pm 0.5$  ( $\pm 0.020$ ), X.XX= $\pm 0.25$  ( $\pm 0.010$ ), X.XXX= $\pm 0.127$  ( $\pm 0.005$ ). LEAD SIZE= $\pm 0.05$  ( $\pm 0.002$ ), LEAD LENGTH= $\pm 0.75$  ( $\pm 0.030$ ). MIN=  $\begin{matrix} +0.00 \\ -0.00 \end{matrix}$  DECIMAL PRECISION MAX.=  $\begin{matrix} +0.00 \\ -0.00 \end{matrix}$  DECIMAL PRECISION

**LUMEX**  
 Creating LED and LCD Solutions Together™  
 290 E. HELEN ROAD  
 PALATINE, IL 60067-6976  
 PHONE: +1.847.359.2790  
 FAX: +1.847.359.6538  
 WEB: WWW.LUMEX.COM

T-5mm (T-1 3/4) 605nm AMBER LED, AMBER DIFFUSED LENS, LOW CURRENT SELECTION.

\*\*THE SPECIFICATIONS MAY CHANGE AT ANY TIME WITHOUT NOTICE DUE TO NEW MATERIALS OR PRODUCT IMPROVEMENT.\*\*

CONFIDENTIAL INFORMATION  
 THE INFORMATION CONTAINED IN THIS DOCUMENT IS THE PROPERTY OF LUMEX INC. EXCEPT AS SPECIFICALLY AUTHORIZED IN WRITING BY LUMEX INC., THE HOLDER OF THIS DOCUMENT SHALL KEEP ALL INFORMATION CONTAINED HEREIN CONFIDENTIAL AND SHALL PROTECT SAME IN WHOLE OR IN PART FROM DISCLOSURE AND DISSEMINATION TO ALL THIRD PARTIES.

DATE:	02.16.12	DRAWN BY:	AB
PAGE:	1 OF 1	CHKD BY:	DT
SCALE:	NTS	APRVD BY:	KF
UNIT:	mm [INCH]		Ⓟ