

UNCONTROLLED DOCUMENT

PART NUMBER		REV.
SSL-LX5093GHW		C
REV.	E.C.N. NUMBER AND REVISION COMMENTS	DATE
A	REDRAWN.	7.9.92
B	UPDATED SPECS.	9.12.95
C	E.C.N. #10BRDR. & REDRAWN IN 3D.	5.29.01

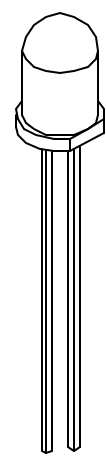
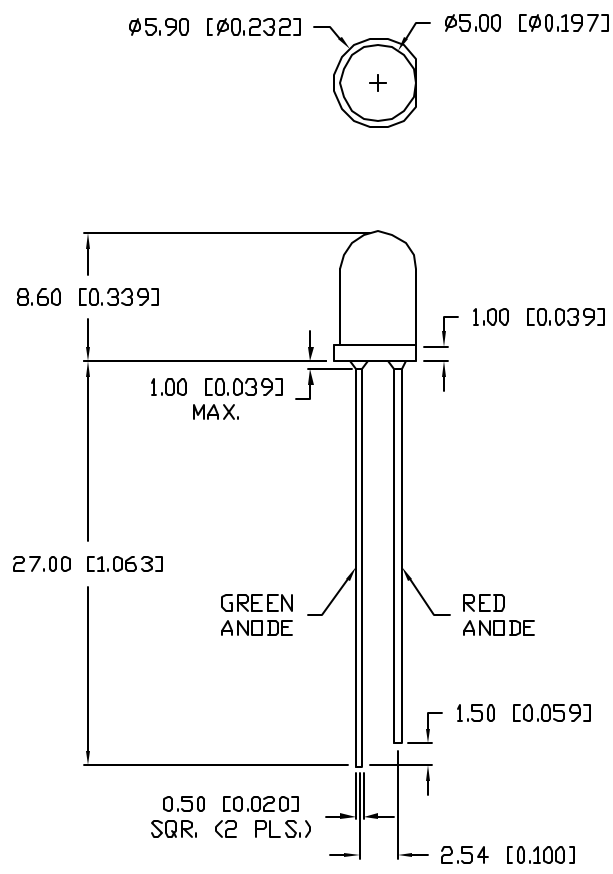

ELECTRO-OPTICAL CHARACTERISTICS  $T_A=25^\circ\text{C}$   $I_f=20\text{mA}$

PARAMETER	MIN	TYP	MAX	UNITS	TEST COND
PEAK WAVELENGTH		565 (GREEN)		nm	
		700 (RED)		nm	
FORWARD VOLTAGE (G/R)		2.2/2.0	2.6/2.5	$V_f$	
REVERSE VOLTAGE	5.0			$V_r$	$I_f=100\mu\text{A}$
AXIAL INTENSITY		10		mcd	$I_f=20\text{mA}$
VIEWING ANGLE		60		2x theta	
EMITTED COLOR:	GREEN/RED				
EPOXY LENS FINISH:	MILKY WHITE DIFFUSED				

LIMITS OF SAFE OPERATION AT  $25^\circ\text{C}$

PARAMETER	COLORS	MAX	UNITS
PEAK FORWARD CURRENT*		150	mA
STEADY CURRENT		25	mA
POWER DISSIPATION	(G/R)	105/120	mW
DERATE FROM $25^\circ\text{C}$		-1.2	mW/ $^\circ\text{C}$
OPERATING, STORAGE TEMP.		-40 TO +85	$^\circ\text{C}$
SOLDERING TEMP.		+260	$^\circ\text{C}$
2.0mm FROM BODY			3 SEC. MAX

\*  $t < 10\mu\text{s}$

\*UNLESS OTHERWISE SPECIFIED TOLERANCES PER DECIMAL PRECISION ARE: X=±1 (±0.039), XX=±0.5 (±0.020), XXX=±0.25 (±0.010), XXXX=±0.127 (±0.005). LEAD SIZE=±0.05 (±0.002), LEAD LENGTH=±0.75 (±0.030), MIN. <sup>+DECIMAL PRECISION</sup> MAX. = <sup>+0.00</sup> <sub>-0.00</sub> DECIMAL PRECISION

UNCONTROLLED DOCUMENT

REV.	PART NUMBER
C	SSL-LX5093GHW

**CONFIDENTIAL INFORMATION**  
 THE INFORMATION CONTAINED IN THIS DOCUMENT IS THE PROPERTY OF LUMEX INC. EXCEPT AS SPECIFICALLY AUTHORIZED IN WRITING BY LUMEX INC., THE HOLDER OF THIS DOCUMENT SHALL KEEP ALL INFORMATION CONTAINED HEREIN CONFIDENTIAL AND SHALL PROTECT SAME IN WHOLE OR IN PART FROM DISCLOSURE AND DISSEMINATION TO ALL THIRD PARTIES.



290 E. HELEN ROAD  
 PALATINE, IL 60067-6976  
 PHONE: +1.847.359.2790  
 US WEB: www.lumex.com  
 TW WEB: www.lumex.com.tw

T-5mm (T-1 3/4) 565nm GREEN/700nm RED LED,  
 MILKY WHITE DIFFUSED LENS.

**RELIABILITY NOTE**  
 OUR MANY YEARS OF EXPERIENCE DATA ACCUMULATION INDICATE THAT SOLDER HEAT IS A MAJOR CAUSE OF EARLY AND FUTURE FAILURE. PLEASE PAY ATTENTION TO YOUR SOLDERING PROCESS.

DRAWN BY:	CHECKED BY:	APPROVED BY:	DATE: 12.19.90
BC			PAGE: 1 OF 1
			SCALE: N/A