

UNCONTROLLED DOCUMENT

PART NUMBER		REV.
SSL-LX5093BSBD/A		A
REV.	E.C.N. NUMBER AND REVISION COMMENTS	DATE
A	E.C.N. #10283	12.11.96
B	E.C.N. #10BRDR & REDRAWN IN 3D	5.31.01
C	E.C.N. #11148	10.18.06

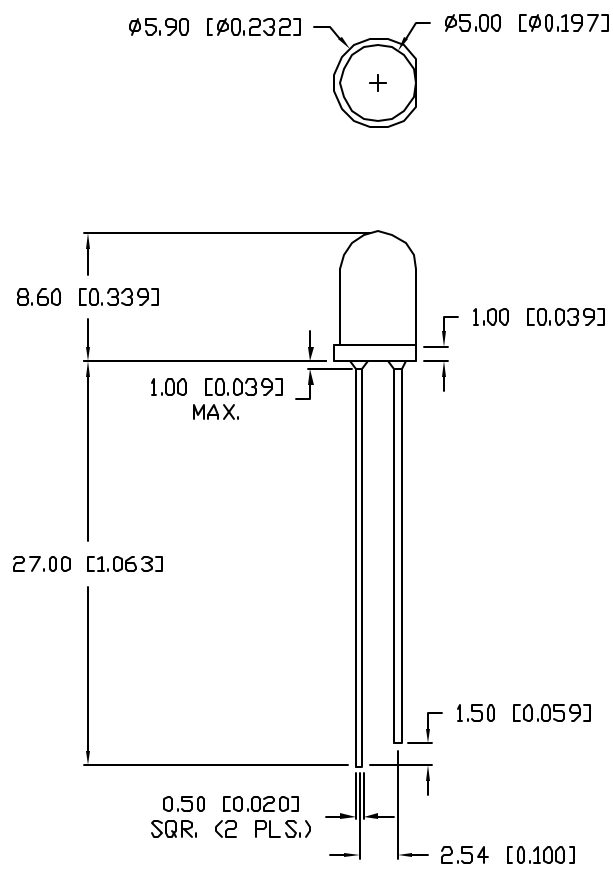

ELECTRO-OPTICAL CHARACTERISTICS  $T_A=25^\circ\text{C}$

PARAMETER	MIN	TYP	MAX	UNITS	TEST COND
PEAK WAVELENGTH		430		nm	
FORWARD VOLTAGE		3.0	14.0	$V_f$	
BLINKING FREQUENCY:		3		Hz	$V_f=3.5, I_f=70\text{mA}$
		1.5		Hz	$V_f=14, I_f=6\text{mA}$
AXIAL INTENSITY		45		mod	$V_f=9.0$
VIEWING ANGLE		80		2x theta	
EMITTED COLOR:	BLUE				
EPOXY LENS FINISH:	BLUE DIFFUSED				

LIMITS OF SAFE OPERATION AT  $25^\circ\text{C}$  PER CHIP

PARAMETER	MAX	UNITS
STEADY CURRENT	1.7-41	$\mu\text{A}$
POWER DISSIPATION	310	mW
DERATE FROM $25^\circ\text{C}$	-1.2	$\text{mW}/^\circ\text{C}$
OPERATING TEMP.	-40 TO +70	$^\circ\text{C}$
STORAGE TEMP.	-40 TO +85	$^\circ\text{C}$
SOLDERING TEMP.	+260	$^\circ\text{C}$
2.0mm FROM BODY		5 SEC. MAX

CAUTION: STATIC SENSITIVE DEVICE  
FOLLOW PROPER E.S.D. HANDLING PROCEDURES  
WHEN WORKING WITH THIS PART.



UNCONTROLLED DOCUMENT

\*UNLESS OTHERWISE SPECIFIED TOLERANCES PER DECIMAL PRECISION ARE: X=±1 (±0.039), X.X=±0.5 (±0.020), X.XX=±0.25 (±0.010), X.XXX=±0.127 (±0.005). LEAD SIZE=±0.05 (±0.002), LEAD LENGTH=±0.75 (±0.030), MIN=+0.00 DECIMAL PRECISION MAX=-0.00 DECIMAL PRECISION

REV.	PART NUMBER
A	SSL-LX5093BSBD/A

CONFIDENTIAL INFORMATION  
THE INFORMATION CONTAINED IN THIS DOCUMENT IS THE PROPERTY OF LUMEX INC. EXCEPT AS SPECIFICALLY AUTHORIZED IN WRITING BY LUMEX INC, THE HOLDER OF THIS DOCUMENT SHALL KEEP ALL INFORMATION CONTAINED HEREIN CONFIDENTIAL AND SHALL PROTECT SAME IN WHOLE OR IN PART FROM DISCLOSURE AND DISSEMINATION TO ALL THIRD PARTIES.



290 E. HELEN ROAD  
PALATINE, IL 60067-6976  
PHONE: +1.847.359.2790  
US WEB: www.lumex.com  
TW WEB: www.lumex.com.tw

T-5mm (T-1 3/4) 430nm SUPER BLUE, BLINKING LED,  
BLUE DIFFUSED LENS.

RELIABILITY NOTE  
OUR MANY YEARS OF EXPERIENCE DATA ACCUMULATION INDICATE THAT SOLDER HEAT IS A MAJOR CAUSE OF EARLY AND FUTURE FAILURE. PLEASE PAY ATTENTION TO YOUR SOLDERING PROCESS.

DRAWN BY:	CHECKED BY:	APPROVED BY:	DATE: 10.18.06
JC			PAGE: 1 OF 1
			SCALE: N/A