

UNCONTROLLED DOCUMENT

| | | |
|---------------|-------------------------------------|--------|
| PART NUMBER | | REV. |
| SSL-LX2344SRD | | A |
| REV. | E.C.N. NUMBER AND REVISION COMMENTS | DATE |
| A | E.C.N. #10BRDR. & REDRAWN IN 3D. | 6.8.01 |

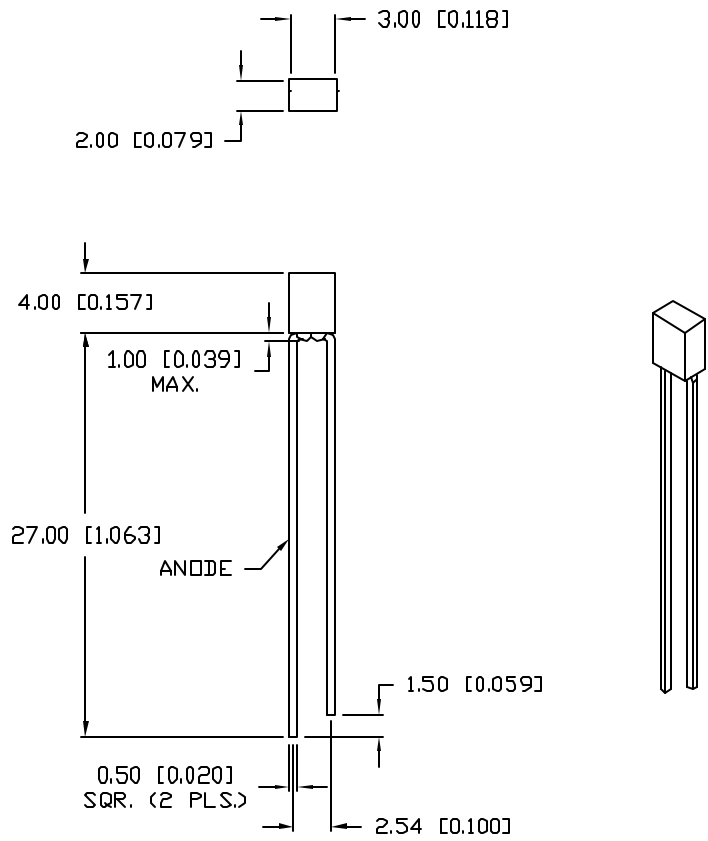

ELECTRO-OPTICAL CHARACTERISTICS $T_A=25^{\circ}\text{C}$ $I_f=20\text{mA}$

| PARAMETER | MIN | TYP | MAX | UNITS | TEST COND |
|--------------------|--------------|-----|-----|------------|----------------------|
| PEAK WAVELENGTH | | 660 | | nm | |
| FORWARD VOLTAGE | | 1.7 | 2.2 | V_f | |
| REVERSE VOLTAGE | 4.0 | | | V_r | $I_r=100\mu\text{A}$ |
| AXIAL INTENSITY | | 25 | | med | $I_f=20\text{mA}$ |
| VIEWING ANGLE | | 100 | | $2x$ theta | |
| EMITTED COLOR: | RED | | | | |
| EPOXY LENS FINISH: | RED DIFFUSED | | | | |

LIMITS OF SAFE OPERATION AT 25°C

| PARAMETER | MAX | UNITS |
|----------------------------------|------------|------------------------------|
| PEAK FORWARD CURRENT* | 150 | mA |
| STEADY CURRENT | 30 | mA |
| POWER DISSIPATION | 100 | mW |
| DERATE FROM 25°C | -1.2 | $\text{mW}/^{\circ}\text{C}$ |
| OPERATING, STORAGE TEMP. | -40 TO +85 | $^{\circ}\text{C}$ |
| SOLDERING TEMP. | +260 | $^{\circ}\text{C}$ |
| 2.0mm FROM BODY | | 3 SEC. MAX |

* $t < 10\mu\text{s}$

*UNLESS OTHERWISE SPECIFIED TOLERANCES PER DECIMAL PRECISION ARE: X=±1 (±0.039), XX=±0.5 (±0.020), XXX=±0.25 (±0.010), XXXX=±0.127 (±0.005). LEAD SIZE=±0.05 (±0.002), LEAD LENGTH=±0.75 (±0.030), MIN= ^{+DECIMAL PRECISION} -0.00 ^{MAX.= +0.00} -DECIMAL PRECISION

UNCONTROLLED DOCUMENT

| | |
|---|---------------|
| REV. | PART NUMBER |
| A | SSL-LX2344SRD |
| 2mm x 3mm RECTANGULAR, 660nm SUPER RED LED, RED DIFFUSED LENS. | |

CONFIDENTIAL INFORMATION
 THE INFORMATION CONTAINED IN THIS DOCUMENT IS THE PROPERTY OF LUMEX INC. EXCEPT AS SPECIFICALLY AUTHORIZED IN WRITING BY LUMEX INC., THE HOLDER OF THIS DOCUMENT SHALL KEEP ALL INFORMATION CONTAINED HEREIN CONFIDENTIAL AND SHALL PROTECT SAME IN WHOLE OR IN PART FROM DISCLOSURE AND DISSEMINATION TO ALL THIRD PARTIES.

RELIABILITY NOTE
 OUR MANY YEARS OF EXPERIENCE DATA ACCUMULATION INDICATE THAT SOLDER HEAT IS A MAJOR CAUSE OF EARLY AND FUTURE FAILURE. PLEASE PAY ATTENTION TO YOUR SOLDERING PROCESS.

290 E. HELEN ROAD
 PALATINE, IL 60067-6976
 PHONE: +1.847.359.2790
 US WEB: www.lumex.com
 TW WEB: www.lumex.com.tw

| | | | |
|-----------|-------------|--------------|---------------|
| DRAWN BY: | CHECKED BY: | APPROVED BY: | DATE: 12.1.95 |
| BC | | | PAGE: 1 OF 1 |
| | | | SCALE: N/A |