

DATE	REVISIONS	REV
3-10-98	E.C.N. #10BRDR. & #10421. & REDRAWN./	A

DRAWING NUMBER	REV
SSL-LX100133BID	A

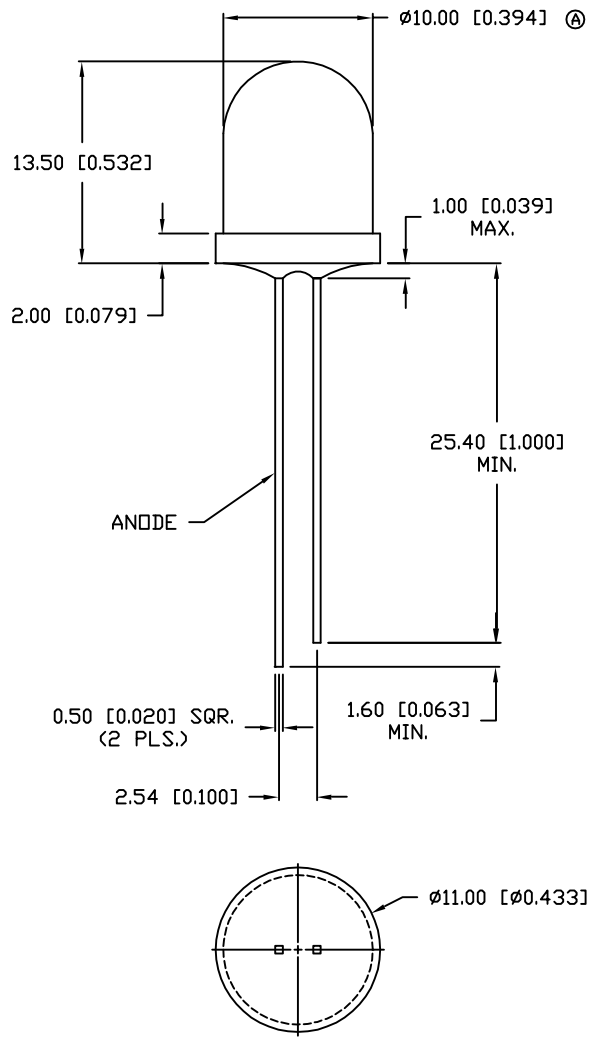

ELECTRO-OPTICAL CHARACTERISTICS $T_A=25^{\circ}\text{C}$ $V_f=9-12\text{V}$

PARAMETER	MIN	TYP	MAX	UNITS	TEST COND
PEAK WAVELENGTH		635 (RED)		nm	
FORWARD VOLTAGE	3.5	9-12	13.0	V_f	
FORWARD CURRENT	6.0	38-50	70	mA	
BLINKING FREQUENCY	2.5		1.5	Hz	
AXIAL INTENSITY		60		mcd	$V_f=9-12\text{V}$
VIEWING ANGLE		80		$2x$ theta	
EMITTED COLOR:	RED				
EPOXY LENS FINISH:	RED DIFFUSED				

LIMITS OF SAFE OPERATION AT 25°C

PARAMETER	MAX	UNITS
FORWARD VOLTAGE	13	V
REVERSE VOLTAGE	0.5	V
FORWARD CURRENT	70	mA
POWER DISSIPATION	200	mW
OPERATING, STORAGE TEMP.	-40 TO +85	$^{\circ}\text{C}$
SOLDERING TEMP.	+260	$^{\circ}\text{C}$
2.0mm FROM BODY		3 SEC. MAX

RELIABILITY NOTE

OUR MANY YEARS OF EXPERIENCE DATA ACCUMULATION INDICATE THAT SOLDER HEAT IS A MAJOR CAUSE OF EARLY AND FUTURE FAILURE. PLEASE PAY ATTENTION TO YOUR SOLDERING PROCESS.

Ⓐ



290 E. HELLEN ROAD
PALATINE, ILLINOIS 60067
(847) 359-2790

CONFIDENTIAL INFORMATION
THE INFORMATION CONTAINED IN THIS DOCUMENT IS THE PROPERTY OF LUMEX INCORPORATED. EXCEPT AS SPECIFICALLY AUTHORIZED IN WRITING BY LUMEX INCORPORATED, THE HOLDER OF THIS DOCUMENT SHALL KEEP ALL INFORMATION CONTAINED HEREIN CONFIDENTIAL AND SHALL PROTECT SAME IN WHOLE OR IN PART FROM DISCLOSURE AND DISSEMINATION TO ALL THIRD PARTIES.

DATE: 6-13-96	DWN:	CHK'D:	APPD:
SCALE: N/A			

T-3 1/8mm (T-10) LED, BLINKING RED, DIFFUSED LENS.

PAGE 1 OF 1	DRAWING NUMBER SSL-LX100133BID	REV A
-------------	-----------------------------------	----------

UNLESS OTHERWISE SPECIFIED TOLERANCE IS $\pm 0.25\text{mm}$ ($\pm 0.010''$)

DU