



EVERLIGHT ELECTRONICS CO., LTD.

DATA SHEET

MODEL NO : PT5529B/L2/S3

DATE : 08-29-2005

DEPARTMENT : R&D 2

REVISION : 2

RECEIVED			
<input checked="" type="checkbox"/> MASS PRODUCTION			
<input type="checkbox"/> PRELIMINARY			
<input type="checkbox"/> CUSTOMER DESIGN			
DEVICE NUMBER : DPT-552-055			
PAGE :8			
CUSTOMER	DESIGNER	CHECKER	APPROVER

1.1	Adapt the Data Sheet for the New Form	SEP,22,2000
REV	DESCRIPTION	RELEASE DATE

OFFICE: NO 25,Lane 76,Chung Yang Rd, Sec.3 Tucheng, Taipei 236, Taiwan, R.O.C.

TEL : 886-2-2267-2000,2266-9936 (22 Lines)

FAX : 886-2-2267-6189

<http://www.everlight.com>



Phototransistor

MODEL NO : PT5529B/L2/S3

■ Features :

- Wide angle of half sensitivity $\theta = \pm 65^\circ$
- High sensitivity
- Fast response time
- Pb free
- The product itself will remain within RoHS compliant version.

■ Description :

The PT5529B/L2/S3 is a high speed and high sensitivity dual phototransistor; molded in a flat side view plastic package. The device is spectrally matched with IR emitters.

■ Applications :

- Mouse
- Optoelectronic Switch
- Photo Interrupter

PART NO.	CHIP	LENS COLOR
	MATERIAL	
PT	Silicon	Black

Phototransistor

 MODEL NO : PT5529B/L2/S3

■ Package Dimension :

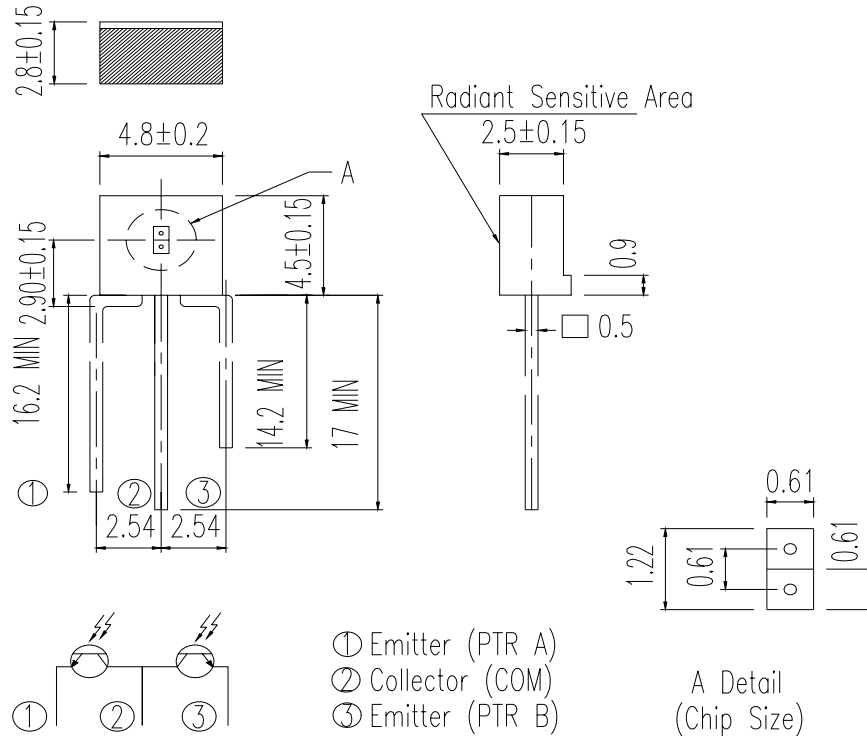

■ Notes :

1. All dimensions are in millimeter.
2. General tolerance: ± 0.1 mm
3. Lead spacing is measured where the lead emerge from the package.
4. Above specification may be changed without notice. EVERLIGHT will reserve authority on material change for above specification.
5. These specification sheets include materials protected under copyright of EVERLIGHT corporation . Please don't reproduce or cause anyone to reproduce them without EVERLIGHT's consent.
6. When using this product , please observe the absolute maximum ratings and the instructions for use outlined in these specification sheets. EVERIGHT assumes no responsibility for any damage resulting from use of the product which does not comply with the absolute maximum ratings and the instructions included in these specification sheets.



EVERLIGHT ELECTRONICS CO., LTD.

DEVICE NUMBER : DPT-552-055REV : 2

ECN : _____

PAGE : 3/8

Phototransistor

MODEL NO : PT5529B/L2/S3

■ Absolute Maximum Ratings at $T_A = 25^\circ\text{C}$

Parameter	Symbol	Rating	Unit
Collector Power Dissipation	P_D	75	mW
Collector-Emitter Voltage	V_{CEO}	30	V
Emitter-Collector Voltage	V_{ECO}	5	V
Collector Current	I_c	20	mA
Operating Temperature	T_{opr}	-25~+85	$^\circ\text{C}$
Storage Temperature	T_{stg}	-40~+85	$^\circ\text{C}$
Soldering Temperature (1/16 inch from body for 5 seconds)	T_{sol}	260	$^\circ\text{C}$

■ Electronic Optical Characteristics :

Parameter	Symbol	Min.	Typ.	Max.	Unit	Condition	
Collector Dark Current	I_{CEO}	-	-	100	nA	$V_{CE}=20\text{V}, E_e=0\text{mW}/\text{cm}^2$	
C-E Saturation Voltage	$V_{CE(Sat)}$	-	-	0.4	V	$I_c=0.5\text{mA}, E_e=10\text{mW}/\text{cm}^2$	
Collector Current	$I_{C(ON)}$	129 210	- -	944 910	μA	$V_{CE}=5\text{V}, E_e=0.555\text{mW}/\text{cm}^2$	
Wavelength of Peak Sensitivity	λ_p	-	860	-	nm	---	
Range of Spectral Bandwidth	$\lambda_{0.5}$	-	840..1200	-	nm	---	
Response Time	Rise Time	t_r	-	15	-	μSec	$V_{CE}=5\text{V}$ $I_c=1\text{mA}$ $R_L=1000\Omega$
	Fall Time	t_f	-	15	-	μSec	
Half sensitivity angle	$2\theta_{1/2}$	-	± 65	-	Deg	---	
Collector-Base Capacitance	C_{CB}	5.4	6.4	7.4	pF	$f=1\text{MHz}, V_{CB}=3\text{V}$	



Phototransistor

MODEL NO : PT5529B/L2/S3

Typical Electrical/Optical/Characteristics Curves For PT

Fig.1 Collector Power Dissipation vs. Ambient Temperature

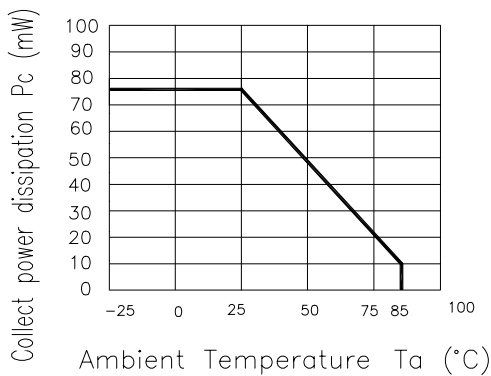

Fig.2 Collector Dark Current vs. Ambient Temperature

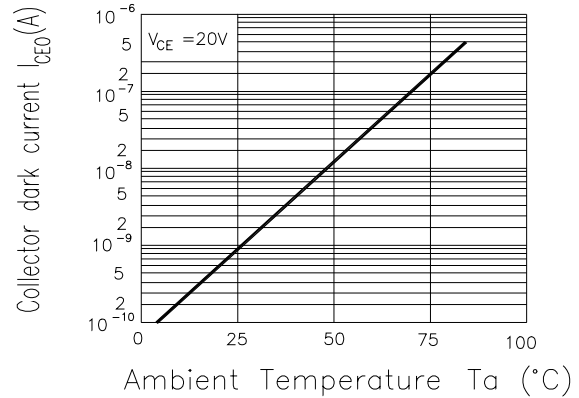

Fig. 3 Relative Collector Current vs. Ambient Temperature

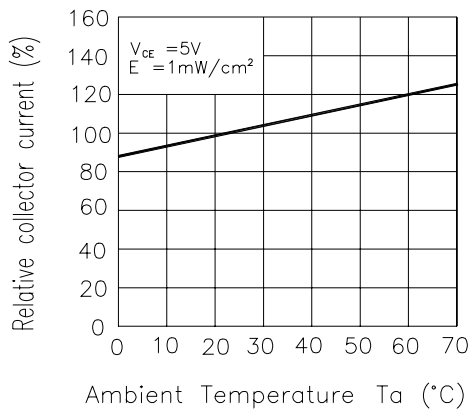

Fig.4 Collector Current vs. Irradiance

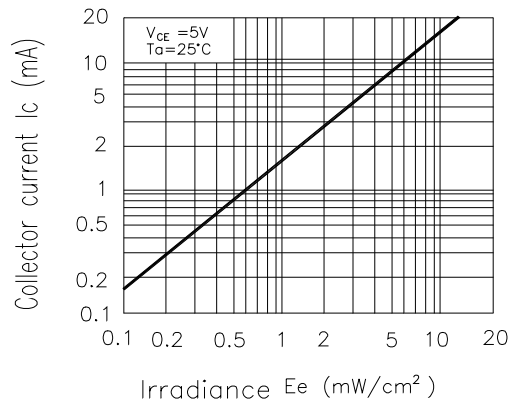

Fig.5 Spectral Sensitivity

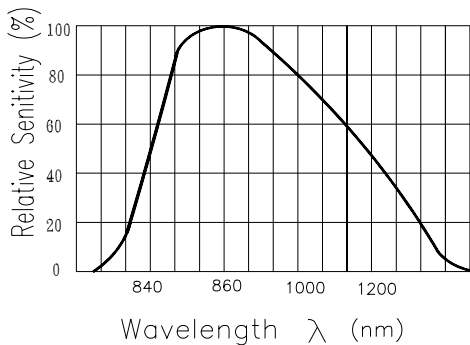
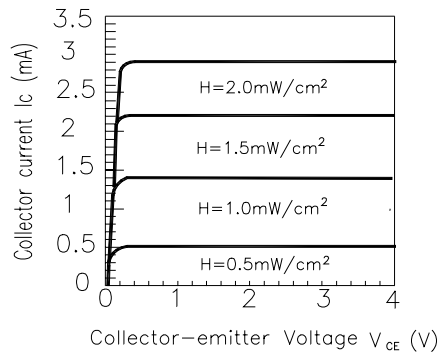

Fig.6 Collector Current vs. Collector-emitter Voltage





EVERLIGHT ELECTRONICS CO., LTD.

DEVICE NUMBER : DPT-552-055
ECN : _____

REV : 2
PAGE : 5/8

Phototransistor

MODEL NO : PT5529B/L2/S3

■ Reliability Test Item And Condition

The reliability of products shall be satisfied with items listed below.

Confidence level:90%

LTPD:10%

NO.	Item	Test Conditions	Test Hours/ Cycle	Sample Size	Failure Judgement Criteria	Ac/Re
1	Solder Heat	TEMP : 260°C ± 5 °C	5 sec	22 PCs	I _{c(on)} ≤ L×0.8 L :Lower specification limit	0/1
2	Temperature Cycle	H : +85°C 30 min ↑ 5 min ↓ L : -55°C 30 min	50 cycle	22 PCs		0/1
3	Thermal Shock	H : +100°C 5 min ↑ 10 sec ↓ L : -10°C 30 min	50 cycle	22 PCs		0/1
4	High Temperature Storage	TEMP. : +100°C	1000 hrs	22 PCs		0/1
5	Low Temperature Storage	TEMP. : -55°C	1000 hrs	22 PCs		0/1
6	DC Operating Life	V _{CE} =5V	1000 hrs	22 PCs		0/1
7	High Temperature / High Humidity	85°C / 85% R.H.	1000 hrs	22 PCs		0/1

Phototransistor

 MODEL NO : PT5529B/L2/S3

Test Method For On State Collector Current :

 Condition : $E_e=0.555\text{mW/cm}^2$, $V_{CE}=5\text{V}$

 Test Item : Collector Current [$I_{C(ON)}$]

 Unit : μA

The Light current testing method for PTR:

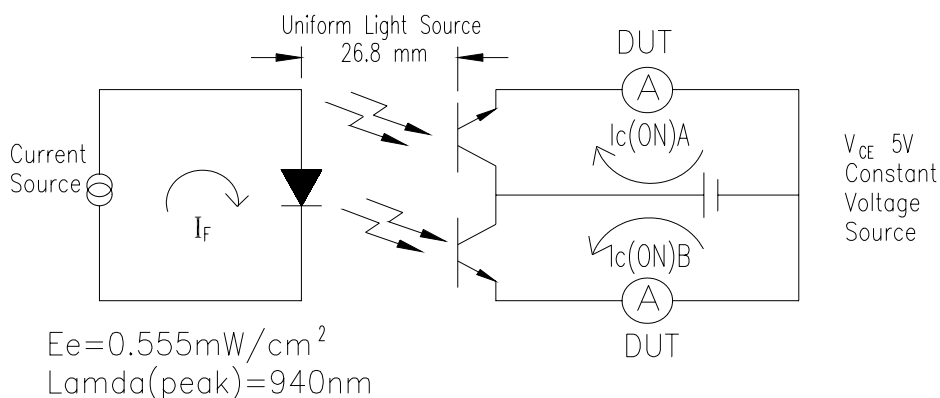

To Distinguish Intensity:

 Condition: $V_{CE}=5\text{V}$ $E_e=0.555\text{mW/cm}^2$

A Ranks

Color Code	Ranks	Symbol	Min	Typ	Max	Unit	Test Condition
Red	A1	$I_{C(ON)}$	129	---	226	μA	$E_e=0.555\text{mW/c m}^2$ $V_{CE}=5\text{V}$
Blue	A2	$I_{C(ON)}$	195	---	306	μA	$E_e=0.555\text{mW/c m}^2$ $V_{CE}=5\text{V}$
Yellow	A3	$I_{C(ON)}$	262	---	380	μA	$E_e=0.555\text{mW/c m}^2$ $V_{CE}=5\text{V}$
Silver	A4	$I_{C(ON)}$	330	---	461	μA	$E_e=0.555\text{mW/c m}^2$ $V_{CE}=5\text{V}$
Green	A5	$I_{C(ON)}$	398	---	544	μA	$E_e=0.555\text{mW/c m}^2$ $V_{CE}=5\text{V}$
Purple	A6	$I_{C(ON)}$	468	---	625	μA	$E_e=0.555\text{mW/c m}^2$ $V_{CE}=5\text{V}$
White	A7	$I_{C(ON)}$	536	---	703	μA	$E_e=0.555\text{mW/c m}^2$ $V_{CE}=5\text{V}$
Brown	A8	$I_{C(ON)}$	604	---	785	μA	$E_e=0.555\text{mW/c m}^2$ $V_{CE}=5\text{V}$
Orange	A9	$I_{C(ON)}$	673	---	862	μA	$E_e=0.555\text{mW/c m}^2$ $V_{CE}=5\text{V}$
Gold	A10	$I_{C(ON)}$	742	---	944	μA	$E_e=0.555\text{mW/c m}^2$ $V_{CE}=5\text{V}$

* $I_{C(ON)}=[I_{C(ON)A}+I_{C(ON)B}]/2$

DEVICE NUMBER : DPT-552-055REV : 2

ECN : _____

PAGE : 7/8

Phototransistor

MODEL NO : PT5529B/L2/S3

N Ranks

Color Code	Ranks	Symbol	Min	Typ	Max	Unit	Test Condition
Red	N1	$I_{C(ON)}$	220	---	340	μA	$E_e=0.555mW/cm^2$ $V_{CE}=5V$
Blue	N2	$I_{C(ON)}$	290	---	420	μA	$E_e=0.555mW/cm^2$ $V_{CE}=5V$
Yellow	N3	$I_{C(ON)}$	360	---	500	μA	$E_e=0.555mW/cm^2$ $V_{CE}=5V$
Silver	N4	$I_{C(ON)}$	430	---	580	μA	$E_e=0.555mW/cm^2$ $V_{CE}=5V$
Green	N5	$I_{C(ON)}$	500	---	660	μA	$E_e=0.555mW/cm^2$ $V_{CE}=5V$
Purple	N6	$I_{C(ON)}$	570	---	740	μA	$E_e=0.555mW/cm^2$ $V_{CE}=5V$
White	N7	$I_{C(ON)}$	640	---	820	μA	$E_e=0.555mW/cm^2$ $V_{CE}=5V$
Brown	N8	$I_{C(ON)}$	710	---	900	μA	$E_e=0.555mW/cm^2$ $V_{CE}=5V$

* $I_{C(ON)}=[I_{C(ON)A}+I_{C(ON)B}]/2$

* For the intensity test method, the output intensity is measured indirectly by a wide uniform light source(unfocused) calibrated to $0.555mW/cm^2$, 940nm radiant intensity at the PTR face. Details are shown in the above diagram. It's important that light intensity must be uniform across the face of the PTR under test. Maximum and minimum values must include all variation due to mechanical and electrical sorting and measurement error.

Phototransistor

 MODEL NO : PT5529B/L2/S3

■ Packing Specifications

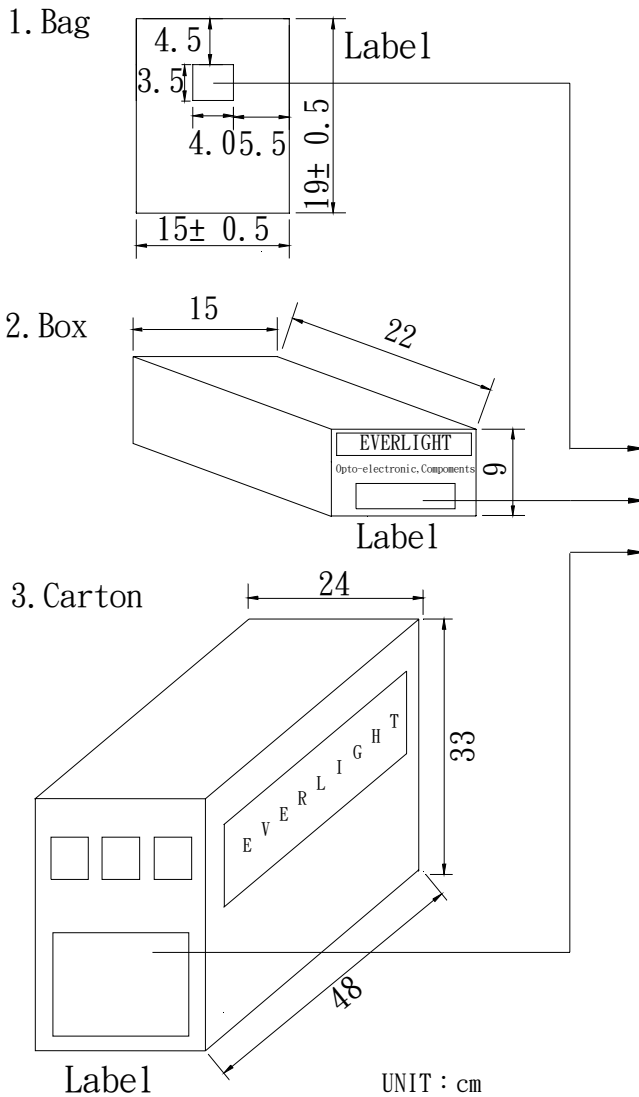

CPN : Customer's Production Number
 P/N : Production Number
 QTY : Packing Quantity
 CAT : Ranks
 HUE : Peak Wavelength
 REF : Reference
 LOT NO : Lot Number
 MADE IN TAIWAN : Production place

■ Packing Quantity Specification

1.500Pcs/1Bag , 10Bags/1Box

2.10Boxes/1Carton