



0.56" Tripple Digit Displays

MODEL NO : ELT-512HDB/P17 ECN : Page: 1/5

■ Features :

- Industrial standard size.
- Low power consumption.
- Categorized for luminous intensity.

■ Applications:

- Audio equipment
- Instrument panels
- Digital read out display

■ Description :

- The ELT-512 series is a large 14.22mm (0.56")high seven segment display design for viewing distances up to 7 meters.
- These displays provide excellent reliability in bright ambient light.
- These device is made with red segments and black surface.

PART NO	CHIP		C.C. or C.A.
	Material	Emitted Color	
ELT-512HDB/P17	GaP	Bright Red	C.A.

OFFICE : NO. 25,Lane 76,Sec.3, Chung Yang Rd., Tucheng 236, Taipei, Taiwan, R.O.C.
 TEL : 886-2-2267-2000,2267-9936
 FAX : 886-2-2267-6244,22676189,22676306
<http://www.everlight.com>



0.56" Tripple Digit Displays

Package Dimension:

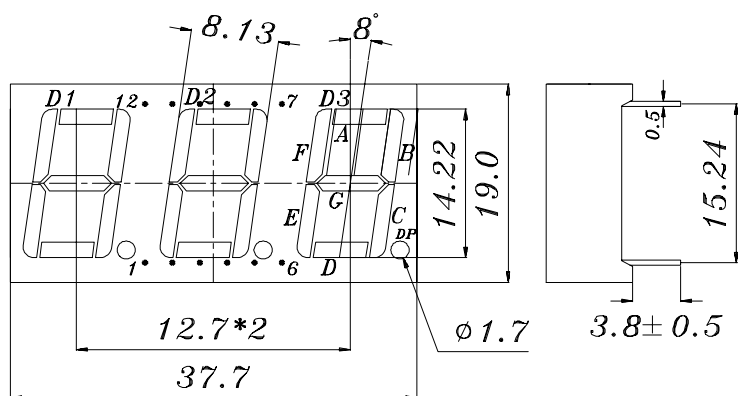

- COMMON ANODE
- 1 CATHODE E
 - 2 CATHODE D
 - 3 CATHODE DP
 - 4 CATHODE C
 - 5 CATHODE G
 - 6 NO CONNECT
 - 7 CATHODE B
 - 8 COMMON ANODE D3
 - 9 COMMON ANODE D2
 - 10 CATHODE F
 - 11 CATHODE A
 - 12 COMMON ANODE D1

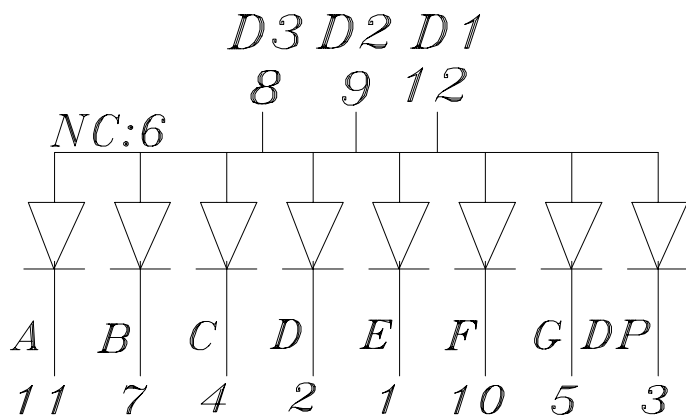
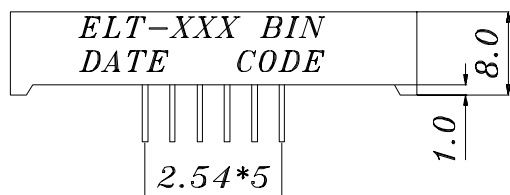

NOTES:

- 1.All dimensions are millimeters , tolerance is 0.25mm unless otherwise noted.
 - 2.Above specification may be changed without notice.
- Supplier will reserve authority on material change for above specification.



Device Number : DDT-512-048 REV: 1.0

0.56" Tripple Digit Displays

MODEL NO : ELT-512HDB/P17 ECN : _____ Page: 3/5

■ Absolute maximum ratings at Ta = 25°C :

Parameter	Symbol	Rating	Unit
Reverse Voltage	Vr	5	V
Forward Current	If	15	mA
Operating Temperature	Topr	-40 to +85	°C
Storage Temperature	Tstg	-40 to +100	°C
Soldering Temperature	Tsol	260 ± 5	°C
Power Dissipation	Pd	45	mW
Peak Forward Current(Duty 1/10 @ 1KHZ)	If(Peak)	50	mA

■ Electronic optical characteristics :

Parameter		Symbol	MIN.	TYP.	MAX.	Unit	Condition
Luminous Intensity	Per segment	Iv	0.28	0.5	----	mcd	If=10mA
	Per decimal point		0.10	0.20	----	mcd	If=10mA
Peak Wavelength		λ p	----	697	----	nm	If=10mA
Dominant Wavelength		λ d	----	650	----	nm	
Spectrum Rediation Bandwidth		Δ λ	----	90	----	nm	
Forward Voltage		Vf	1.5	2.0	2.6	V	
Reverse Current		Ir	----	----	10	μ A	Vr=5V



EVERLIGHT ELECTRONICS CO.,LTD.

Device Number : DDT-512-048 REV: 1.0

0.56" Tripple Digit Displays

MODEL NO : ELT-512HDB/P17 ECN : _____ Page: 4/5

Reliability test item and condition:					
NO	Item	Test Conditions	Test Hours/Cycle	Sample Size	Ac/Re
1	Solder Heat	TEMP : 260°C ± 5 °C	5 SEC	76 PCS	0/1
2	Temperature Cycle	H : +85°C 30min ∫ 5 min L : -55°C 30min	50 CYCLE	76 PCS	0/1
3	Thermal Shock	H : +100°C 5min ∫ 10 sec L : -10°C 5min	50 CYCLE	76 PCS	0/1
4	High Temperature Storage	TEMP : 100°C	1000 HRS	76 PCS	0/1
5	Low Temperature Storage	TEMP : -55°C	1000 HRS	76 PCS	0/1
6	DC Operating Life	If = 10 mA	1000 HRS	76 PCS	0/1
7	High Temperature / High Humidity	85°C/85% RH	1000 HRS	76 PCS	0/1



0.56" Tripple Digit Displays

