



# EVERLIGHT ELECTRONICS CO.,LTD.

Device Number : DDT-511-035 REV: 1.0

## 0.56" Tripple Digit Display

MODEL NO : ELT-511HWB/S235 ECN : \_\_\_\_\_ Page: 1/5

### ■ Features :

- Industrial standard size.
- Low power consumption.
- Categorized for luminous intensity.

### ■ Applications:

- Audio equipment
- Instrument panels
- Digital read out display

### ■ Descriptions :

- The ELT-511 series is a large 14.22mm (0.56")high seven segment display designed for viewing distances up to 7 meters.
- These displays provide excellent reliability in bright ambient light.
- These devices are made with white segments and black surface.

PART NO	Chip		C.C. or C.A.
	Material	Emitted Color	
ELT-511HWB/S235	GaP	Bright Red	C.C.

OFFICE : NO. 25,Lane 76,Sec.3, Chung Yang Rd., Tucheng 236, Taipei, Taiwan, R.O.C.

TEL : 886-2-2267-2000,2267-9936

FAX : 886-2-2267-6244,22676189,22676306

<http://www.everlight.com>



0.56" Tripple Digit Display

■ Package Dimensions:

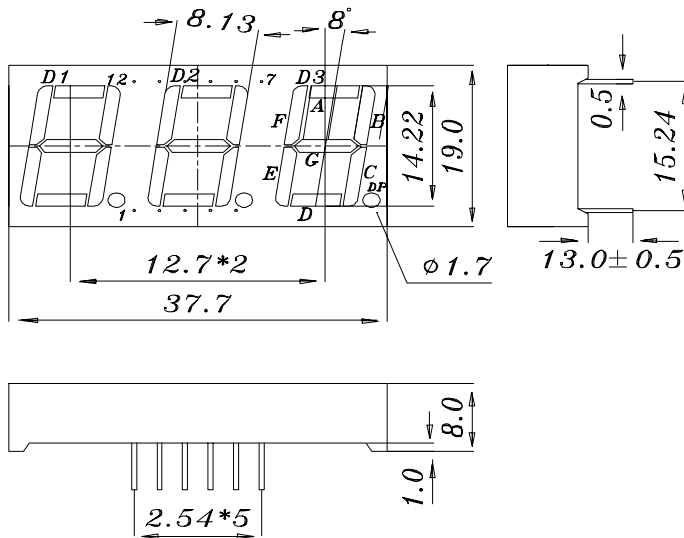

COMMON CATHODE

- 1 ANODE E
- 2 ANODE D
- 3 ANODE DP
- 4 ANODE C
- 5 ANODE G
- 6 NO PIN
- 7 ANODE B
- 8 COMMON CATHODE D3
- 9 COMMON CATHODE D2
- 10 ANODE F
- 11 ANODE A
- 12 COMMON CATHODE D1

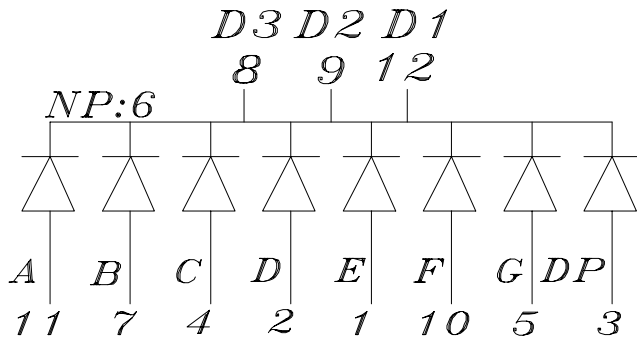

■ Notes:

- 1.All dimensions are in millimeters , tolerance is 0.25mm unless otherwise noted.
  - 2.Above specification may be changed without notice.
- Supplier will reserve authority on material change for above specification.



Device Number : DDT-511-035 REV: 1.0

0.56" Tripple Digit Display

MODEL NO : ELT-511HWB/S235 ECN :                      Page: 3/5

■ Absolute Maximum Ratings at Ta = 25°C :

Parameter	Symbol	Rating	Unit
Reverse Voltage	Vr	5	V
Forward Current	If	15	mA
Operating Temperature	Topr	-40 to +85	°C
Storage Temperature	Tstg	-40 to +100	°C
Soldering Temperature	Tsol	260 ± 5	°C
Soldering Temperature	Tsol	260 ± 5	°C
Power Dissipation	Pd	45	mW
Peak Forward Current(Duty 1/10 @ 1KHZ)	If(Peak)	50	mA

■ Electronic Optical Characteristics :

Parameter		Symbol	MIN.	TYP.	MAX.	Unit	Condition
Luminous Intensity	Per segment	Iv	0.18	0.40	----	mcd	If=10mA
	Per decimal point		0.05	0.10	----		
Peak Wavelength		λ p	----	697	----	nm	If=10mA
Dominant Wavelength		λ d	----	650	----	nm	If=10mA
Spectrum Radiation Bandwidth		Δ λ	----	90	----	nm	If=10mA
Forward Voltage		Vf	1.5	2.0	2.4	V	If=10mA
Reverse Current		Ir	----	----	10	μ A	Vr=5V



# EVERLIGHT ELECTRONICS CO.,LTD.

Device Number : DDT-511-035 REV: 1.0

0.56" Tripple Digit Display

MODEL NO : ELT-511HWB/S235 ECN : \_\_\_\_\_ Page: 4/5

■ Reliability test items and conditions:					
NO	Item	Test Conditions	Test Hours/Cycle	Sample Size	Ac/Re
1	Solder Heat	TEMP : 260°C ± 5 °C	5 SEC	76 PCS	0/1
2	Temperature Cycle	H : +85°C 30min ∫ 5 min L : -55°C 30min	50 CYCLE	76 PCS	0/1
3	Thermal Shock	H : +100°C 5min ∫ 10 sec L : -10°C 5min	50 CYCLE	76 PCS	0/1
4	High Temperature Storage	TEMP : 100°C	1000 HRS	76 PCS	0/1
5	Low Temperature Storage	TEMP : -55°C	1000 HRS	76 PCS	0/1
6	DC Operating Life	If = 10 mA	1000 HRS	76 PCS	0/1
7	High Temperature / High Humidity	85°C/85% RH	1000 HRS	76 PCS	0/1



Device Number : DDT-511-035 REV: 1.0

0.56" Tripple Digit Display

MODEL NO: ELT-511HWB/S235 ECN :            Page: 5/5

■ Typical Electro-Optical Characteristic Curves:

