



# EVERLIGHT ELECTRONICS CO.,LTD.

Device Number : DDD-526-045 REV: 1.0

## 0.54" Dual Digit Alphanumeric Displays

MODEL NO : ELD-526SYGWA/S530-E1 ECN : \_\_\_\_\_ Page: 1/5

### ■ Features :

- Industrial standard size.
- Low power consumption.
- Categorized for luminous intensity.

### ■ Description :

- The ELD-526 series is a large 13.6mm (0.54")high seven segment display design for viewing distances up to 7 meters.
- These displays provide excellent reliability in bright ambient light.
- These device is made with white segments and gray surface.

### ■ Applications:

- Audio equipment
- Instrument panels
- Digital read out display

PART NO	CHIP		C.C. or C.A.
	Material	Emitted Color	
ELD-526SYGWA/S530-E1	AlGaInP	Super Yellow Green	C.A.

OFFICE : NO. 25,Lane 76,Sec.3, Chung Yang Rd., Tucheng 236, Taipei, Taiwan, R.O.C.

TEL : 886-2-2267-2000,2267-9936

FAX : 886-2-2267-6244,22676189,22676306

<http://www.everlight.com>



## 0.54" Dual Digit Alphanumeric Displays

### Package Dimension:

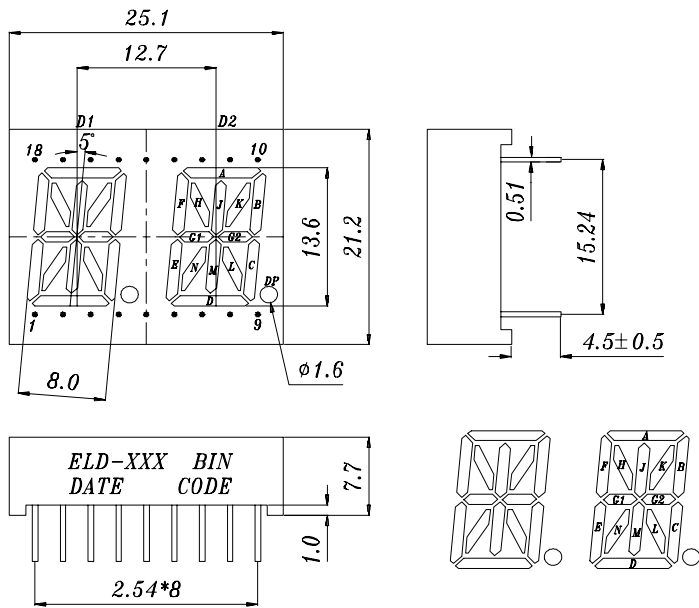

- COMMON ANODE**
- 1 CATHODE E
  - 2 CATHODE N
  - 3 NO CONNECT
  - 4 CATHODE M
  - 5 CATHODE L
  - 6 CATHODE G2
  - 7 CATHODE D
  - 8 CATHODE DP
  - 9 CATHODE C
  - 10 CATHODE B
  - 11 COMMON ANODE DIG.2
  - 12 CATHODE A
  - 13 CATHODE G1
  - 14 CATHODE K
  - 15 CATHODE J
  - 16 COMMON ANODE DIG.1
  - 17 CATHODE H
  - 18 CATHODE F

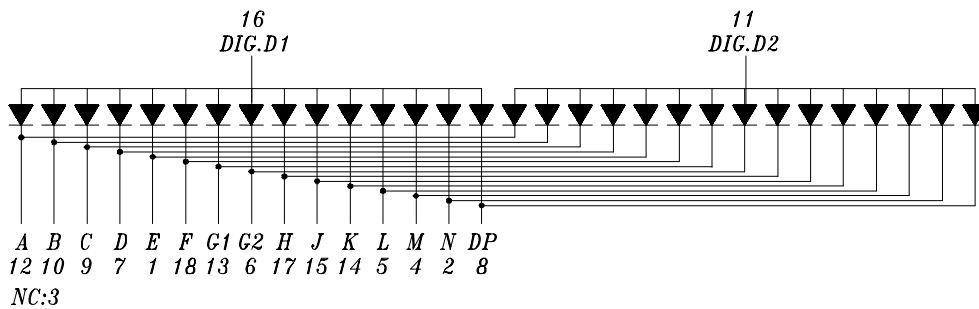

### NOTES:

1. All dimensions are millimeters, tolerance is 0.25mm unless otherwise noted.
  2. Above specification may be changed without notice.
- Supplier will reserve authority on material change for above specification.



## 0.54" Dual Digit Alphanumeric Displays

### ■ Absolute maximum ratings at Ta = 25°C :

Parameter	Symbol	Rating	Unit
Reverse Voltage	Vr	5	V
Forward Current	If	25	mA
Operating Temperature	Topr	-40 to +85	°C
Storage Temperature	Tstg	-40 to +100	°C
Soldering Temperature	Tsol	260 ± 5	°C
Electrostatic Discharge	ESD	2000	V
Power Dissipation	Pd	60	mW
Peak Forward Current(Duty 1/10 @ 1KHZ)	If(Peak)	160	mA

### ■ Electronic optical characteristics :

Parameter		Symbol	MIN.	TYP.	MAX.	Unit	Condition
Luminous Intensity	Per	Iv	0.28	0.8	----	mcd	If=2mA
	segment		2.0	5.3	----		
	Per		0.07	0.45	----	mcd	If=2mA
	decimal point		0.75	2.80	----		
Peak Wavelength		$\lambda p$	----	575	----	nm	If=20mA
Dominant Wavelength		$\lambda d$	----	573	----	nm	If=20mA
Spectrum Radiation Bandwidth		$\Delta \lambda$	----	20	----	nm	If=20mA
Forward Voltage		Vf	----	2.0	2.4	V	If=20mA
Reverse Current		Ir	----	----	10	$\mu A$	Vr=5V



# EVERLIGHT ELECTRONICS CO.,LTD.

Device Number : DDD-526-045 REV: 1.0

0.54" Dual Digit Alphanumeric Displays

MODEL NO : ELD-526SYGWA/S530-E1 ECN : \_\_\_\_\_ Page: 4/5

■ Reliability test item and condition:

NO	Item	Test Conditions	Test Hours/Cycle	Sample Size	Ac/Re
1	Solder Heat	TEMP : 260°C ± 5 °C	5 SEC	76 PCS	0/1
2	Temperature Cycle	H : +85°C 30min ∫ 5 min L : -55°C 30min	50 CYCLE	76 PCS	0/1
3	Thermal Shock	H : +100°C 5min ∫ 10 sec L : -10°C 5min	50 CYCLE	76 PCS	0/1
4	High Temperature Storage	TEMP : 100°C	1000 HRS	76 PCS	0/1
5	Low Temperature Storage	TEMP : -55°C	1000 HRS	76 PCS	0/1
6	DC Operating Life	If = 10 mA	1000 HRS	76 PCS	0/1
7	High Temperature / High Humidity	85°C/85% RH	1000 HRS	76 PCS	0/1

--	--	--	--	--	--



0.54" Dual Digit Alphanumeric Displays

