



EVERLIGHT ELECTRONICS CO.,LTD.

Device Number : DDD-525-002 REV: 1.1

0.54" Dual Digit Alphanumeric Displays

MODEL NO : ELD-525EWA ECN : Page: 1/5

■ Features :

- Industrial standard size.
- Low power consumption.
- Categorized for luminous intensity.

■ Applications:

- Audio equipment
- Instrument panels
- Digital read out display

■ Descriptions :

- The ELD-526 series is a large 13.6mm (0.54")high seven segment display design for viewing distances up to 7 meters.
- These displays provide excellent reliability in bright ambient light.
- These device is made with white segments and gray surface.

| PART NO | CHIP | | C.C. or C.A. |
|------------|-----------|---------------|--------------|
| | Material | Emitted Color | |
| ELD-525EWA | GaAsP/GaP | Orange | C.C. |

OFFICE : NO. 25,Lane 76,Sec.3, Chung Yang Rd., Tucheng 236, Taipei, Taiwan, R.O.C.

TEL : 886-2-2267-2000,2267-9936

FAX : 886-2-2267-6244,22676189,22676306

<http://www.everlight.com>



0.54" Dual Digit Alphanumeric Displays

Package Dimensions:

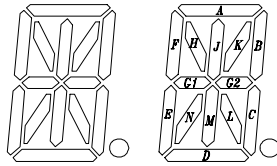
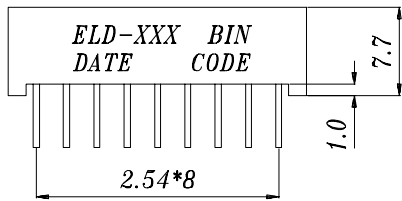
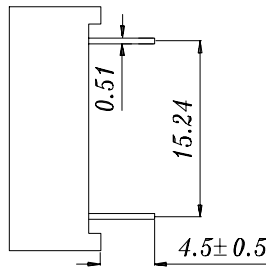
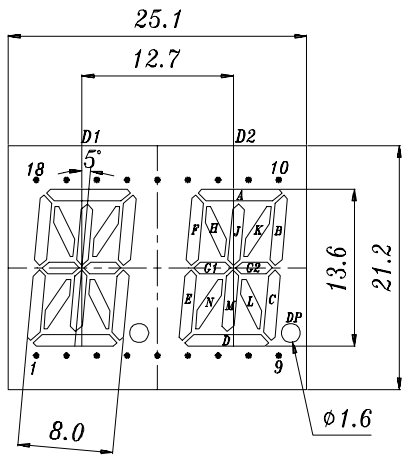

- COMMON CATHODE**
- 1 ANODE E
 - 2 ANODE N
 - 3 NO CONNECT
 - 4 ANODE M
 - 5 ANODE L
 - 6 ANODE G2
 - 7 ANODE D
 - 8 ANODE DP
 - 9 ANODE C
 - 10 ANODE B
 - 11 COMMON CATHODE DIG.2
 - 12 ANODE A
 - 13 ANODE G1
 - 14 ANODE K
 - 15 ANODE J
 - 16 COMMON CATHODE DIG.1
 - 17 ANODE H
 - 18 ANODE F

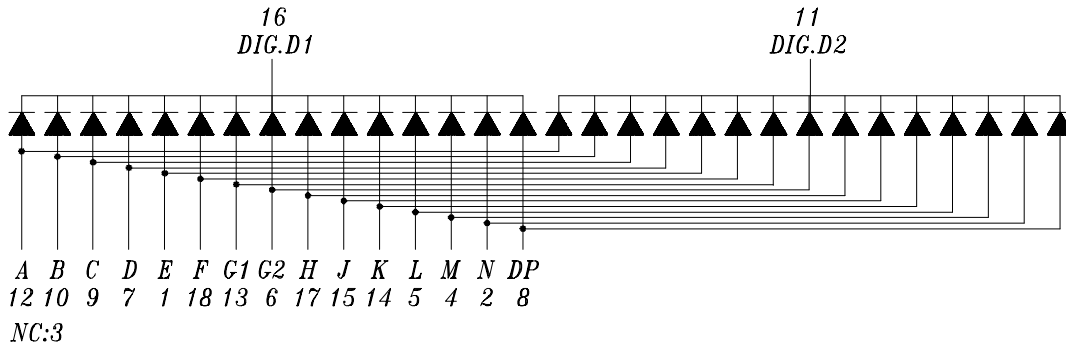

NOTES:

- 1.All dimensions are in millimeters , tolerance is 0.25mm unless otherwise noted.
 - 2.Above specification may be changed without notice.
- Supplier will reserve authority on material change for above specification.



Device Number : DDD-525-002 REV: 1.1

0.54" Dual Digit Alphanumeric Displays

MODEL NO : ELD-525EWA ECN : _____ Page: 3/5

■ Absolute maximum ratings at Ta = 25°C :

| Parameter | Symbol | Rating | Unit |
|--|----------|-------------|------|
| Reverse Voltage | Vr | 5 | V |
| Forward Current | If | 30 | mA |
| Operating Temperature | Topr | -40 to +85 | °C |
| Storage Temperature | Tstg | -40 to +100 | °C |
| Soldering Temperature | Tsol | 260 ± 5 | °C |
| Power Dissipation | Pd | 100 | mW |
| Peak Forward Current(Duty 1/10 @ 1KHZ) | If(Peak) | 160 | mA |

■ Electronic optical characteristics :

| Parameter | | Symbol | MIN. | TYP. | MAX. | Unit | Condition |
|------------------------------|-------------------|------------------|------|------|------|---------|-----------|
| Luminous Intensity | Per segment | Iv | 0.75 | 1.50 | ---- | mcd | If=10mA |
| | Per decimal point | | 0.25 | 0.50 | ---- | mcd | If=10mA |
| Peak Wavelength | | λp | ---- | 635 | ---- | nm | If=20mA |
| Dominant Wavelength | | λd | ---- | 625 | ---- | nm | If=20mA |
| Spectrum Radiation Bandwidth | | $\Delta \lambda$ | ---- | 45 | ---- | nm | If=20mA |
| Forward Voltage | | Vf | 1.7 | 2.0 | 2.4 | V | If=20mA |
| Reverse Current | | Ir | ---- | ---- | 10 | μA | Vr=5V |



EVERLIGHT ELECTRONICS CO.,LTD.

Device Number : DDD-525-002 REV: 1.1

0.54" Dual Digit Alphanumeric Displays

MODEL NO : ELD-525EWA ECN : _____ Page: 4/5

■ Reliability test item and condition:

| NO | Item | Test Conditions | Test Hours/Cycle | Sample Size | Ac/Re |
|----|----------------------------------|---|------------------|-------------|-------|
| 1 | Solder Heat | TEMP : 260°C ± 5 °C | 5 SEC | 76 PCS | 0/1 |
| 2 | Temperature Cycle | H : +85°C 30min ∫ 5 min L : -55°C 30min | 50 CYCLE | 76 PCS | 0/1 |
| 3 | Thermal Shock | H : +100°C 5min ∫ 10 sec L : -10°C 5min | 50 CYCLE | 76 PCS | 0/1 |
| 4 | High Temperature Storage | TEMP : 100°C | 1000 HRS | 76 PCS | 0/1 |
| 5 | Low Temperature Storage | TEMP : -55°C | 1000 HRS | 76 PCS | 0/1 |
| 6 | DC Operating Life | If = 10 mA | 1000 HRS | 76 PCS | 0/1 |
| 7 | High Temperature / High Humidity | 85°C / 85% RH | 1000 HRS | 76 PCS | 0/1 |



EVERLIGHT ELECTRONICS CO.,LTD.

Device Number : DDD-525-002 REV: 1.1

0.54" Dual Digit Alphanumeric Displays

MODEL NO: ELD-525EWA ECN : Page: 5/5

■ Typical Electro-Optical Characteristic Curves:

E

