



EVERLIGHT ELECTRONICS CO.,LTD.

Device Number : DDD-511-001 REV: 1.1

0.56" Dual Digit Displays

MODEL NO : ELD-511IDB ECN : _____ Page: 1/5

■ Features :

- Industrial standard size.
- Low power consumption.
- Categorized for luminous intensity.

■ Applications:

- Audio equipment
- Instrument panels
- Digital read out display

■ Descriptions :

- The ELD-511 series is a large 14.22mm (0.56")high seven segment display design for viewing distances up to 7 meters.
- These displays provide excellent reliability in bright ambient light.
- These device is made with red segments and black surface.

PART NO	CHIP		C.C. or C.A.
	Material	Emitted Color	
ELD-511IDB	GaAsP/GaP	Hi-Eff Red	C.C.

OFFICE : NO. 25,Lane 76,Sec.3, Chung Yang Rd., Tucheng 236, Taipei, Taiwan, R.O.C.
 TEL : 886-2-2267-2000,2267-9936
 FAX : 886-2-2267-6244,22676189,22676306
<http://www.everlight.com>



0.56" Dual Digit Displays

MODEL NO : ELD-511IDB ECN : _____ Page: 2/5

Package Dimensions:

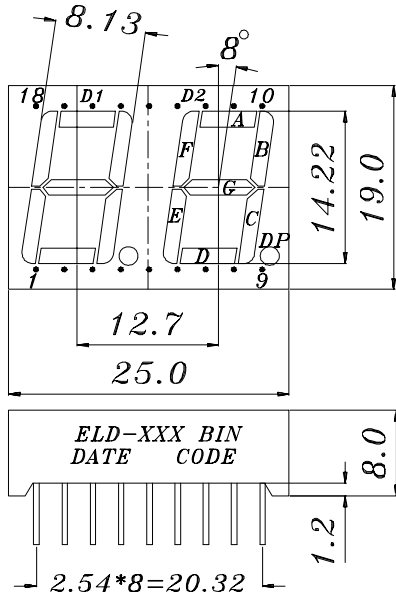

COMMON CATHODE

- 1 ANODE E D1
- 2 ANODE D D1
- 3 ANODE C D1
- 4 ANODE DP D1
- 5 ANODE E D2
- 6 ANODE D D2
- 7 ANODE G D2
- 8 ANODE C D2
- 9 ANODE DP D2
- 10 ANODE B D2
- 11 ANODE A D2
- 12 ANODE F D2
- 13 COMMON CATHODE D2
- 14 COMMON CATHODE D1
- 15 ANODE B D1
- 16 ANODE A D1
- 17 ANODE G D1
- 18 ANODE F D1

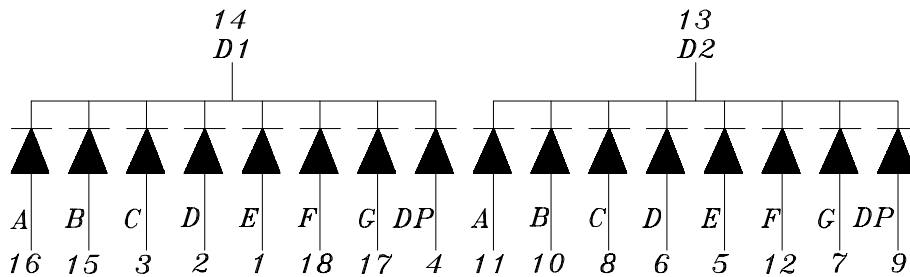

NOTES:

1.All dimensions are in millimeters , tolerance is 0.25mm unless otherwise noted.

2.Above specification may be changed without notice.

Supplier will reserve authority on material change for above specification.



Device Number : DDD-511-001 REV: 1.1

0.56" Dual Digit Displays

MODEL NO : ELD-511IDB ECN : Page: 3/5

■ Absolute maximum ratings at Ta = 25°C :

Parameter	Symbol	Rating	Unit
Reverse Voltage	Vr	5	V
Forward Current	If	30	mA
Operating Temperature	Topr	-40 to +85	°C
Storage Temperature	Tstg	-40 to +100	°C
Soldering Temperature	Tsol	260 ± 5	°C
Power Dissipation	Pd	100	mW
Peak Forward Current(Duty 1/10 @ 1KHZ)	If(Peak)	160	mA

■ Electronic optical characteristics :

Parameter		Symbol	MIN.	TYP.	MAX.	Unit	Condition
Luminous Intensity	Per segment	Iv	1.4	2.0	----	mcd	If=10mA
	Per decimal point		0.45	1.05	----		
Peak Wavelength		λp	----	635	----	nm	If=20mA
Dominant Wavelength		λd	----	625	----	nm	If=20mA
Spectrum Radiation Bandwidth		$\Delta \lambda$	----	45	----	nm	If=20mA
Forward Voltage		Vf	1.7	2.0	2.4	V	If=20mA
Reverse Current		Ir	----	----	10	μA	Vr=5V



EVERLIGHT ELECTRONICS CO.,LTD.

Device Number : DDD-511-001 REV: 1.1

0.56" Dual Digit Displays

MODEL NO : ELD-511IDB ECN : Page: 4/5

■ Reliability test item and condition:

NO	Item	Test Conditions	Test Hours/Cycle	Sample Size	Ac/Re
1	Solder Heat	TEMP : 260°C ± 5 °C	5 SEC	76 PCS	0/1
2	Temperature Cycle	H : +85°C 30min ∫ 5 min L : -55°C 30min	50 CYCLE	76 PCS	0/1
3	Thermal Shock	H : +100°C 5min ∫ 10 sec L : -10°C 5min	50 CYCLE	76 PCS	0/1
4	High Temperature Storage	TEMP : 100°C	1000 HRS	76 PCS	0/1
5	Low Temperature Storage	TEMP : -55°C	1000 HRS	76 PCS	0/1
6	DC Operating Life	If = 10 mA	1000 HRS	76 PCS	0/1
7	High Temperature / High Humidity	85°C/85% RH	1000 HRS	76 PCS	0/1

--	--	--	--	--	--

