



# EVERLIGHT ELECTRONICS CO.,LTD.

Device Number : CDDD-511-013 REV: 1

0.56" Dual Digit Displays

PART NO. : ELD-511EWB ECN : \_\_\_\_\_ Page: 1/5

■ Features :

- Industrial standard size.
- Low power consumption.
- Categorized for luminous intensity.

■ Applications:

- Audio equipment
- Instrument panels
- Digital read out display

■ Descriptions :

- The ELD-511 series is a large 14.22 mm (0.56")high seven segment display designed for viewing distances up to 7 meters.
- These displays provide excellent reliability in bright ambient light.
- These devices are made with white segments and black surface.

PART NO.	Chip	
	Material	Emitted Color
ELD-511EWB	GaAsP/GaP	Orange

OFFICE : NO. 25,Lane 76,Sec.3, Chung Yang Rd., Tucheng 236, Taipei, Taiwan, R.O.C.

TEL : 886-2-2267-2000,2267-9936

FAX : 886-2-2267-6244,22676189,22676306

<http://www.everlight.com>



## 0.56" Dual Digit Displays

### Package Dimensions:

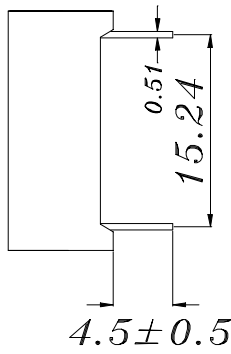
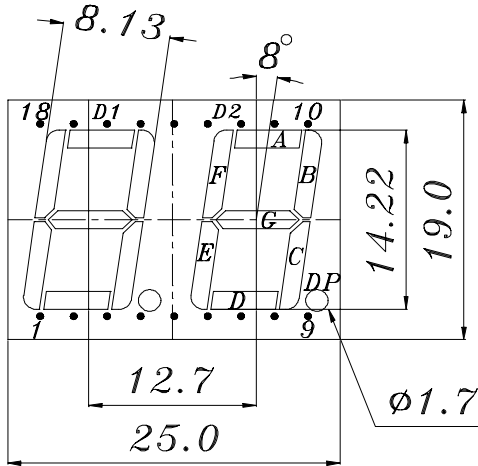

- COMMON CATHODE**
- 1 ANODE E D1
  - 2 ANODE D D1
  - 3 ANODE C D1
  - 4 ANODE DP D1
  - 5 ANODE E D2
  - 6 ANODE D D2
  - 7 ANODE G D2
  - 8 ANODE C D2
  - 9 ANODE DP D2
  - 10 ANODE B D2
  - 11 ANODE A D2
  - 12 ANODE F D2
  - 13 COMMON CATHODE D2
  - 14 COMMON CATHODE D1
  - 15 ANODE B D1
  - 16 ANODE A D1
  - 17 ANODE G D1
  - 18 ANODE F D1

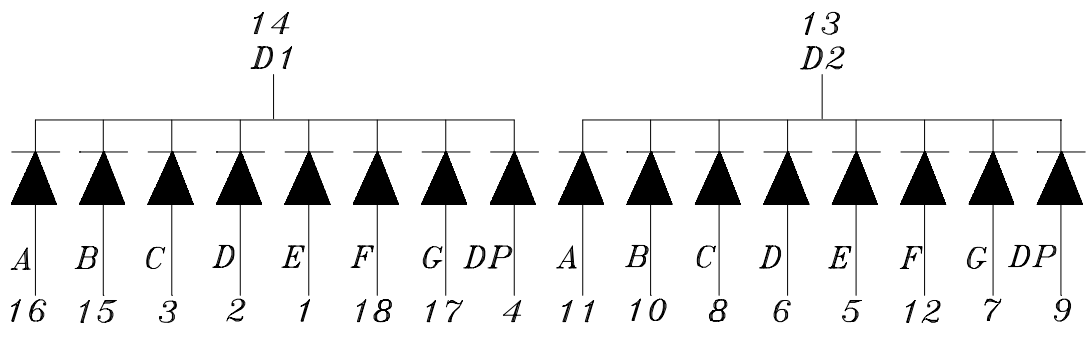
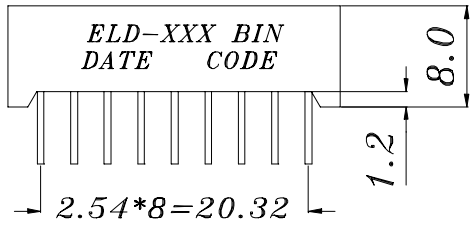

### Notes:

1. All dimensions are in millimeters, tolerance is 0.25mm unless otherwise noted.
  2. Above specification may be changed without notice.
- Supplier will reserve authority on material change for above specification.



# EVERLIGHT ELECTRONICS CO.,LTD.

Device Number : CDDD-511-013 REV: 1

0.56" Dual Digit Displays

PART NO. : ELD-511EWB ECN :          Page: 3/5

## ■ Absolute maximum ratings at Ta = 25°C :

Parameter	Symbol	Rating	Unit
Reverse Voltage	VR	5	V
Forward Current	IF	30	mA
Operating Temperature	Topr	-40 to +85	°C
Storage Temperature	Tstg	-40 to +100	°C
Soldering Temperature	Tsol	260 ± 5	°C
Power Dissipation	Pd	100	mW
Peak Forward Current(Duty 1/10 @ 1KHZ)	IF(Peak)	160	mA

## ■ Electronic optical characteristics :

Parameter		Symbol	Min.	Typ.	Max.	Unit	Condition
Luminous Intensity	Per segment	Iv	1.40	2.0	----	mcd	IF=10mA
	Per decimal point		0.3	0.6	----		
Peak Wavelength		$\lambda p$	----	635	----	nm	IF=20mA
Dominant Wavelength		$\lambda d$	----	625	----	nm	IF=20mA
Spectrum Radiation	Bandwidth	$\Delta \lambda$	----	45	----	nm	IF=20mA
Forward Voltage		VF	1.7	2.0	2.4	V	IF=20mA
Reverse Current		IR	----	----	10	$\mu A$	VR=5V



# EVERLIGHT ELECTRONICS CO.,LTD.

Device Number : CDDD-511-013

REV: 1

0.56" Dual Digit Displays

PART NO. : ELD-511EWB

ECN :

Page: 4/5

## Typical Electro-Optical Characteristic Curves:

CHIP Material:GaAsP/GaP  
Emitted Color:Hi-Eff Red/Orange

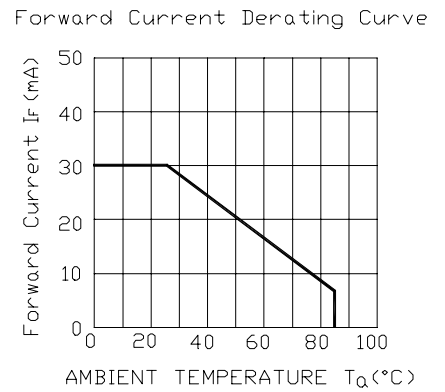
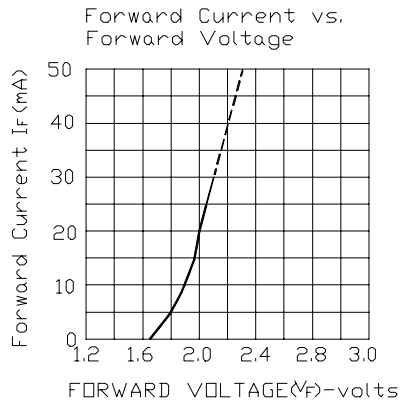
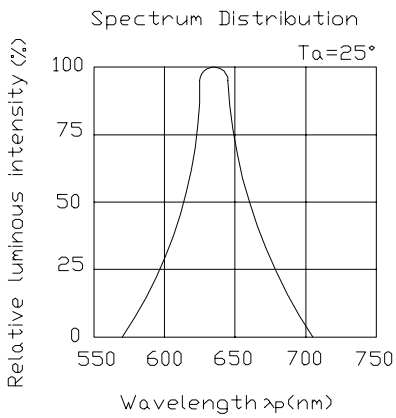



# EVERLIGHT ELECTRONICS CO.,LTD.

Device Number : CDDD-511-013 REV: 1

0.56" Dual Digit Displays

PART NO. : ELD-511EWB ECN :                      Page: 5/5

■ Reliability test items and conditions:

NO	Item	Test Conditions	Test Hours/Cycle	Sample Size	Ac/Re
1	Solder Heat	TEMP : 260°C ± 5 °C	5 SEC	76 PCS	0/1
2	Temperature Cycle	H : +85°C 30min ∫ 5 min L : -55°C 30min	50 CYCLE	76 PCS	0/1
3	Thermal Shock	H : +100°C 5min ∫ 10 sec L : -10°C 5min	50 CYCLE	76 PCS	0/1
4	High Temperature Storage	TEMP : 100°C	1000 HRS	76 PCS	0/1
5	Low Temperature Storage	TEMP : -55°C	1000 HRS	76 PCS	0/1
6	DC Operating Life	IF = 10 mA	1000 HRS	76 PCS	0/1
7	High Temperature / High Humidity	85°C /85% RH	1000 HRS	76 PCS	0/1

--	--	--	--	--	--