

Technical Data Sheet

1.9mm Round Subminiature Lead LEDs

95-21USRC/S400-XX/XXX

Features

- Package in 12mm tape on 7" diameter reels.
- Compatible with automatic placement equipment.
- EIA Std. package.
- Mono-color type.

Descriptions

- The 95-21 SMD taping is much smaller than leaded components .Thus enable smaller board size. Higher packing density. Reduced storage space and finally smaller equipment to be obtained.
- Besides , light weight makes them ideal for miniature applications.
- Further more by automation assembly machines the accuracy is anticipated.

Applications

- Small indicator for indoor applications.
- Flat backlight for LCD, switches and symbols.
- Indicator and backlight in office equipment.
- Indicator and backlight for battery driven equipment.
- Indicator and backlight for audio and video equipment.
- Automotive : backlighting in dashboards and switches.
- Telecommunication : indicator and backlighting in telephone and fax.



Device Selection Guide

Chip		Lens Color
Material	Emitted Color	
AlGaN _P	Super Red	Water Clear

95-21USRC/S400-XX/XXX

Package Outline Dimensions

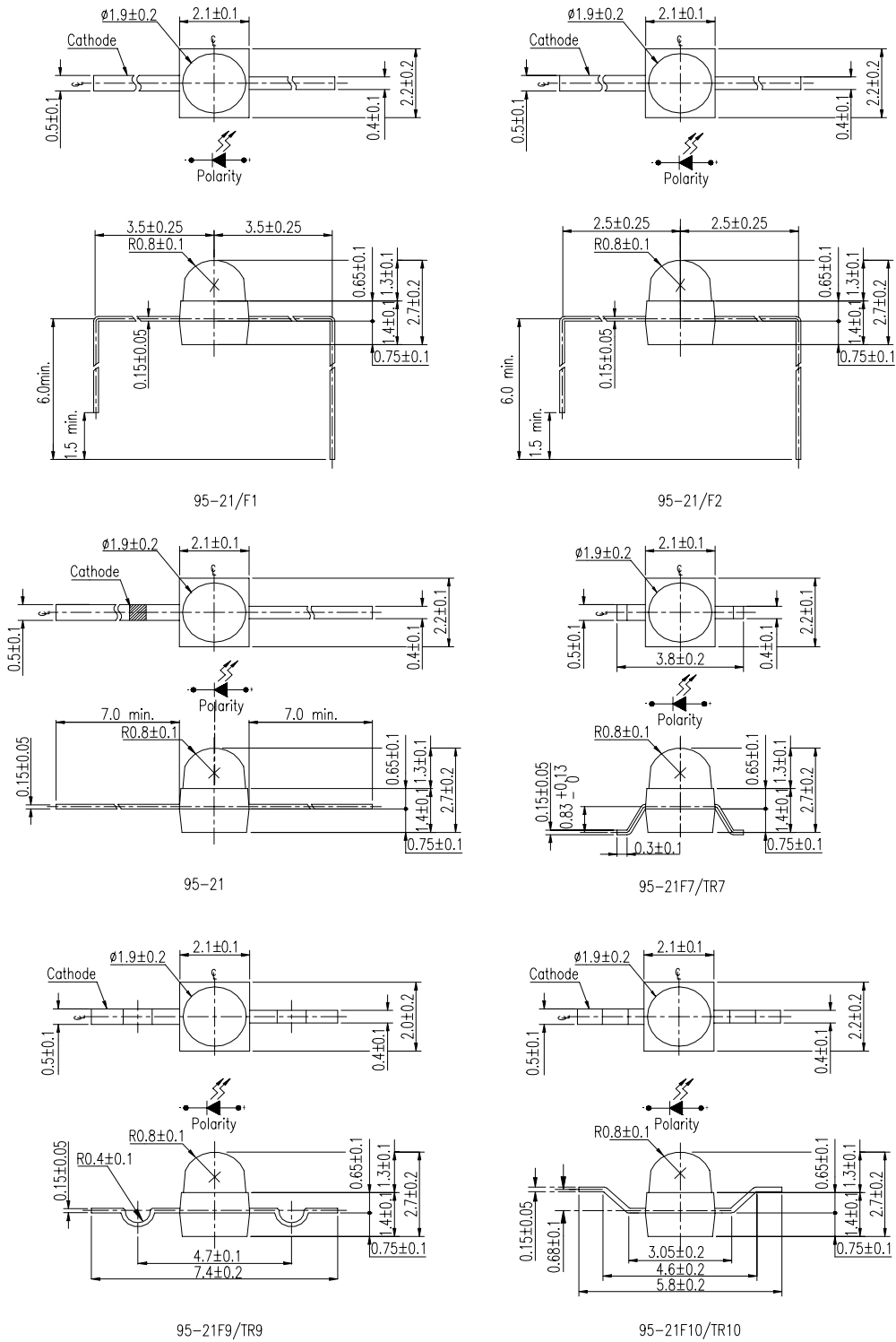

Note: Unit=mm

Absolute Maximum Ratings (Ta=25°C)

Parameter	Symbol	Rating	Unit
Reverse Voltage	V _R	5	V
Forward Current	I _F	50	mA
Operating Temperature	Topr	-40 ~ +85	°C
Storage Temperature	Tstg	-40 ~ +100	°C
Soldering Temperature	Tsol	260 for 5 seconds	°C
Electrostatic Discharge	ESD	2000	V
Power Dissipation	Pd	120	mW
Peak Forward Current(Duty 1/10 @ 1KHz)	I _F	200	mA

Electro-Optical Characteristics (Ta=25°C)

Parameter	Symbol	Rank	Min.	Typ.	Max.	Unit	Condition
Luminous Intensity	I _v	A2	176	371	----	mcd	I _F =20mA
		A3	315	503	----		
		A4	378	635	----		
		A5	503	819	----		
		A6	630	1000	----		
Viewing Angle	2θ 1/2	----	----	25	----	deg	
Peak Wavelength	λ _p	----	----	639	----	nm	
Dominant Wavelength	λ _d	----	----	631	----	nm	
Spectrum Radiation	△λ	----	----	20	----	nm	
Forward Voltage	V _F	----	----	2.0	2.4	V	
Reverse Current	I _R	----	----	----	10	μA	V _R =5V

95-21USRC/S400-XX/XXX

Reel & Carrier Tape Dimensions

Loaded quantity per reel 1000 PCS/reel

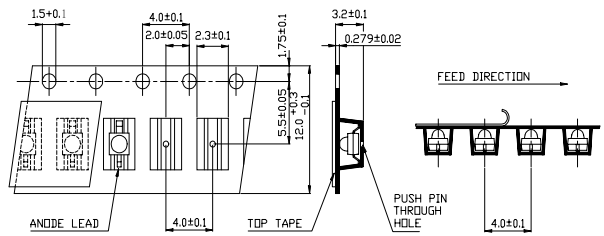
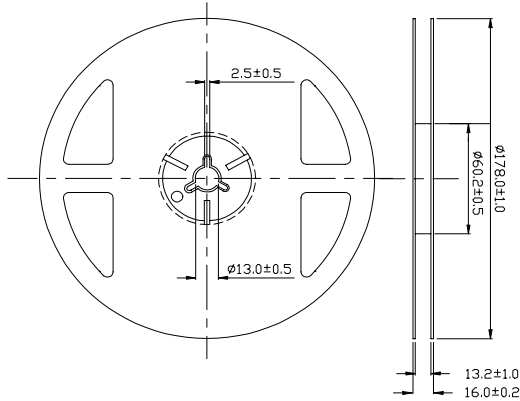

TR7

Material Descriptions

95-21 USRC /S400- XX / XXX

- 1
- 2
- 3
- 4

1.production part no.:95-21

2.chip part no.& epoxy color

AlGaInP =USR...

C = water clear

3.chip size & chip rank

chip size:S400(12mil)

chip rank: A2~A6

4.packing method:

(1)NONE,F1,F2, F7,F9,F10 : Bulk

(2) TR7,TR9,TR10 : Taping

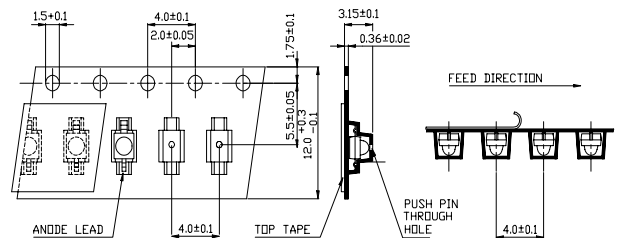

TR9

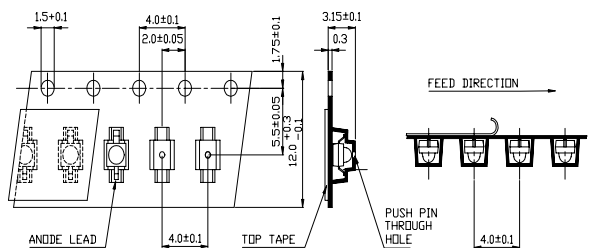

TR10

95-21USRC/S400-XX/XXX

Typical Electro-Optical Characteristics Curves

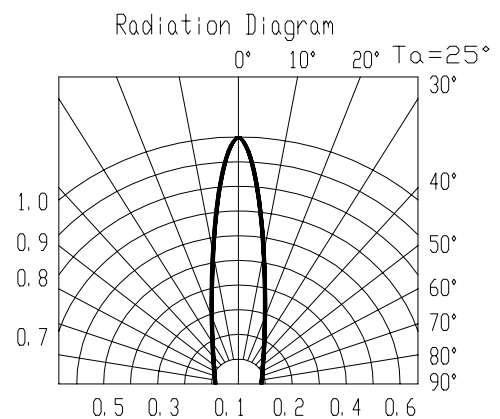
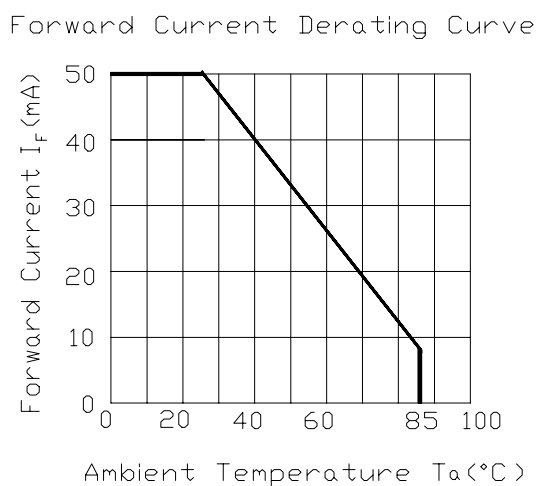
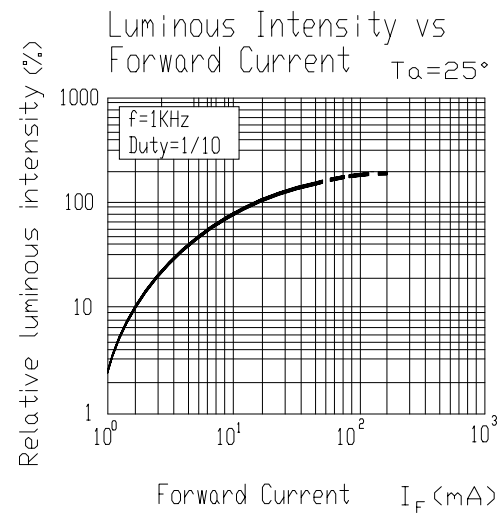
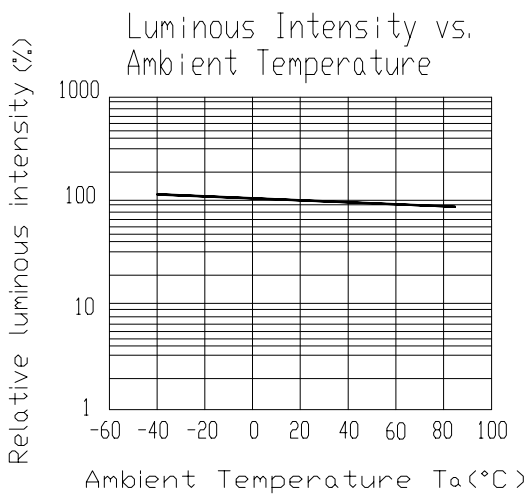
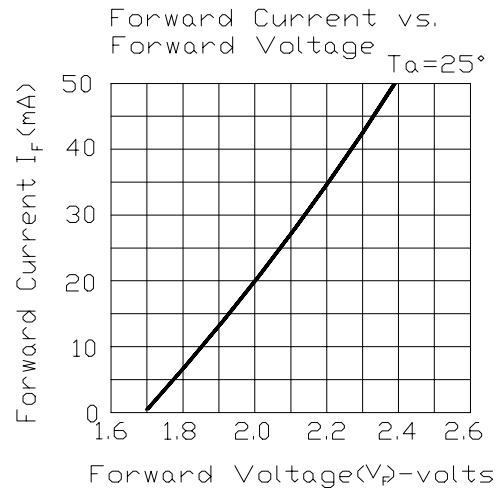
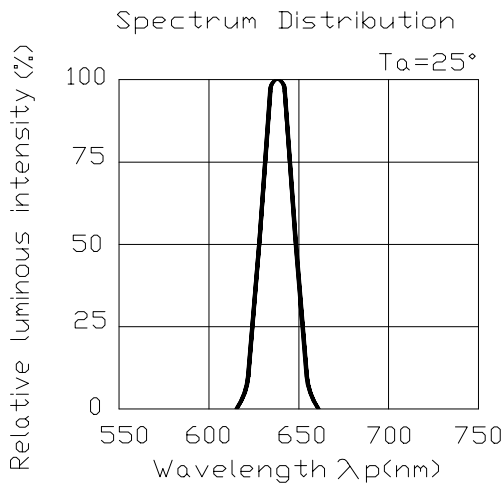

95-21USRC/S400-XX/XXX**Reliability Test Items And Conditions**

The reliability of products shall be satisfied with items listed below.

Confidence level : 90 %

LTPD : 10 %

No.	Items	Test Condition	Test Hours/Cycles	Sample Size	Ac/Rc
1	Reflow	Temp. : 240°C ± 5°C Min. 5 sec.	5 Sec.	22 Pcs.	0/1
2	Temperature Cycle	H : +100°C 15 min. ∫ 5 min. L : -40°C 15 min.	300 Cycles	22 Pcs.	0/1
3	Thermal Shock	H : +100°C 5 min. ∫ 10 sec. L : -10°C 5 min.	300 Cycles	22 Pcs.	0/1
4	High Temperature Storage	Temp. : 100°C	1000 Hrs.	22 Pcs.	0/1
5	Low Temperature Storage	Temp. : -55°C	1000 Hrs.	22 Pcs.	0/1
6	DC Operating Life	IF = 20 mA	1000 Hrs.	22 Pcs.	0/1
7	High Temperature / High Humidity	85°C/RH 85%	1000 Hrs.	22 Pcs.	0/1

Precautions For Use

1. Over-current-proof

Customer must apply resistors for protection , otherwise slight voltage shift will cause big current change (Burn out will happen).

2. Storage time

2.1 The operation of Temperature and RH are : 5°C~35°C, RH60%.

2.2 Once the package is opened, the products should be used within a week. Otherwise, they should be kept in a damp proof box with descanting agent. Considering the tape life , we suggest our customers to use our products within a year(from production date).

2.3 If opened more than one week in an atmosphere 5°C~35°C, RH 60%, they should be treated at 60°C± 5°C for 15hrs.

2.4 When you discover that the desiccant in the package has a pink color (Normal = blue) , you should treat them in the same conditions as 2.3.

Soldering heat

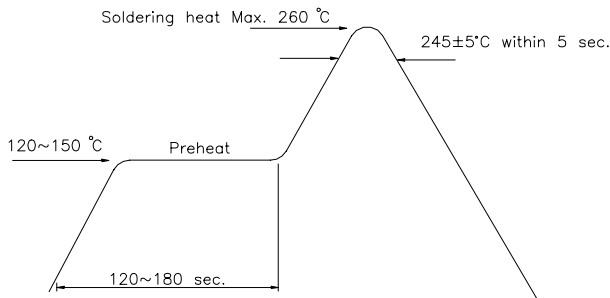

Reflow Temp / Time

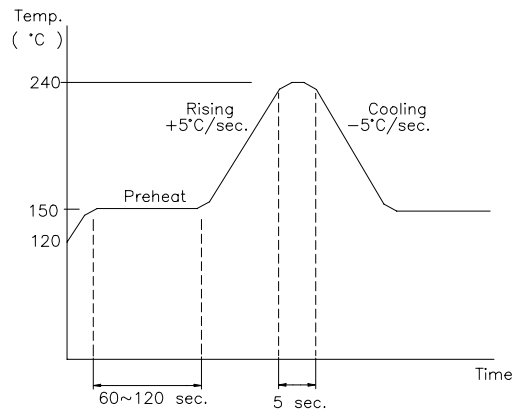

Soldering Iron

Basic spec is ≤ 5 sec when 260°C . If temperature is higher, time should be shorter ($+10^{\circ}\text{C} \rightarrow -1\text{sec}$). Power dissipation of Iron should be smaller than 15 W, and temperature should be controllable. Surface temperature of the device should be under 230°C .

Rework

1. Customer must finish rework within 5 sec under 245°C .
2. The head of iron can not touch copper foil.
3. Twin-head type is preferred.

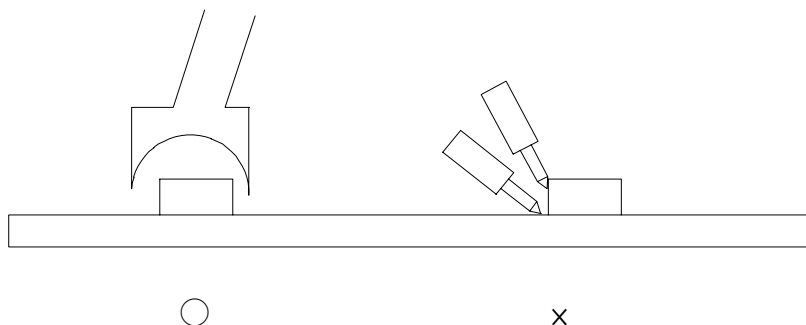
**EVERLIGHT ELECTRONICS CO., LTD.**

Office: No 25, Lane 76, Sec 3, Chung Yang Rd,
Tucheng, Taipei 236, Taiwan, R.O.C

Tel: 886-2-2267-2000, 2267-9936

Fax: 886-2267-6244, 2267-6189, 2267-6306

<http://www.everlight.com>