



Technical Data Sheet

White SMD Surface Mount Device

67-21UWC/1B/TR8

Features

- Fluorescence Type
- High Luminous Intensity
- High Efficiency
- Emission Color:x=0.29,y=0.30

Descriptions

The white LED which was fabricated using a blue LED and a phosphor, and the phosphor is excited by blue light and emits yellow fluorescence. The mixture of blue light and yellow light results in a white emission.



Applications

- OA Equipment
- Backlighting of Full Color LCD
- Automotive Equipment
- Replacement of Conventional Light Bulbs and Fluorescent Lamps

Device Selection Guide

Chip		Lens Color
Material	Emitted Color	
InGaN	White	Water Clear

Package Dimensions

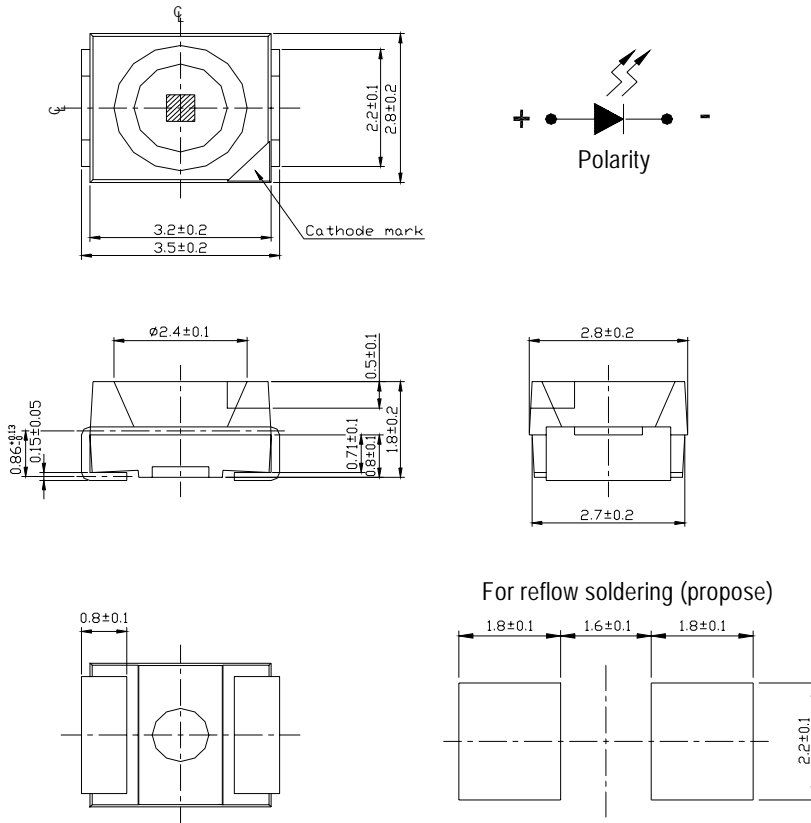

Notes: .All dimensions are in millimeters

Absolute Maximum Ratings (Ta=25)

Parameter	Symbol	Rating	Units
Forward Current	I _F	30	mA
Pulse Forward Current ^{*1}	I _{FP}	100	mA
Reverse Voltage	V _R	5	V
Power Dissipation	P _d	120	mW
Operating Temperature	T _{opr}	-30 ~ +80	
Storage Temperature	T _{stg}	-40 ~ +100	
Soldering Temperature ^{*2}	T _{sol}	260	
Electrostatic Discharge	ESD	150	V

Notes: *1:I_{FP} Conditions--Pulse Width 10msec and Duty 1/10.

*2:Soldering time 5 seconds.

Electro-Optical Characteristics (Ta=25)

Parameter	Symbol	Condition	Min.	Typ.	Max.	Units
Forward Voltage	V _F	I _F =20mA	--	3.6	4.0	V
Reverse Current	I _R	V _R =5V	--	--	10	μ A
Luminous Intensity	I _V	I _F =20mA	100	160	--	mcd
Viewing Angle	2 1/2	I _F =20mA	--	120	--	deg
Chromaticity* ¹	x	I _F =10mA	--	0.29	--	
Coordinates	y		--	0.30	--	

Notes: *The C.I.E. 1931 chromaticity diagram.

*The products are sensitive to static electricity and care must be fully taken when handling products.

Chromaticity Coordinates Specifications for Bin Grading

Rank	Chromaticity Coordinates					
	A	x	0.220	0.220	0.260	0.260
	y	0.220	0.280	0.310	0.250	
B	x	0.260	0.260	0.290	0.290	
	y	0.250	0.310	0.330	0.270	
C	x	0.290	0.290	0.320	0.320	
	y	0.270	0.330	0.350	0.290	
D	x	0.320	0.320	0.360	0.360	
	y	0.290	0.350	0.380	0.320	
* Tolerance		x±0.02			y±0.02	

CIE Chromaticity Diagram

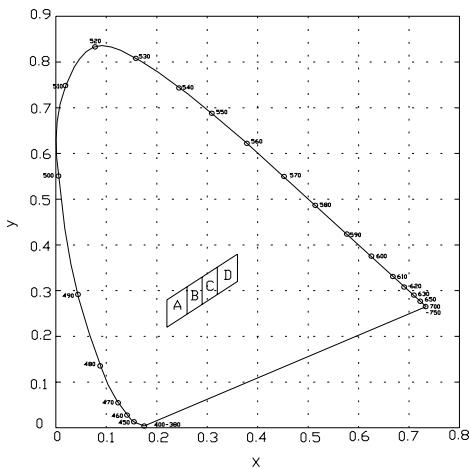

Typical Electro-Optical Characteristics Curves

· Forward Current vs. Forward Voltage

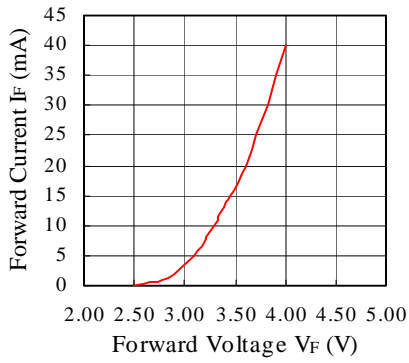

· Forward Voltage vs. Ambient Temperature

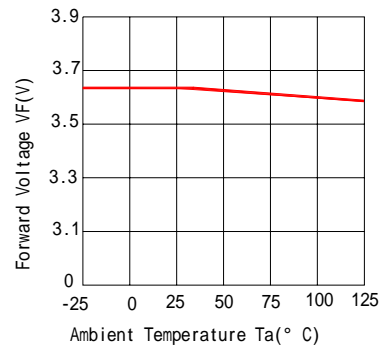

· Relative Intensity vs. Ambient Temperature

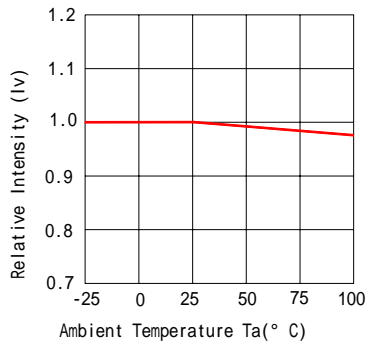

· Forward Current vs. Ambient Temperature

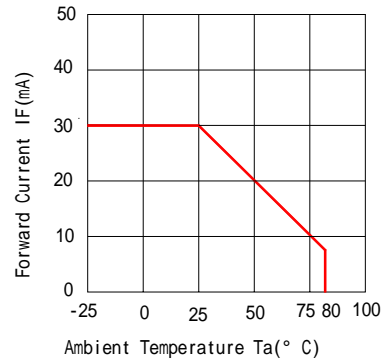

· Luminous Spectrum ($T_a=25^\circ$)

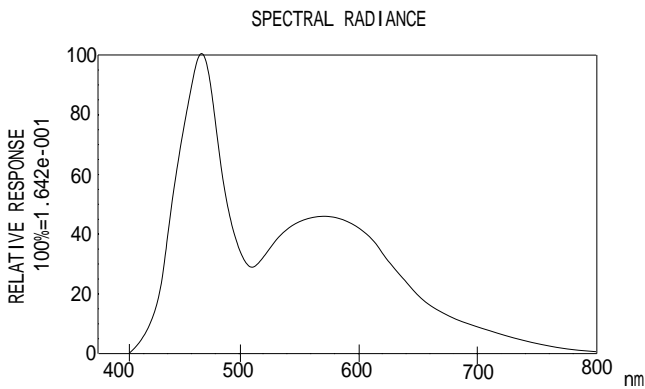

· Directivity Radiation Angle: 120 degree (Typ.)

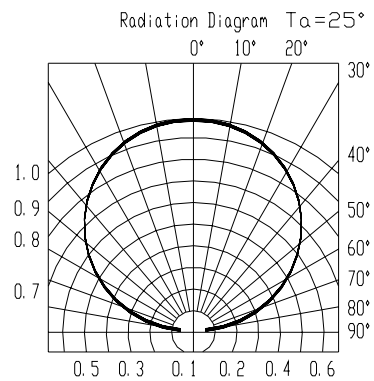

Package Dimension

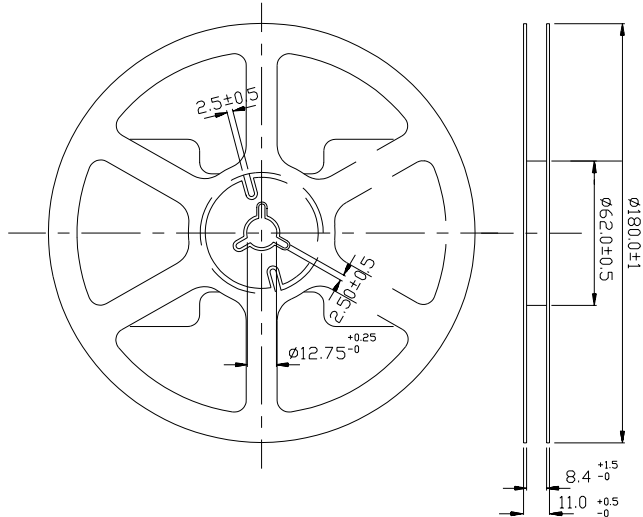

Loaded quantity 2000pcs/reel and used by ESD reel(black reel)

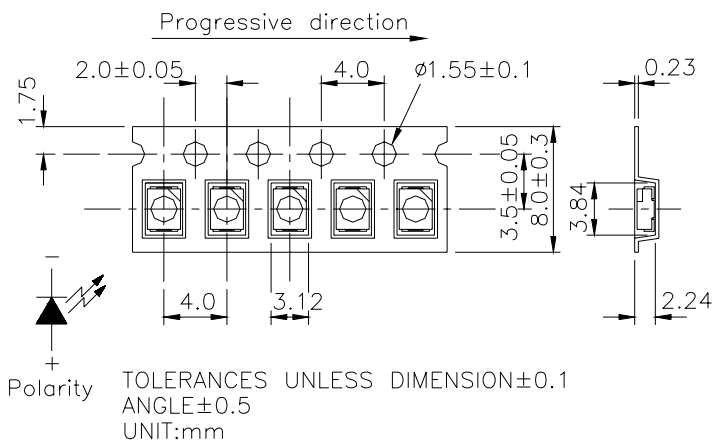

Soldering heat reliability (DIP)

Reflow Temp / Time

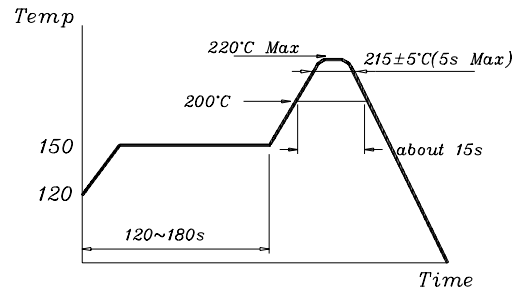
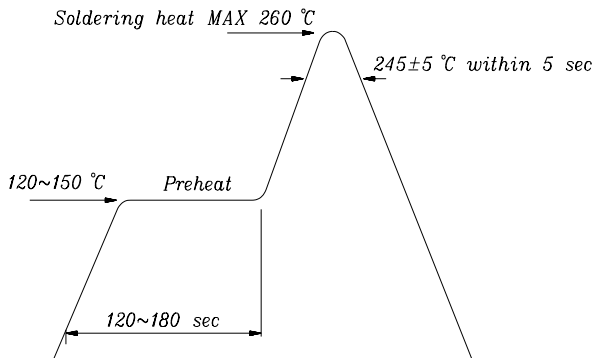

Soldering Iron

Basic spec is 5 sec when 260 . If temperature is higher, time should be shorter (+10 -1sec). Power dissipation of Iron should be smaller than 15 W , and temperature should be controllable. Surface temperature of the device should be under 230 .

Rework

1. Customer must finish rework within 5 sec under 245 .
2. The head of iron can not touch copper foil.
3. Twin-head type is preferred.

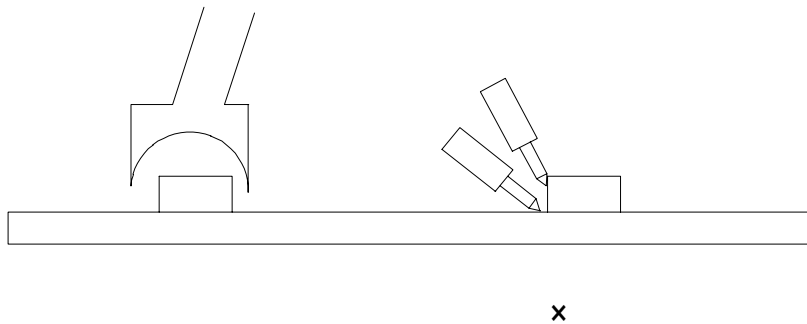

EVERLIGHT ELECTRONICS CO., LTD.
 Office: No 25, Lane 76, Sec 3, Chung Yang Rd,
 Tucheng, Taipei 236, Taiwan, R.O.C

Tel: 886-2-2267-2000, 2267-9936
 Fax: 886-2267-6244, 2267-6189, 2267-6306
<http://www.everlight.com>