



Technical Data Sheet

Full Color Top View LEDs

67-03/B7GBRSW-B12/2T/MS

Features

- P-LCC-4 package.
- White package and black surface.
- Optical indicator.
- Inter reflector.
- Wide viewing angle.
- Suitable for vapor-phase reflow, Infrared reflow and wave solder processes.
- Computable with automatic placement equipment.
- Available on tape and reel (8mm Tape).
- Pb-free.
- The product itself will remain with RoHS compliant version

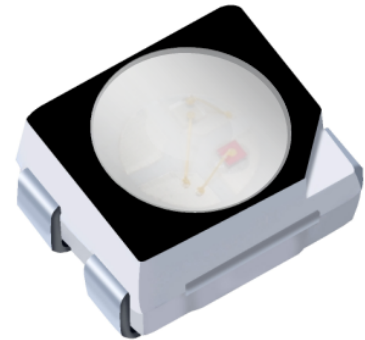

Descriptions

- The 67-03 series is available in soft orange, green, blue and yellow. Due to the package design, the LED has wide viewing angle and optimized light coupling by inter reflector. This feature makes the LED ideal for light pipe application. The low current requirement makes this device ideal for portable equipment or any other application where power is at a premium.

Applications

- Telecommunication: indicator and backlighting in telephone and fax.
- Flat backlight for LCD's, switches and symbols.
- Light pipe application.
- General use.

Device Selection Guide

Chip		Emitted Color	Resin Color
Type	Material		
RS	AlGaInP	Brilliant Red	White Diffuse
GB	InGaN	Brilliant Green	
B7	InGaN	Blue	

Technical Data Sheet

Full Color Top View LEDs

67-03/B7GBRSW-B12/2T/MS

Package Outline Dimensions

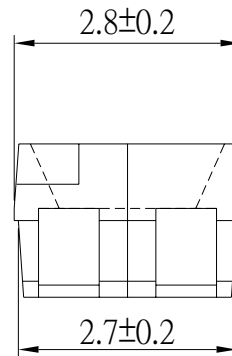
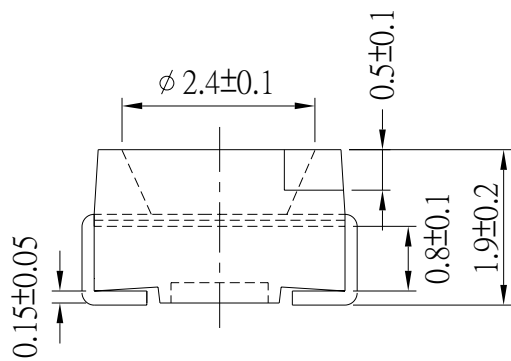
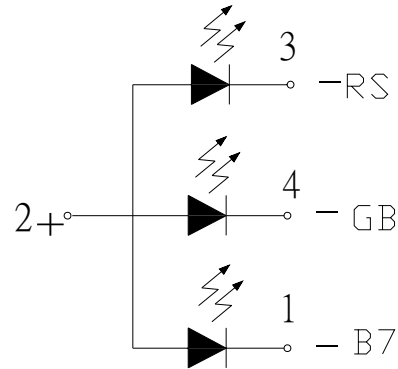
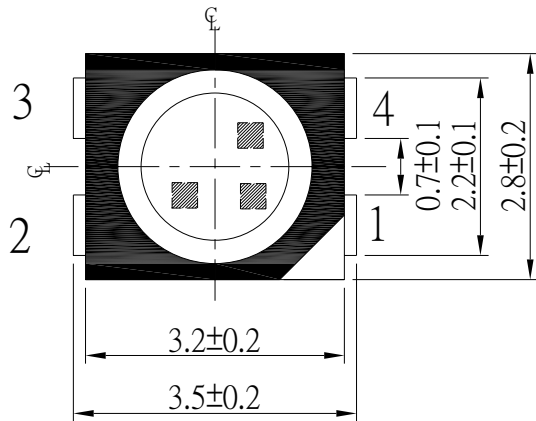

Recommended soldering pad design

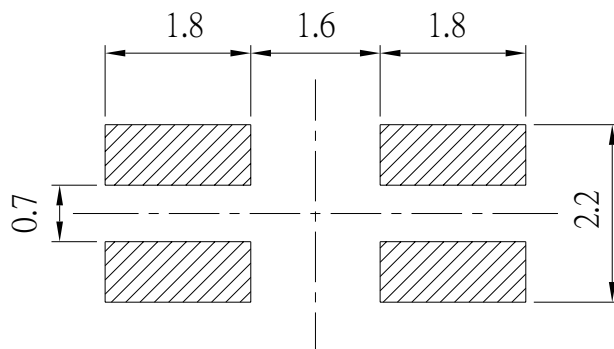
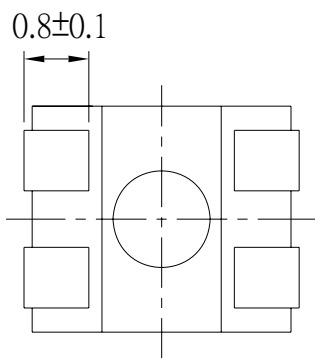

Notes:

1. All dimensions are in millimeters
2. Tolerance unless mentioned is ± 0.1 mm

**Technical Data Sheet****Full Color Top View LEDs****67-03/B7GBRSW-B12/2T/MS****Absolute Maximum Ratings (Ta=25°C)**

Parameter	Symbol	Rating		Unit
Reverse Voltage	V _R	5		V
Forward Current	I _F	RS	50	mA
		GB	30	
		B7	30	
Peak Forward Current (Duty 1/10 @ 1KHz)	I _{FP}	RS	100	mA
		GB	100	
		B7	100	
Power Dissipation	Pd	RS	120	mW
		GB	110	
		B7	110	
Electrostatic Discharge(HBM)	ESD	RS	2000	V
		GB	1000	
		B7	1000	
Operating Temperature	Topr	-40 ~ +85		°C
Storage Temperature	Tstg	-40~ +90		°C
Soldering Temperature	Tsol	Reflow Soldering : 260 °C for 10 sec. Hand Soldering : 350 °C for 3 sec.		



Technical Data Sheet

Full Color Top View LEDs

67-03/B7GBRSW-B12/2T/MS

Electro-Optical Characteristics (Ta=25°C)

Parameter	Symbol	Min.	Typ.	Max.	Unit	Condition	
Luminous Intensity	I _v	RS	575	-----	825	mcd	I _F =20mA
		GB	1000	-----	1450		
		B7	275	-----	395		
Peak Wavelength	λ _p	RS	-----	632	-----	nm	I _F =20mA
		GB	-----	518	-----		
		B7	-----	468	-----		
Dominant Wavelength	λ _d	RS	618	-----	627	nm	I _F =20mA
		GB	524	-----	531.5		
		B7	466.5	-----	474		
Spectrum Radiation Bandwidth	Δλ	RS	-----	20	-----	nm	I _F =20mA
		GB	-----	35	-----		
		B7	-----	35	-----		
Forward Voltage	V _F	RS	1.75	-----	2.35	V	I _F =20mA
		GB	2.95	-----	3.55		
		B7	2.75	-----	3.35		
Viewing Angle	201/2	-----	120	-----	deg	I _F =20mA	
Reverse Current	I _R	RS	-----	-----	10	μA	V _R =5V
		GB	-----	-----	50		
		B7	-----	-----	50		

Note:

1. Tolerance of Luminous Intensity: ±10%
2. Tolerance of Dominant Wavelength: ±1nm
3. Tolerance of Forward Voltage: ±0.1V



Technical Data Sheet

Full Color Top View LEDs

67-03/B7GBRSW-B12/2T/MS

Bin Range of Luminous Intensity

Symbol		Bin Code	Min.	Max.	Unit	Condition
I _v	RS	10b	575	630	mcd	I _F =20mA
		11a	630	690		
		11b	690	756		
		12a	756	825		
	GB	13b	1000	1100		
		14a	1100	1200		
		14b	1200	1320		
		15a	1320	1450		
	B7	6b	275	300		
		7a	300	330		
		7b	330	360		
		8a	360	395		

Note:

Tolerance of Luminous Intensity: ±10%



Technical Data Sheet

Full Color Top View LEDs

67-03/B7GBRSW-B12/2T/MS**Bin Range of Dominant Wavelength**

Symbol		Bin Code	Min.	Max.	Unit	Condition
λ_d	RS	R1	618	621	nm	$I_F=20\text{mA}$
		R2	621	624		
		R3	624	627		
	GB	G1	524	526.5		
		G2	526.5	529		
		G3	529	531.5		
	B7	B1	466.5	469		
		B2	469	471.5		
		B3	471.5	474		

Bin Range of Forward Voltage

Symbol		Bin Code	Min.	Max.	Unit	Condition
V_F	RS	0	1.75	1.95	V	$I_F=20\text{mA}$
		1	1.95	2.15		
		2	2.15	2.35		
	GB	11	2.90	3.10		
		12	3.10	3.30		
		13	3.30	3.50		
	B7	A	2.75	2.95		
		B	2.95	3.15		
		C	3.15	3.35		

Note:

1. Tolerance of Dominant Wavelength: $\pm 1\text{nm}$
2. Tolerance of Forward Voltage: $\pm 0.1\text{V}$



Technical Data Sheet

Full Color Top View LEDs

67-03/B7GBRSW-B12/2T/MS

Typical Electro-Optical Characteristics Curves (B7)

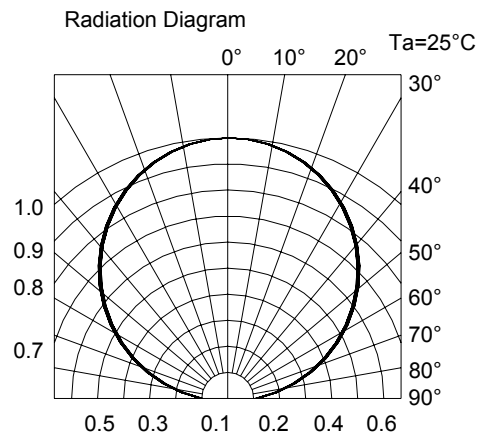
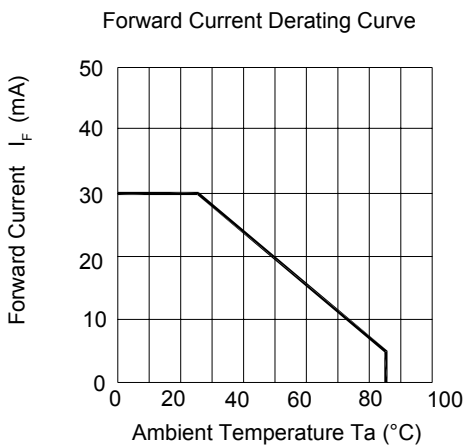
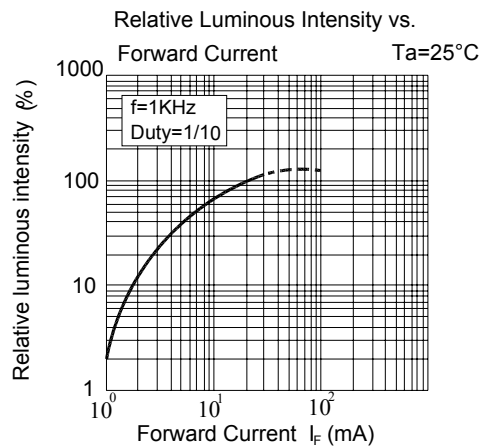
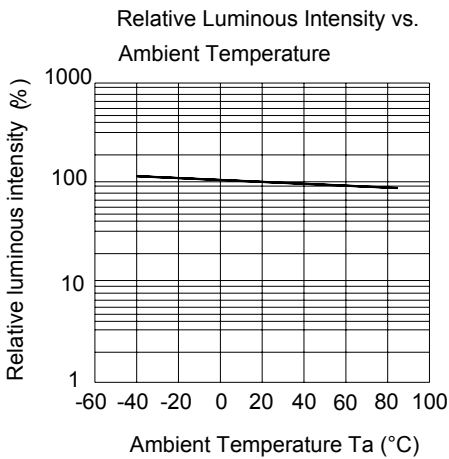
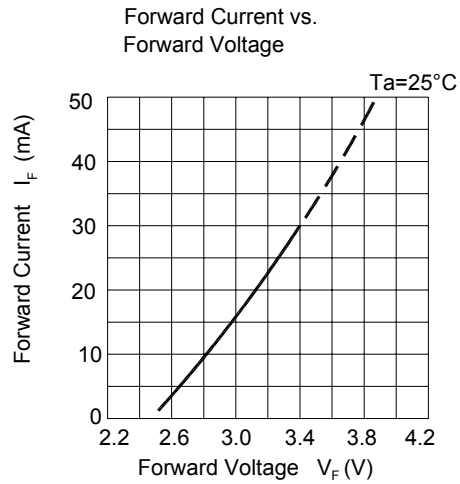
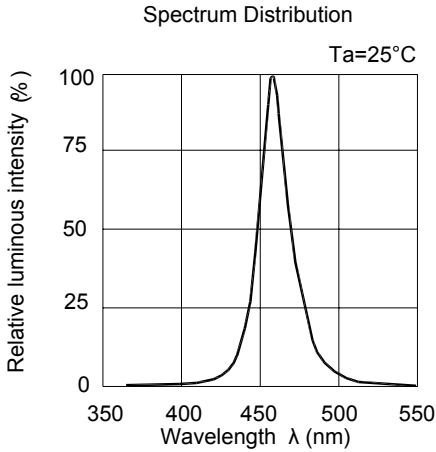



Technical Data Sheet

Full Color Top View LEDs

67-03/B7GBRSW-B12/2T/MS

Typical Electro-Optical Characteristics Curves (GB)

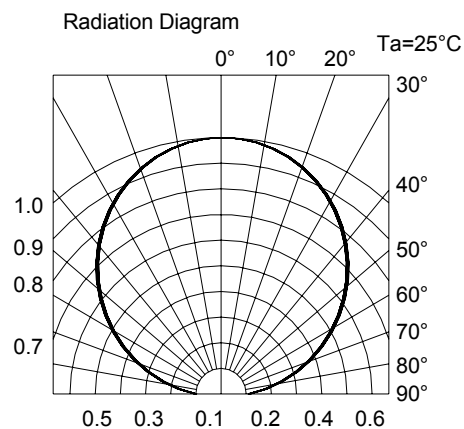
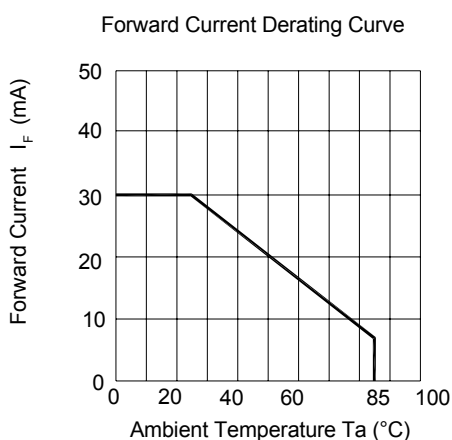
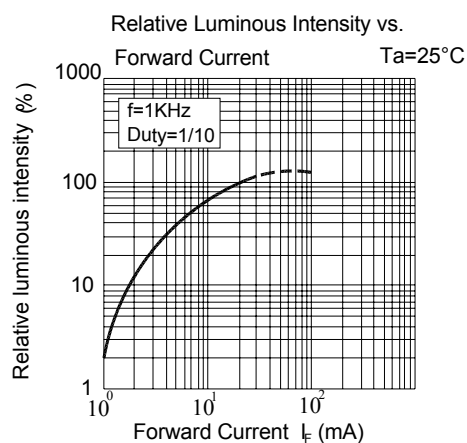
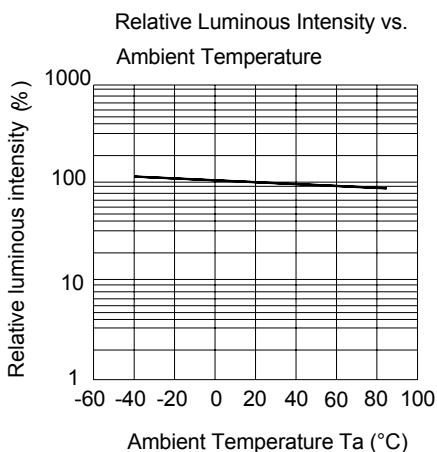
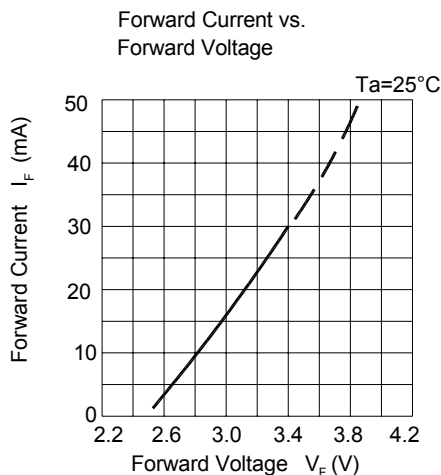
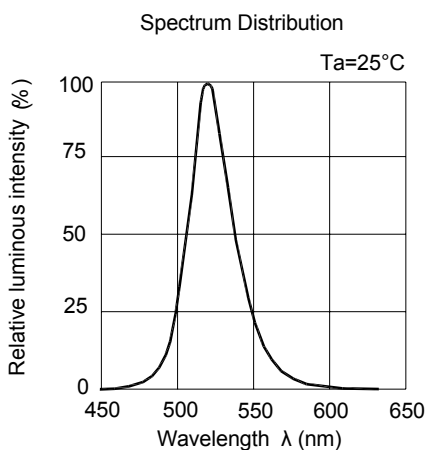



Technical Data Sheet

Full Color Top View LEDs

67-03/B7GBRSW-B12/2T/MS

Typical Electro-Optical Characteristics Curves (RS)

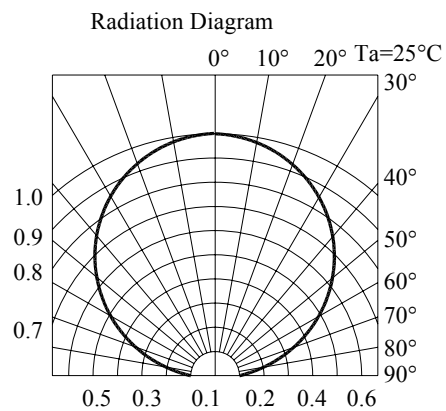
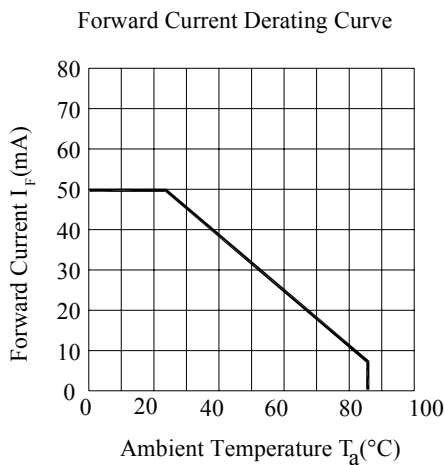
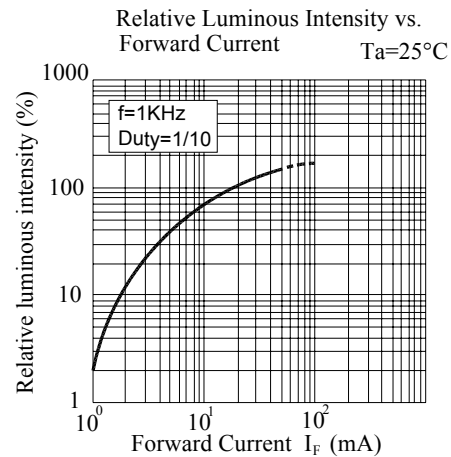
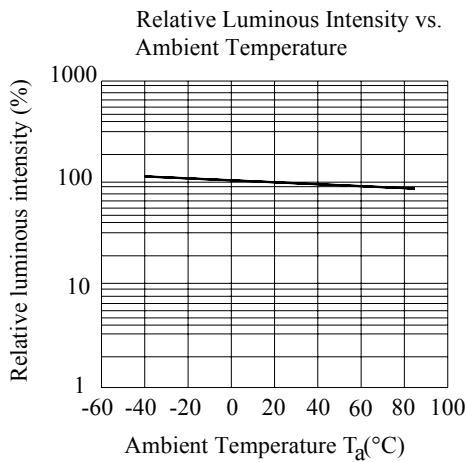
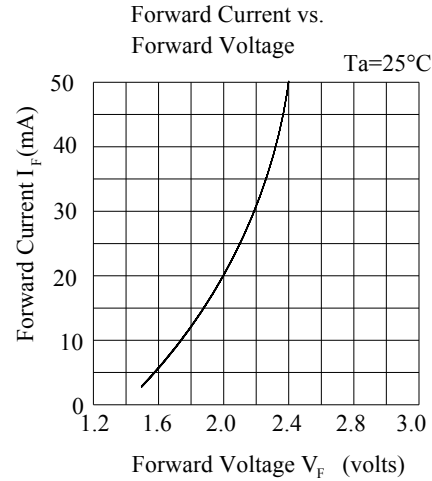
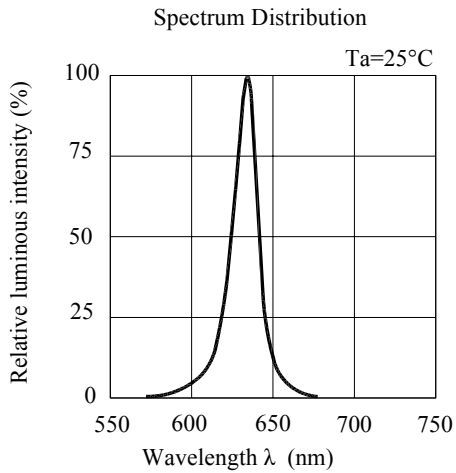



Technical Data Sheet

Full Color Top View LEDs

67-03/B7GBRSW-B12/2T/MS

Label Explanation

CAT: Luminous Intensity Rank

HUE: Dom. Wavelength Rank

REF: Forward Voltage Rank

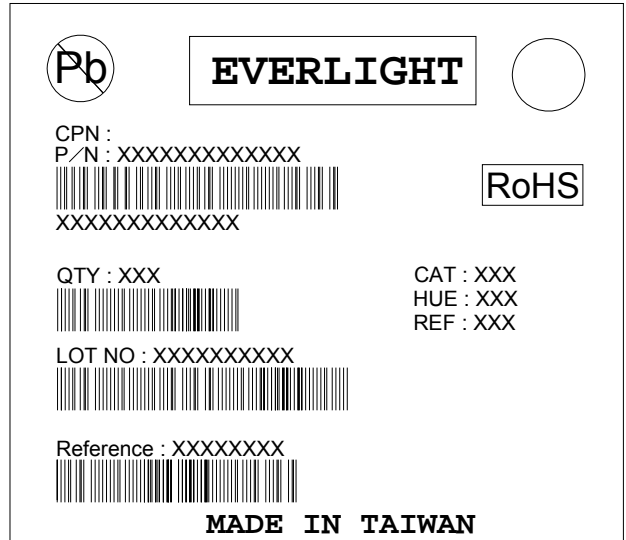

Reel Dimensions

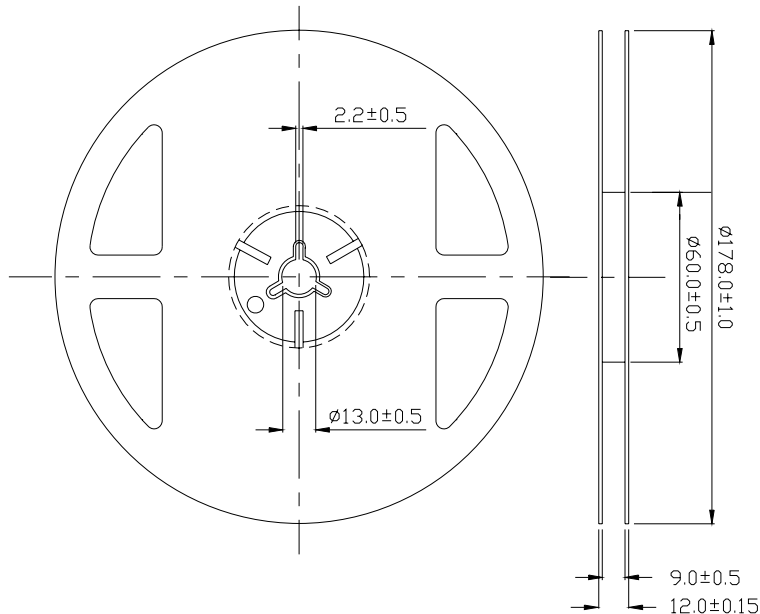

Note: Tolerance unless mentioned is ±0.1mm; Unit = mm



Technical Data Sheet

Full Color Top View LEDs

67-03/B7GBRSW-B12/2T/MS

Carrier Tape Dimensions: Loaded Quantity 2000 pcs Per Reel.

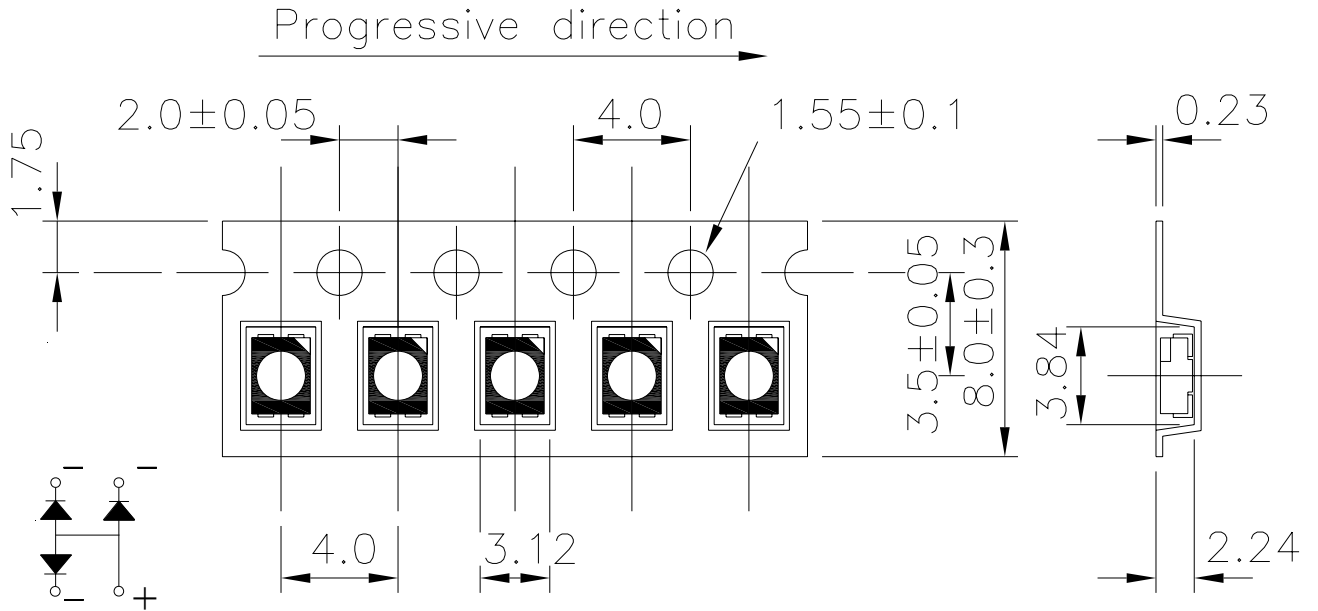

Note: Tolerance unless mentioned is ±0.1mm; Unit = mm

Moisture Resistant Packaging

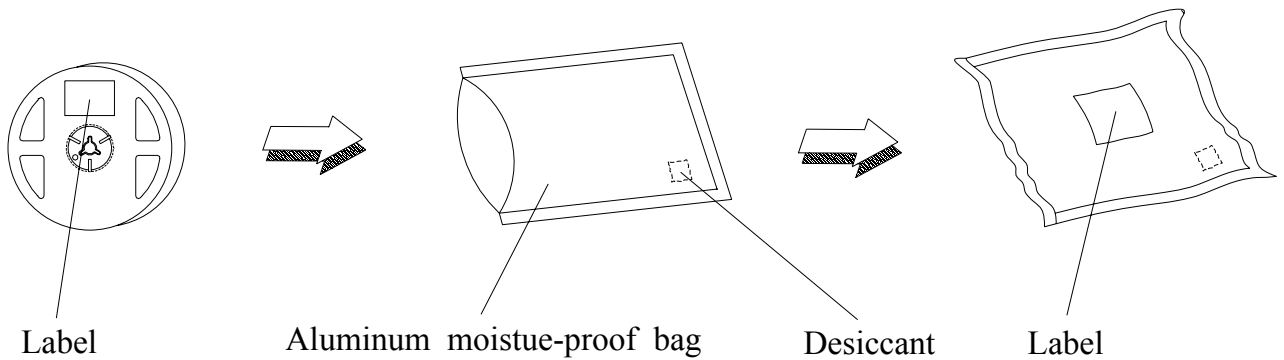

**Technical Data Sheet****Full Color Top View LEDs****67-03/B7GBRSW-B12/2T/MS****Reliability Test Items and Conditions**

The reliability of products shall be satisfied with items listed below.

Confidence level : 90%

LTPD : 10%

No.	Items	Test Condition	Test Hours/Cycles	Sample Size	Ac/Re
1	Reflow Soldering	Temp. : 260°C±5°C Min. 5sec.	6 Min.	22 PCS.	0/1
2	Temperature Cycle	H : +100°C 15min ↓ 5 min L : -40°C 15min	300 Cycles	22 PCS.	0/1
3	Thermal Shock	H : +100°C 5min ↓ 10 sec L : -10°C 5min	300 Cycles	22 PCS.	0/1
4	High Temperature Storage	Temp. : 100°C	1000 Hrs.	22 PCS.	0/1
5	Low Temperature Storage	Temp. : -40°C	1000 Hrs.	22 PCS.	0/1
6	DC Operating Life	I _F = 20 mA	1000 Hrs.	22 PCS.	0/1
7	High Temperature / High Humidity	85°C / 85%RH	1000 Hrs.	22 PCS.	0/1

Technical Data Sheet

Full Color Top View LEDs

67-03/B7GBRSW-B12/2T/MS

Precautions for Use

1. Over-current-proof

Customer must apply resistors for protection; otherwise slight voltage shift will cause big current change (Burn out will happen).

2. Storage

2.1 Do not open moisture proof bag before the products are ready to use.

2.2 Before opening the package: The LEDs should be kept at 30°C or less and 90%RH or less.

2.3 After opening the package: The LED's floor life is 168 hours under 30°C or less and 60% RH or less. If unused LEDs remain, it should be stored in moisture proof packages.

2.4 If the moisture absorbent material (silica gel) has faded away or the LEDs have exceeded the storage time, baking treatment should be performed using the following conditions.

Baking treatment: 60±5°C for 24 hours.

3. Soldering Condition

3.1 Pb-free solder temperature profile

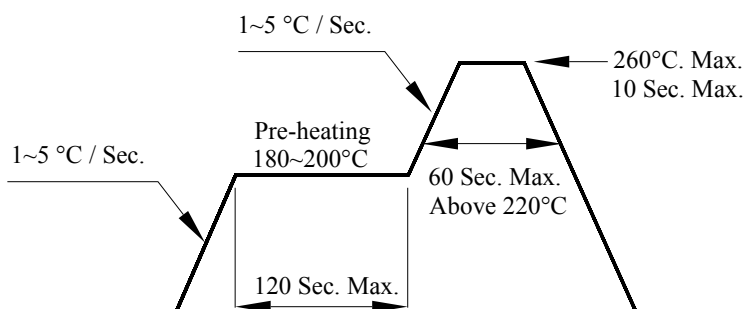

3.2 Reflow soldering should not be done more than two times.

3.3 When soldering, do not put stress on the LEDs during heating.

3.4 After soldering, do not warp the circuit board.

Technical Data Sheet**Full Color Top View LEDs****67-03/B7GBRSW-B12/2T/MS**

4. Soldering Iron

Each terminal is to go to the tip of soldering iron temperature less than 350°C for 3 seconds within once in less than the soldering iron capacity 25W. Leave two seconds and more intervals, and do soldering of each terminal. Be careful because the damage of the product is often started at the time of the hand solder.

5. Repairing

Repair should not be done after the LEDs have been soldered. When repairing is unavoidable, a double-head soldering iron should be used (as below figure). It should be confirmed beforehand whether the characteristics of the LEDs will or will not be damaged by repairing.

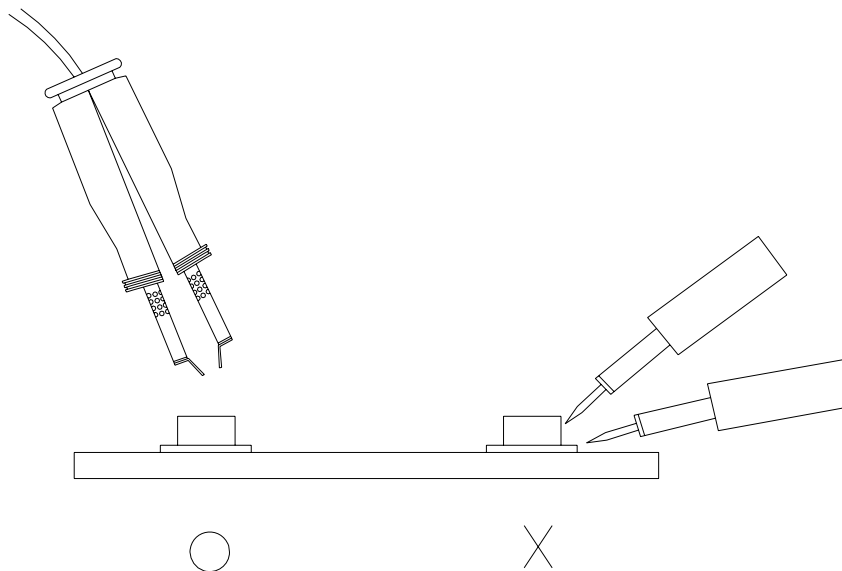

EVERLIGHT ELECTRONICS CO., LTD.
Office: No 25, Lane 76, Sec 3, Chung Yang Rd,
Tucheng, Taipei 236, Taiwan, R.O.C

Tel: 886-2-2267-2000, 2267-9936
Fax: 886-2267-6244, 2267-6189, 2267-6306
<http://www.everlight.com>