

Technical Data Sheet

Top View LEDs

65-21-B3T-A0S1T1A7E-2T8-AM

Lead (Pb) Free Product - RoHS Compliant



Feature

- RoHS compliant.
- P-LCC-2 package.
- Color diffused resin.
- Wide viewing angle 120°.
- Inner reflector and white package.
- Brightness: 180 to 355 mcd at 20mA.
- Qualification according to AEC-Q101 rev C.
- Precondition: Bases on JEDEC J-STD 020D Level 2.
- Automotive reflow profile (IR reflow or wave soldering).

Applications

- Automotive backlighting or indicator: Dashboard, switch, audio and video equipments...etc.
- Backlight: LCD, switches, symbol, mobile phone and illuminated advertising.
- Display for indoor and outdoor application.
- Ideal for coupling into light guides.
- Substitution of traditional light.
- Optical indicator.
- General applications.

Device Selection Guide

Chip	Emitted Color	Resin Color
Material		
InGaN/SiC	White	Yellowish

Technical Data Sheet

Top View LEDs

65-21-B3T-A0S1T1A7E-2T8-AM

Absolute Maximum Ratings (Ta=25°C)

Parameter	Symbol	Rating	Unit
Reverse Voltage	V_R	5	V
Forward Current	I_F	30	mA
Peak Forward Current (Duty 1/10 @1KHz)	I_{FP}	100	mA
Power Dissipation	P_d	120	mW
Junction Temperature	T_j	125	°C
Operating Temperature	T_{opr}	-40 ~ +100	°C
Storage Temperature	T_{stg}	-40 ~ +110	°C
Thermal Resistance	$R_{th\ J-A}$	500	K/W
	$R_{th\ J-S}$	300	K/W
ESD (Classification acc. AEC Q101)	ESD_{HBM}	2000	V
	ESD_{MM}	200	V
Soldering Temperature	T_{sol}	Reflow Soldering : 260 °C for 30 sec. Hand Soldering : 350 °C for 3 sec.	

Technical Data Sheet

Top View LEDs

65-21-B3T-A0S1T1A7E-2T8-AM

Electro-Optical Characteristics (Ta=25°C)

Parameter	Symbol	Min.	Typ.	Max.	Unit	Condition
Luminous Intensity	I_v	180	---	355	mcd	$I_F = 20\text{mA}$
Viewing Angle	$2\theta_{1/2}$	---	120	---	deg	$I_F = 20\text{mA}$
Forward Voltage	V_F	2.7	---	3.8	V	$I_F = 20\text{mA}$
Reverse Current	I_R	---	---	10	μA	$V_R = 5\text{V}$
Temperature coefficient of V_F	TC_V	---	-1.7	---	mV/K	$I_F = 20\text{mA}$

Note:

1. Tolerance of Luminous Intensity: $\pm 11\%$
2. Tolerance of Dominant Wavelength: $\pm 1\text{nm}$
3. Tolerance of Forward Voltage: $\pm 0.1\text{V}$

Technical Data Sheet**Top View LEDs****65-21-B3T-A0S1T1A7E-2T8-AM****Bin Range of Luminous Intensity**

Bin Code	Min.	Max.	Unit	Condition
S1	180	224	mcd	I _F =20mA
S2	224	280		
T1	280	355		

Note:

Tolerance of Luminous Intensity: $\pm 11\%$

Technical Data Sheet

Top View LEDs

65-21-B3T-A0S1T1A7E-2T8-AM

Bin Range of Chromaticity Coordinates

Bin Code	CIE_x	CIE_y	Condition
A0	0.280	0.248	I _F =5mA
	0.264	0.267	
	0.264	0.267	
	0.283	0.305	

Note:

Tolerance of Chromaticity Coordinates: ±0.01.

Technical Data Sheet

Top View LEDs

65-21-B3T-A0S1T1A7E-2T8-AM

The C.I.E. 1931 Chromaticity Diagram

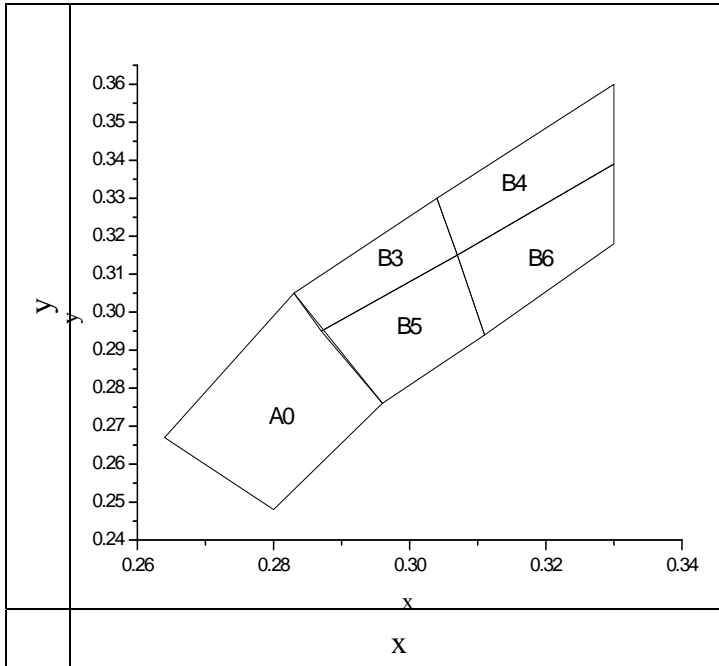

Technical Data Sheet

Top View LEDs

65-21-B3T-A0S1T1A7E-2T8-AM

Typical Electro-Optical Characteristics Curves

Typical Curve of Spectral Distribution

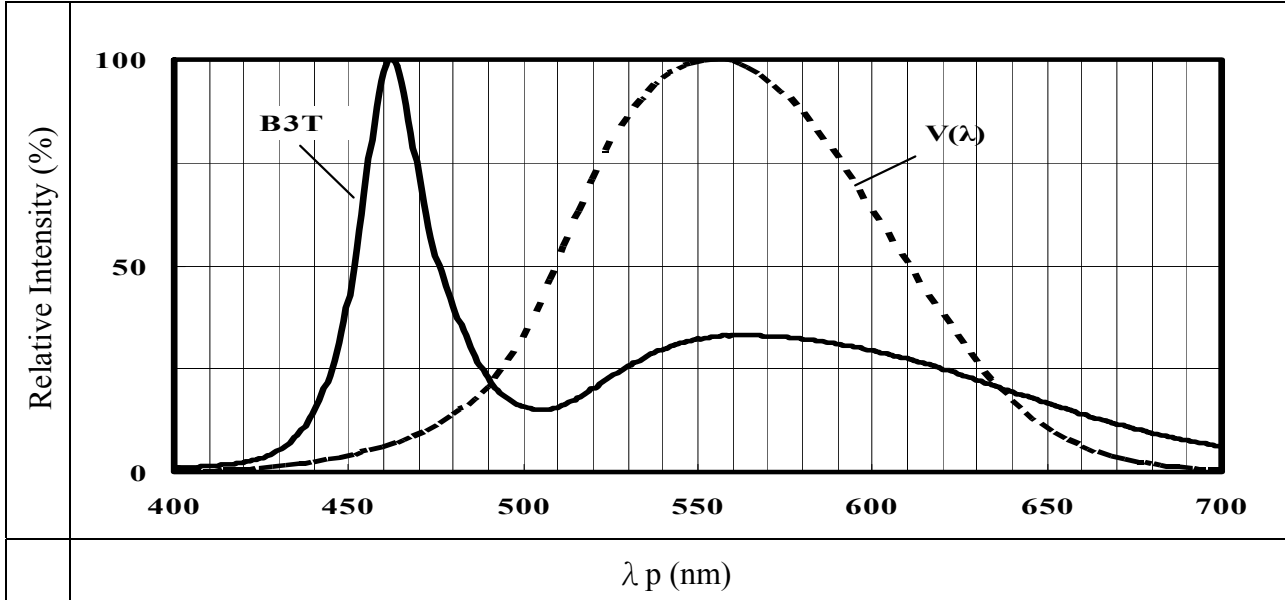

Note: V(λ)=Standard eye response curve; I_F =20mA

Diagram Characteristics of Radiation

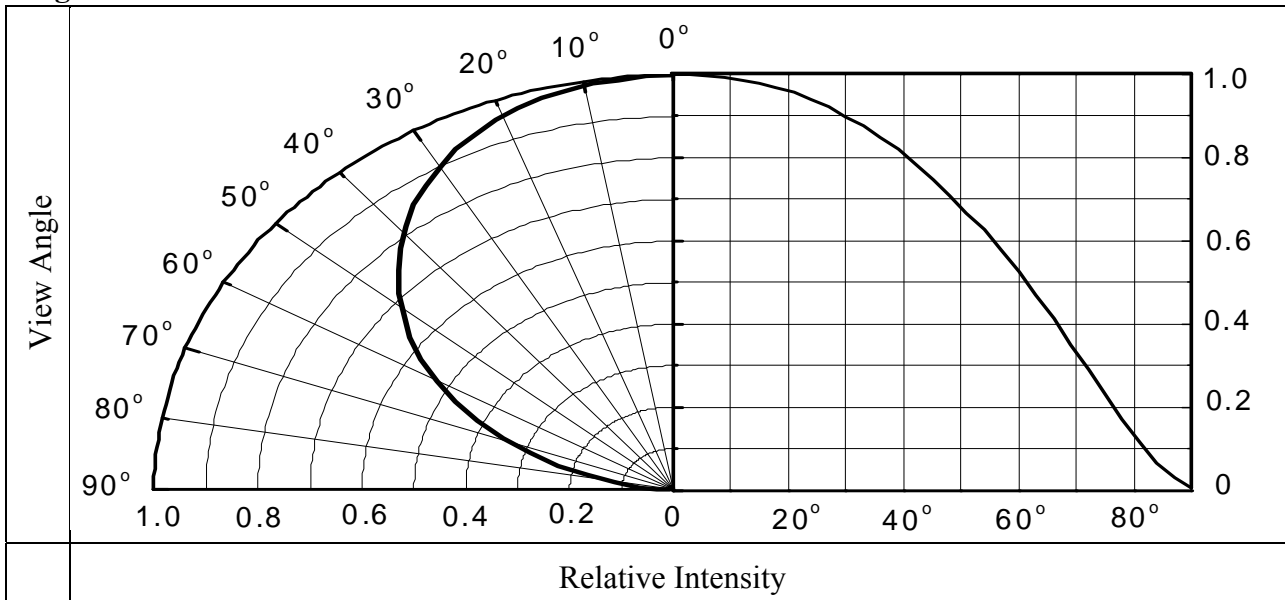

Technical Data Sheet

Top View LEDs

65-21-B3T-A0S1T1A7E-2T8-AM

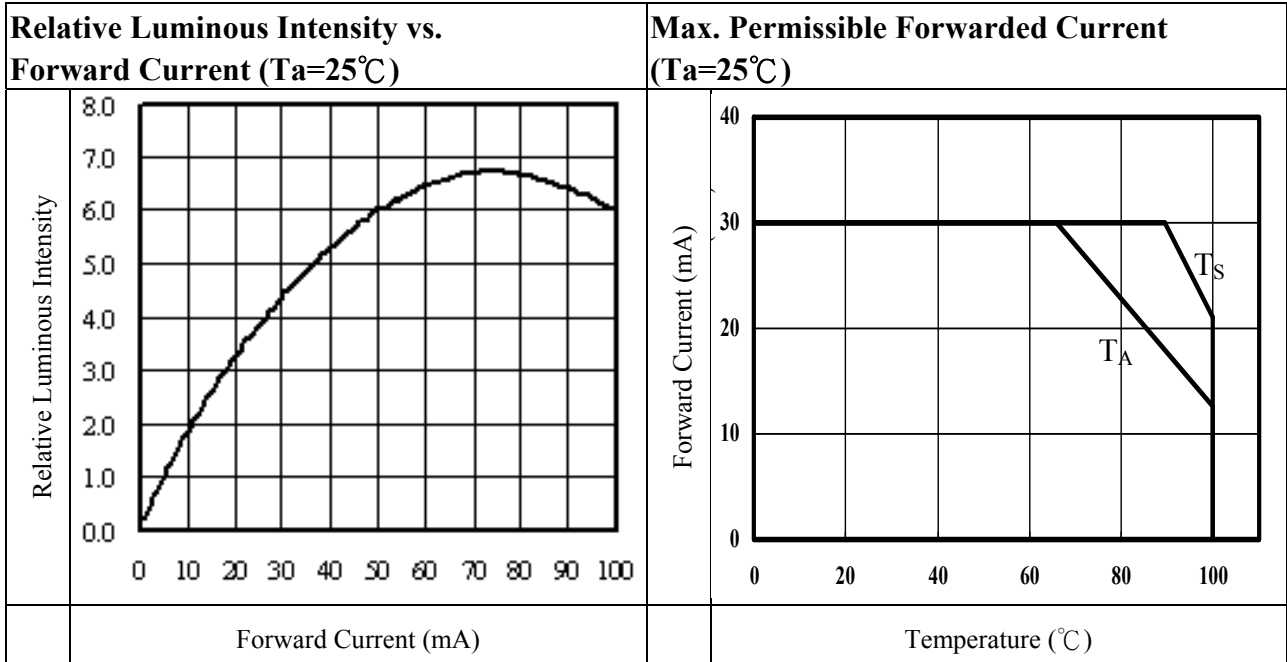
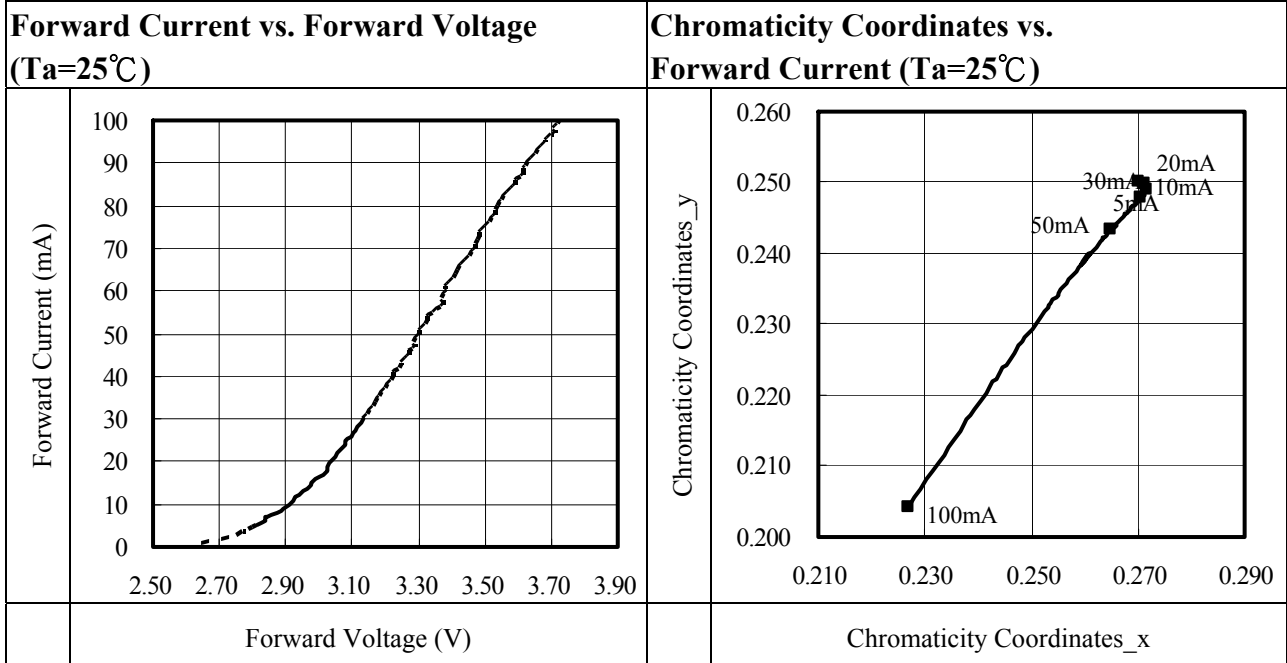

Technical Data Sheet

Top View LEDs

65-21-B3T-A0S1T1A7E-2T8-AM

Relative Luminous Intensity vs. Junction Temperature	Relative Forward Voltage vs. Junction Temperature
<p style="text-align: center;">Junction Temperature (°C)</p>	<p style="text-align: center;">Junction Temperature (°C)</p>
<p>Note: $f(T_j) = I_v / I_v(25^\circ\text{C}); I_F = 20\text{mA}$</p>	<p>Note: $\Delta V_F = V_F - V_F(25^\circ\text{C}) = f(T_j); I_F = 20\text{mA}$</p>

Technical Data Sheet

Top View LEDs

65-21-B3T-A0S1T1A7E-2T8-AM

Package Dimension

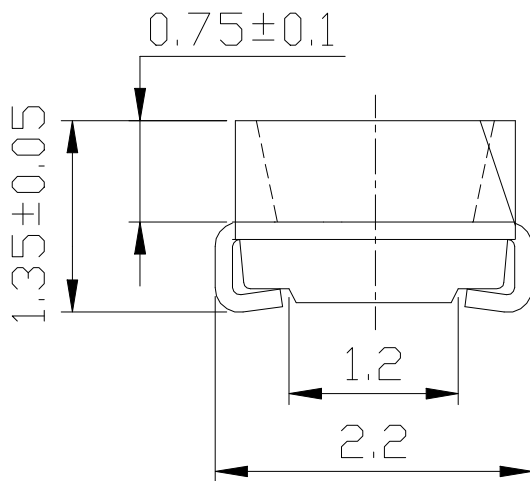
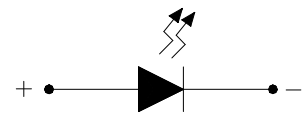
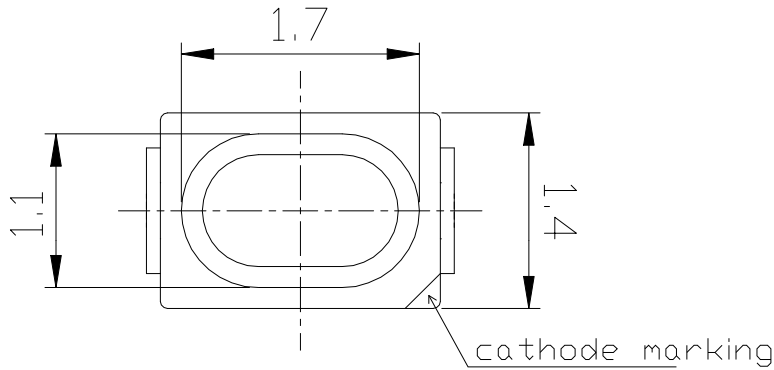

Polarity

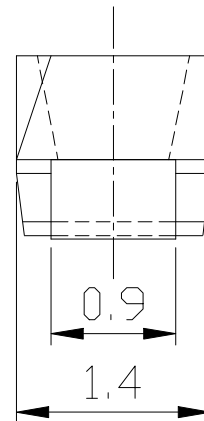

Note: Tolerances unless mentioned ± 0.1 mm. Unit = mm

Technical Data Sheet

Top View LEDs

65-21-B3T-A0S1T1A7E-2T8-AM

Moisture Resistant Packing Process and Materials Process

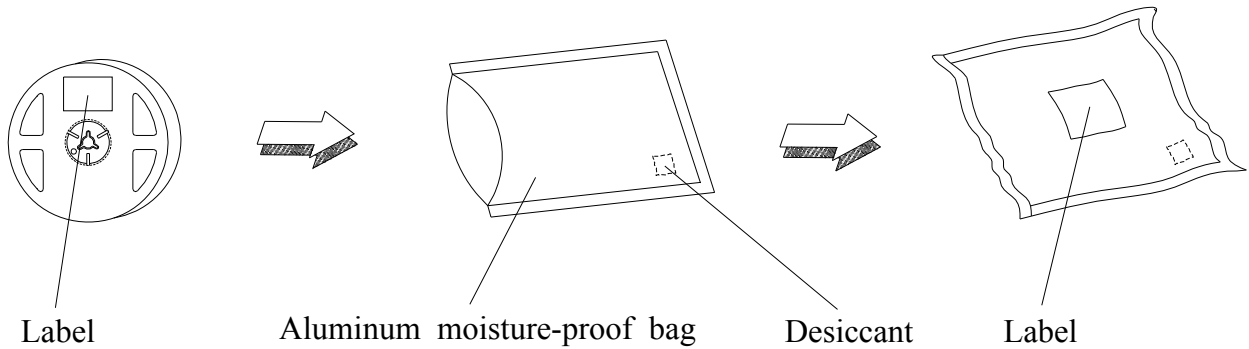

Carrier Tape Dimensions: Loaded Quantity 2000 pcs Per Reel

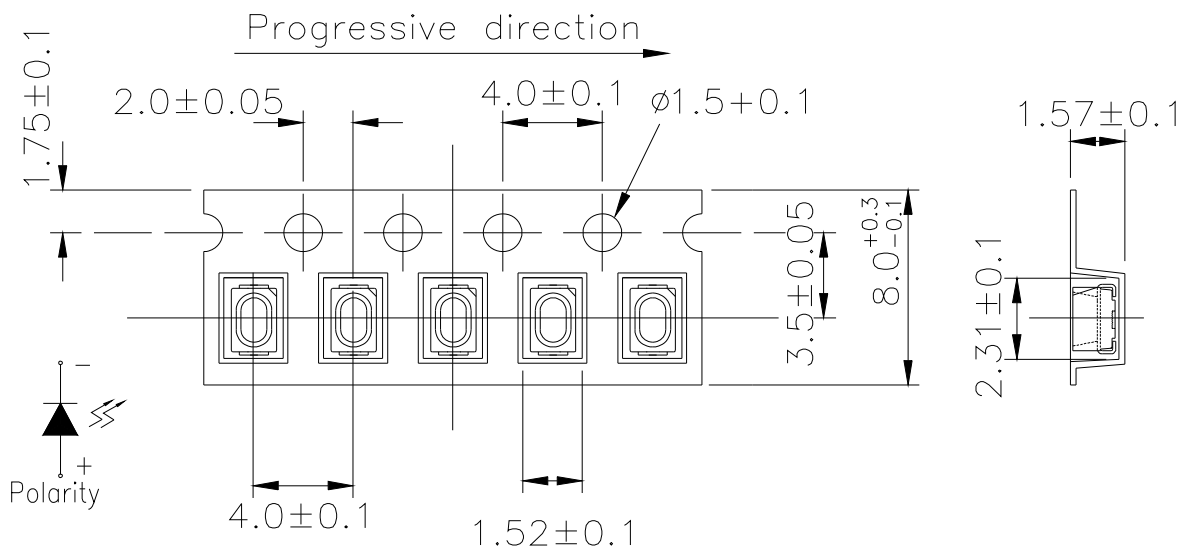

Note: Tolerances unless mentioned ± 0.1 mm. Unit = mm

Technical Data Sheet

Top View LEDs

65-21-B3T-A0S1T1A7E-2T8-AM

Label Explanation

- CPN: Customer's Product Number
- P/N: Product Number
- QTY: Packing Quantity
- CAT: Luminous Intensity Rank
- HUE: Chromaticity Coordinates Rank
- REF: Forward Voltage Rank
- LOT No: Lot Number

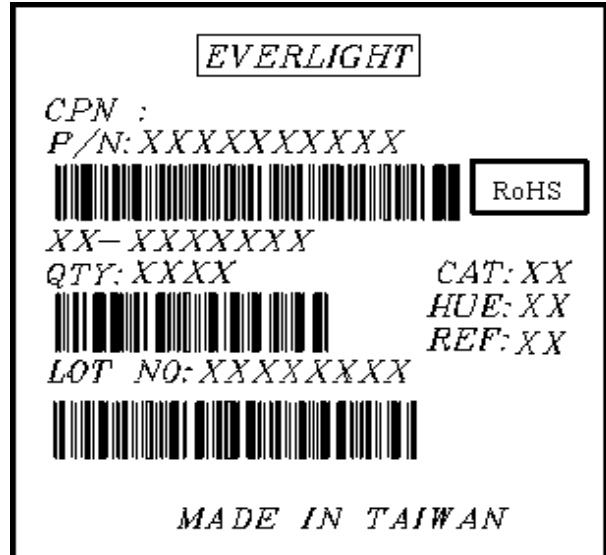

Reel Dimensions

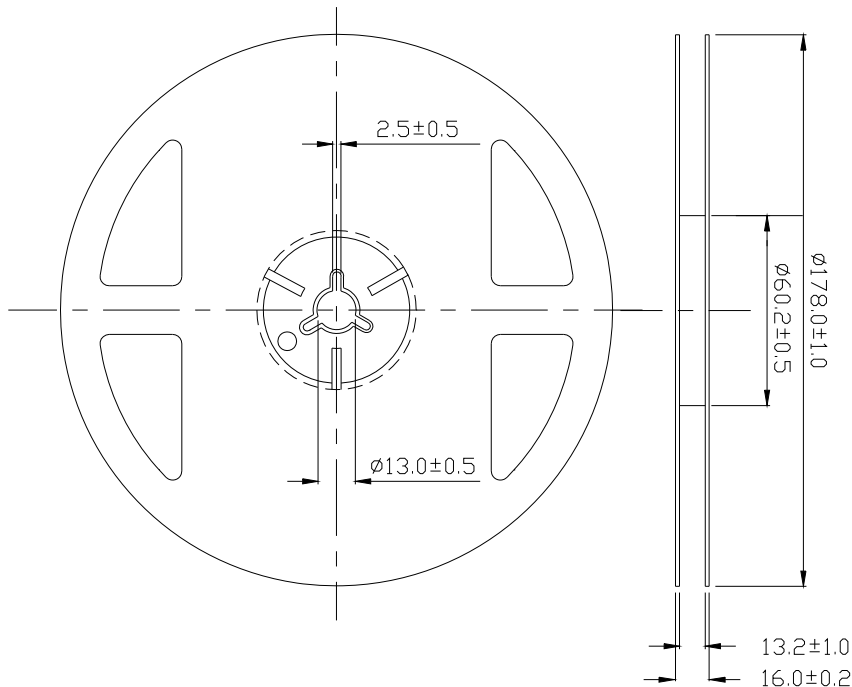

Note: Unit = mm

Technical Data Sheet

Top View LEDs

65-21-B3T-A0S1T1A7E-2T8-AM

Precautions for Use

1. Soldering Condition

1.1 (A) Maximum Body Case Temperature Profile for evaluation of Reflow Profile

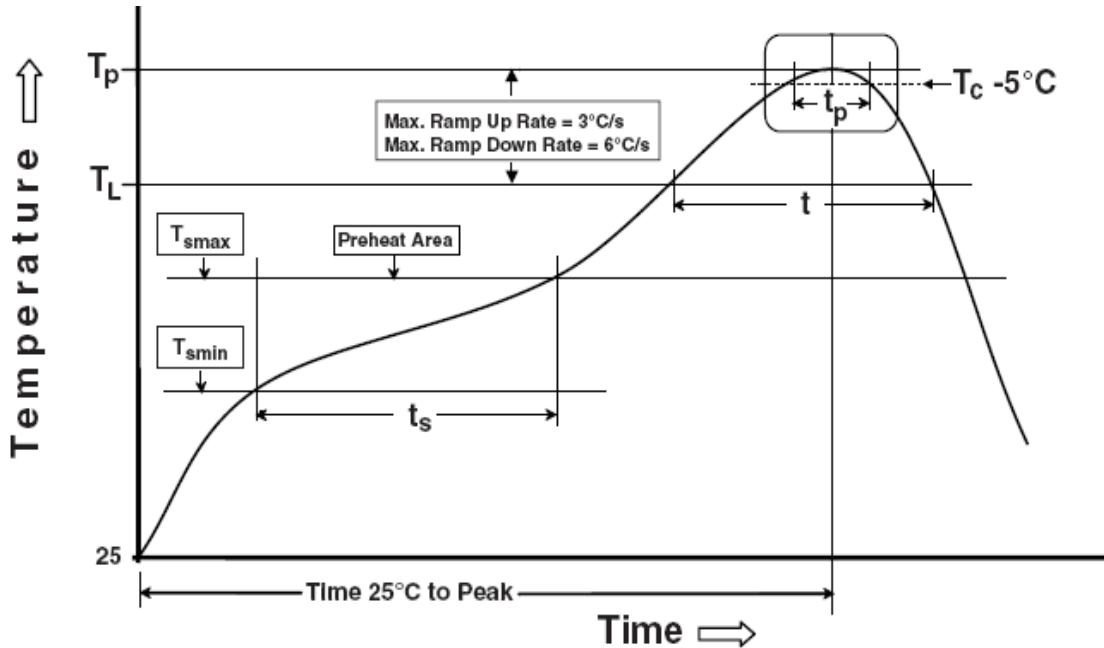

Note:

Preheat

Temperature min (T_{smin})

Temperature max (T_{smax})

Time (T_{smin} to T_{smax}) (t_s)

Average ramp-up rate (T_{smax} to T_p)

Other

Liquidus Temperature (T_L)

Time above Liquidus Temperature (t_L)

Peak Temperature (T_p)

Time within 5 °C of Actual Peak Temperature: $T_p - 5^\circ\text{C}$

Ramp- Down Rate from Peak Temperature

Time 25°C to peak temperature

Reflow times

Reference: IPC/JEDEC J-STD-020D

150 °C

200°C

60-120 seconds

3 °C/second max

217 °C

60-150 sec

260°C

30 s

6°C /second max.

8 minutes max.

3 times

All parameters are maximum body case temperature values and cannot be considered as a soldering profile. The body case temperature was measured by soldering a thermal couple to the soldering point of LEDs.

Technical Data Sheet**Top View LEDs****65-21-B3T-A0S1T1A7E-2T8-AM**

(B) Recommend soldering pad

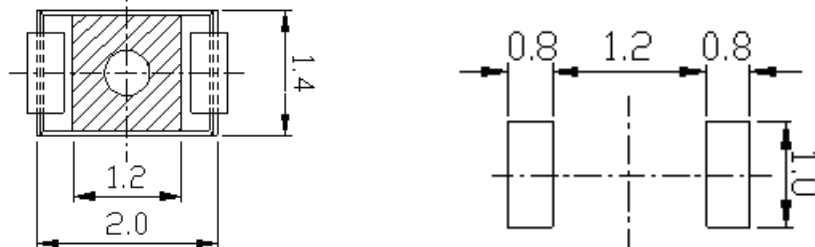

Note: Tolerances unless mentioned ± 0.1 mm. Unit = mm

2. Current limiting

A resistor should be used to limit current spikes that can be caused by voltage fluctuations. Otherwise damage could occur.

3. Storage

- 3.1 Moisture proof bag should only be opened immediately prior to usage.
- 3.2 Environment should be less than 30°C and 60% RH when moisture proof bag is opened.
- 3.3 After opening the package MSL Conditions stated on page 1 of this spec should not be exceeded.
- 3.4 If the moisture sensitivity card indicates higher than acceptable moisture, the component should be baked at min. 60deg +/-5deg for 24 hours.

4. Iron Soldering

Hand soldering is not recommended for regular production. These guidelines are for rework only. Soldering iron tip should contact each terminal no more than 3 sec at 350°C, using soldering iron with nominal power less than 25W. Allow min. 2 sec. between soldering intervals.

5. Usage

Do not exceed the values given in this specification.

Application Restrictions

High reliability applications such as military/aerospace, automotive safety/security systems, and medical equipment may require different product. If you have any concerns, please contact Everlight before using this product in your application. This specification guarantees the quality and performance of the product as an individual component. Do not use this product beyond the specification described in this document.