



Technical Data Sheet

Power LED

31-01/X5C-AQSC

Features

- . High Flux Output.
- . Designed for High Current Operation.
- . Low Thermal Resistance.
- . Low Profile.
- . Packaged in Tubes for Use with Automatic Insertion Equipment.
- . The product itself will remain within RoHS compliant version.



Descriptions

This revolutionary package design allows the light designer to reduce the number of LEDs required and provide a more uniform and unique illuminated appearance than with other LED solutions. This is possible through the efficient optical package design and high-current capabilities.

The low profile package can be easily coupled with reflectors or lenses to efficiently distribute light and provide the desired light appearance.

Applications

- . Automotive Lighting
- . Electronic Signs and Signals
- . Special Lighting application

Device Selection Guide

PART NO.	Chip		Lens Color
	Material	Emitted Color	
31-01/Y5C-AQSC	AlGaInP	Super Yellow	Water Clear
31-01/A5C-AQSC		Super Sunset Orange	
31-01/R5C-AQSC		Hyper Red	



Technical Data Sheet

Power LED

31-01/X5C-AQSC

Package Dimensions

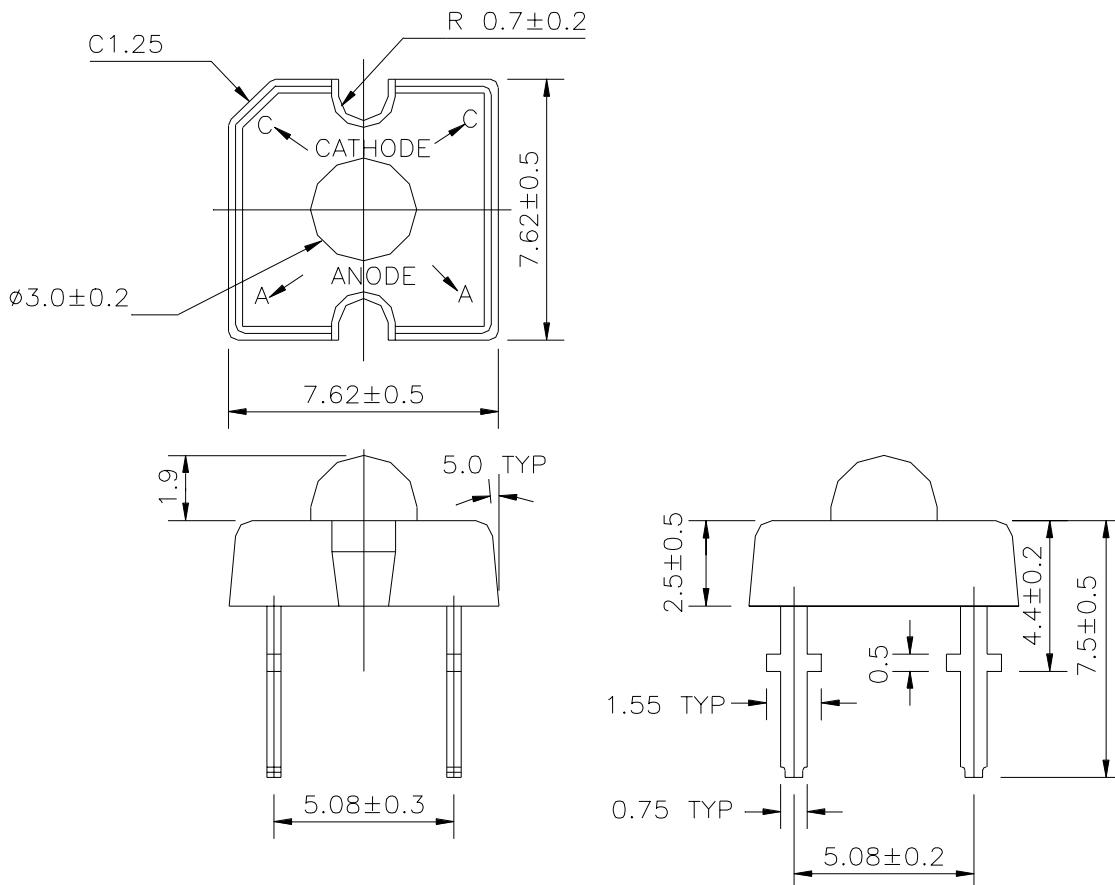

Notes: 1.All dimensions are in millimeters

2.An epoxy meniscus may extend about 1.5mm(0.059") down the leads

3.Tolerances unless dimensions ± 0.25 mm



Technical Data Sheet

Power LED

31-01/X5C-AQSC

Absolute Maximum Ratings

Parameter	Symbol	Rating	Units
Continuous Forward Current	I_F	70	mA
Peak Forward Current(Duty 1/10 @ 1KHZ)	I_{FP}	160	mA
Reverse Voltage	V_R	5	V
Operating Temperature	T_{opr}	-40 ~ +100	
Storage Temperature	T_{stg}	-40 ~ +100	
Soldering Temperature(T=5 sec)	T_{sol}	260 ± 5	
LED Junction Temperature	T_j	125	
Power Dissipation	P_d	220	mW
Electrostatic Discharge	ESD	2K	V

Electro-Optical Characteristics (Ta=25)

Parameter	Symbol	Part No.	Min.	Typ.	Max.	Condition	Unit
Total Flux	v	31-01/Y5C-AQSC	3600	4500	7150	$I_F=70mA$	mlm
		31-01/A5C-AQSC	3600	5100	7150	$I_F=70mA$	mlm
		31-01/R5C- AQSC	3600	4500	7150	$I_F=70mA$	mlm
Viewing Angle	2 1/2	31-01/X5C-AQSC	----	55	----	$I_F=70mA$	deg
Peak Wavelength	p	31-01/Y5C-AQSC	----	591	----	$I_F=20mA$	nm
		31-01/A5C-AQSC	----	621	----		
		31-01/R5C- AQSC	----	632	----		
Dominant Wavelength	d	31-01/Y5C-AQSC	----	589	----	$I_F=20mA$	nm
		31-01/A5C-AQSC	----	615	----		
		31-01/R5C- AQSC	----	624	----		
Spectrum Radiation Bandwidth		31-01/Y5C-AQSC	----	15	----	$I_F=20mA$	nm
		31-01/A5C-AQSC	----	18	----		
		31-01/R5C- AQSC	----	20	----		
Forward Voltage	VF	31-01/X5C-AQSC	2.1	2.6	3.1	$I_F=70mA$	V
Reverse Current	IR	31-01/X5C-AQSC	----	----	10	$V_R=5V$	uA



Technical Data Sheet

Power LED

31-01/X5C-AQSC

Rank

(1) (2) (3)

(1) Vf(V)			(31-01/Y5C) (2) d(nm)			(3) v(mlm)		
Bin	Min	Max	Bin	Min	Max	Bin	Min	Max
3	2.10	2.30	1	586	590	Q	3600	4500
4	2.30	2.50	2	590	594	R	4500	5650
5	2.50	2.70	3	594	598	S	5650	7150
6	2.70	2.90	(31-01/A5C) (2) d(nm)					
7	2.90	3.10	6	613.5	617			
			7	617	620			
			(31-01/R5C) (2) d(nm)					
			2	620	624			
			3	624	628			

*Measurement Uncertainty of Forward Voltage : $\pm 0.1V$

*Measurement Uncertainty of Luminous Intensity: $\pm 15\%$

*Measurement Uncertainty of Dominant Wavelength $\pm 1.0nm$



Technical Data Sheet

Power LED

31-01/X5C-AQSC

Typical Electro-Optical Characteristics Curves

Relative Intensity vs. Wavelength

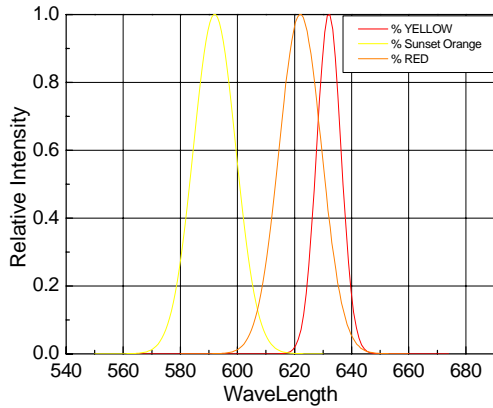

Forward Current vs. Forward Voltage

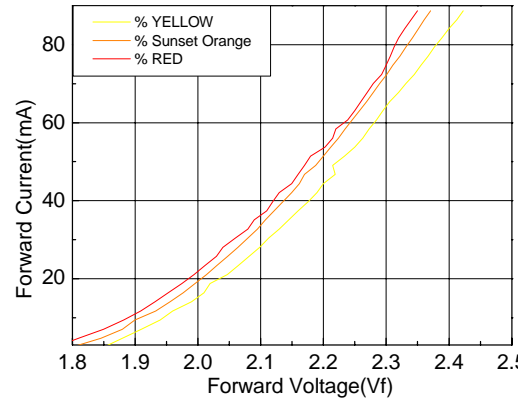

Relative Intensity vs. Forward Current

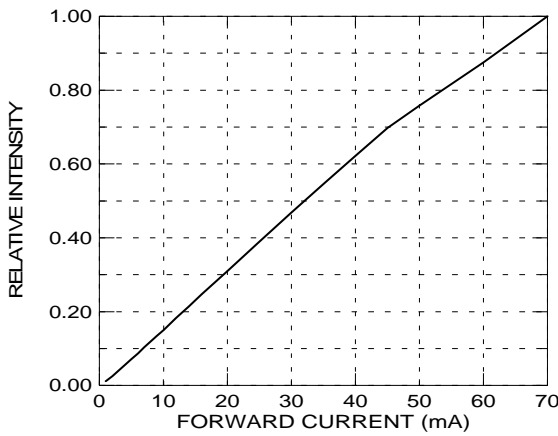

Forward Current vs. Ambient Temp.

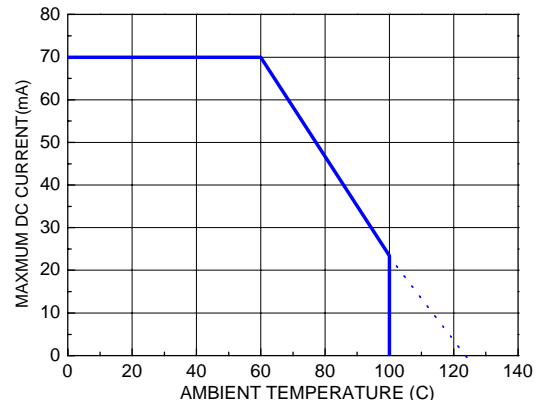

Relative Intensity vs. Angle Displacement

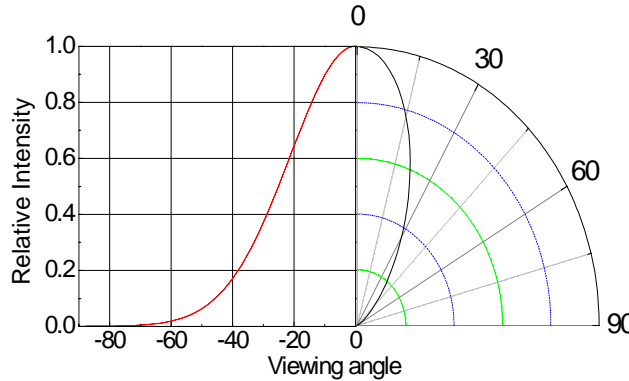



Technical Data Sheet

Power LED

31-01/X5C-AQSC

Packing Quantity Specification

- (1) 60 pcs/1 tube, 30 tubes/1 small inside box, 12 small inside boxes/1 outside box.
- (2) 60 pcs/1 tube, 105 tubes/1 big inside box, 8 big inside boxes/1 outside box.

Label Form Specification

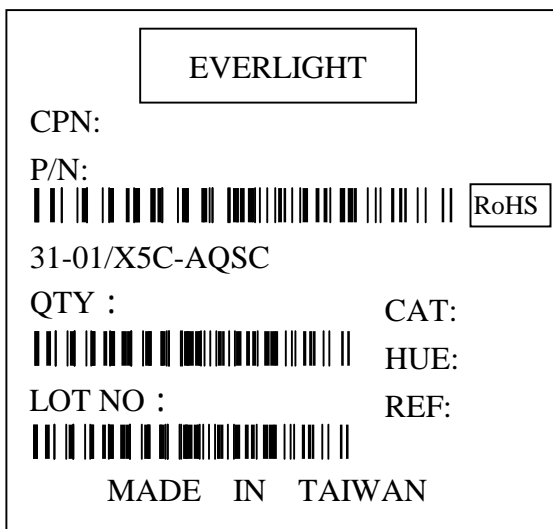

- CPN: Customer's Production Number
- P/N : Production Number
- QTY: Packing Quantity
- CAT: Ranks of Total Flux and Forward Voltage
- HUE: Rank of Dominant Wavelength
- REF: Reference
- LOT No: Lot Number
- MADE IN TAIWAN: Production Place



Technical Data Sheet

Power LED

31-01/X5C-AQSC

Notes

1. Above specification may be changed without notice. EVERLIGHT will reserve authority on material change for above specification.
2. When using this product, please observe the absolute maximum ratings and the instructions for using outlined in these specification sheets. EVERLIGHT assumes no responsibility for any damage resulting from use of the product which does not comply with the absolute maximum ratings and the instructions included in these specification sheets.
3. These specification sheets include materials protected under copyright of EVERLIGHT corporation. Please don't reproduce or cause anyone to reproduce them without EVERLIGHT's consent.
4. Soldering Condition

Careful attention should be paid during soldering. When soldering, leave more than 3mm from solder joint to case, and soldering beyond the base of the tie bar is recommended.

Avoiding applying any stress to the lead frame while the LEDs are at high temperature particularly when soldering.

Recommended soldering conditions:

Hand Soldering		DIP Soldering	
Temp. at tip of iron	400 Max. (30W Max.)	Preheat temp.	100 Max. (60 sec Max.)
Soldering time	3 sec Max.	Bath temp.	265 Max.
Distance	3mm Min.(From solder joint to case)	Bath time.	5 sec Max.
		Distance	3mm Min.

EVERLIGHT ELECTRONICS CO., LTD.
Office: No 25, Lane 76, Sec 3, Chung Yang Rd,
Tucheng, Taipei 236, Taiwan, R.O.C

Tel: 886-2-2267-2000, 2267-9936
Fax: 886-2267-6244, 2267-6189, 2267-6306
<http://www.everlight.com>