



EVERLIGHT ELECTRONICS CO.,LTD.

DATA SHEET

PART NO. : 12-215/BHC-ZLMRY/3C

DATE : 2003/4/21

DEPARTMENT : R.D.1

REVISION : 1.2

RECEIVED			
<input checked="" type="checkbox"/> MASS PRODUCTION			
<input type="checkbox"/> PRELIMINARY			
<input type="checkbox"/> CUSTOMER DESIGN			
DEVICE NUMBER : DSE-125-B01			
PAGE : 12			
CUSTOMER	DESIGNER	CHECKER	APPROVER
	Jeff Tasi	Charles Chang	

1.2	Update data	2003/4/21
-	DESCRIPTION	RELEASE DATE

OFFICE : NO 25,Lane 76,Chung Yang Rd,Sec.3 Tucheng, Taipei 236, Taiwan, R.O.C.

TEL : 886-2-2267-2000,2266-9936 (22 Lines)

FAX : 886-2-2267-6189

<http://www.everlight.com>

Package Type:

SMD For PCB Type

11-21	19-215
12-21	19-215A
12-215	19-217A
15-21	22-21
15-215	23-21
16-213	23-21B
17-21	24-21
17-215	25-21
19-21	27-21
19-21A	42-21

Dominant Wavelength Groups:

According to the difference wavelength to define

None: No definition

- A : Standard wavelength definition.
- B : Range of wavelength definition is more narrowly than group A.
- C : Range of wavelength definition is more narrowly than group A, but the value is different with group B.
- F : The wavelength definition in special specification.

The dominant wavelength data did not including ±1nm testing tolerance.

Test Forward Current:

- None: 20 mA
- Y : 5 mA
- Z : 10 mA

Taping Quantity:

- 1: 1000 pcs (Taping)
- 2: 2000 pcs (Taping)
- 3: 3000 pcs (Taping)
- 5: 5000 pcs (Taping)
- C : 1500 pcs (Taping)
- D : 10000 pcs (Taping)

Packing Method :

- A: Reverse-side placement (Anode toward the sprocket hole)
- B: Reverse-side placement (Anode toward the sprocket hole)
- C: Right-side placement
- D: Right-side placement (Anode toward the sprocket hole)
- T: Top-side placement
- R: Top-side placement (Anode toward the sprocket hole)

19 - 21

/

B

H

C

-

A

N1

P2

M

/

3

T

Emission Color:

R: Red

(λ d: 640nm, 630nm, 625nm)

S: Sunset Orange

(λ d: 615nm, 605nm)

Y: Yellow

(λ d: 595nm, 590nm)

G: Green

(λ d: 570nm, 565nm, 560nm, 525nm, 505nm)

B: Blue

(λ d: 470nm)

W: White x=0.32
y=0.31

The ordinal number that base on diffence electro-optical characteristics within chip.

1,2 7,8,9,
A,B.....X,Y,Z

Resin Color:

- C: Water Clear
- W: White Diffused
- D: Diffused

Luminous Intensity Groups:

- C0: 0.28 ... 0.45
- D0: 0.45 ... 0.70
- E0: 0.70 ... 1.1
- F0: 1.1 ... 1.8
- G0: 1.8 ... 2.8
- H0: 2.8 ... 4.5
- J0: 4.5 ... 7.2
- K0: 7.2 ... 11.5
- L ⇒ L1: 11.5 ... 14.5
- L2: 14.5 ... 18.0
- M ⇒ M1: 18.0 ... 22.5
- M2: 22.5 ... 28.5
- N ⇒ N1: 28.5 ... 36.0
- N2: 36.0 ... 45.0
- P ⇒ P1: 45.0 ... 57.0
- P2: 57.0 ... 72.0
- Q ⇒ Q1: 72.0 ... 90.0
- Q2: 90.0 ... 112

- R ⇒ R1: 112 ... 140
- R2: 140 ... 180
- S ⇒ S1: 180 ... 225
- S2: 225 ... 285
- T ⇒ T1: 285 ... 360
- T2: 360 ... 450
- U ⇒ U1: 450 ... 565
- U2: 565 ... 715
- V ⇒ V1: 715 ... 900
- V2: 900 ... 1120
- W ⇒ W1: 1120 ... 1420
- W2: 1420 ... 1800
- X ⇒ X1: 1800 ... 2250
- X2: 2250 ... 2850
- Y ⇒ Y1: 2850 ... 3600
- Y2: 3600 ... 4500

Unit: mcd

The luminous intensity data did not including ±15% testing tolerance.

Forward Voltage Groups:

None: No definition

The VF definition as follows:

Forward Voltage Group	Bin	Unit: V	
		Min.	Max.
C	00	1.55	1.75
	0	1.75	1.95
	1	1.95	2.15
	2	2.15	2.35
	3	2.35	2.55
M	4	2.55	2.75
	5	2.75	3.05
	6	3.05	3.35
	7	3.35	3.65
	8	3.65	3.95
N	9	2.50	2.70
	10	2.70	2.90
	11	2.90	3.10
	12	3.10	3.30
	13	3.30	3.50
P	14	3.50	3.70
	15	2.70	2.85
	16	2.85	3.00
	17	3.00	3.15
	18	3.15	3.30

The forward voltage data did not including ±0.1V testing tolerance.

ANNEX



EVERLIGHT ELECTRONICS CO., LTD.

REV.: 1.3

PAGE: 1/1

■ Dominant Wavelength Groups:

B1				
Dom . Wavelength	Range			
Of Group	Bin	Min.	Max.	Unit
A	A7	458.5	461.5	nm
	A8	461.5	464.5	nm
	A9	464.5	467.5	nm
	A10	467.5	470.5	nm
	A11	470.5	473.5	nm
	A12	473.5	476.5	nm

B3				
Dom . Wavelength	Range			
Of Group	Bin	Min.	Max.	Unit
A	A8	461.5	464.5	nm
	A9	464.5	467.5	nm
	A10	467.5	470.5	nm
	A11	470.5	473.5	nm
	A12	473.5	476.5	nm
	A13	476.5	479.5	nm

BL				
Dom . Wavelength	Range			
Of Group	Bin	Min.	Max.	Unit
A	A5	452.5	455.5	nm
	A6	455.5	458.5	nm
	A7	458.5	461.5	nm
	A8	461.5	464.5	nm
	A9	464.5	467.5	nm

BH						
Dom . Wavelength			Range			
Of Groups			Bin	Min.	Max.	Unit
A	B	A9	464.5	467.5	nm	
		A10	467.5	470.5	nm	
	C	A11	470.5	473.5	nm	
		A12	473.5	476.5	nm	
V	Z	X	465	470	nm	
		Y	470	475	nm	
	W	475	480	nm		

■ Forward Voltage Groups:

Forward Voltage Groups				Range																																																						
				Bin	Min.	Max.	Unit																																																			
<table border="1" style="width:100%; height:100%; border-collapse: collapse;"> <tr><td colspan="4" style="background-color: #cccccc;"></td></tr> <tr><td colspan="3" style="background-color: #cccccc;"></td><td style="text-align: center;">A</td></tr> <tr><td colspan="2" style="background-color: #cccccc;"></td><td style="text-align: center;">B</td><td style="background-color: #cccccc;"></td></tr> <tr><td colspan="2" style="background-color: #cccccc;"></td><td style="text-align: center;">C</td><td style="background-color: #cccccc;"></td></tr> <tr><td colspan="4" style="background-color: #cccccc;"></td></tr> <tr><td colspan="2" style="background-color: #cccccc;"></td><td style="text-align: center;">E</td><td style="text-align: center;">D</td></tr> <tr><td colspan="2" style="background-color: #cccccc;"></td><td style="text-align: center;">M</td><td style="background-color: #cccccc;"></td></tr> <tr><td colspan="4" style="background-color: #cccccc;"></td></tr> <tr><td colspan="3" style="background-color: #cccccc;"></td><td style="text-align: center;">R</td><td style="text-align: center;">J</td></tr> <tr><td style="text-align: center;">N</td><td style="text-align: center;">F</td><td style="text-align: center;">K</td><td style="background-color: #cccccc;"></td></tr> <tr><td colspan="4" style="background-color: #cccccc;"></td></tr> <tr><td colspan="3" style="background-color: #cccccc;"></td><td style="text-align: center;">P</td><td style="text-align: center;">H</td></tr> <tr><td colspan="4" style="background-color: #cccccc;"></td></tr> </table>								A			B				C								E	D			M									R	J	N	F	K									P	H					00	1.55	1.75	v
				A																																																						
			B																																																							
			C																																																							
			E	D																																																						
			M																																																							
				R	J																																																					
	N	F	K																																																							
				P	H																																																					
		0	1.75	1.95	v																																																					
		1	1.95	2.15	v																																																					
		2	2.15	2.35	v																																																					
		3	2.35	2.55	v																																																					
	4	2.55	2.75	v																																																						
	5	2.75	3.05	v																																																						
	6	3.05	3.35	v																																																						
	7	3.35	3.65	v																																																						
	8	3.65	3.95	v																																																						
	9	2.50	2.70	v																																																						
	10	2.70	2.90	v																																																						
	11	2.90	3.10	v																																																						
	12	3.10	3.30	v																																																						
	13	3.30	3.50	v																																																						
	14	3.50	3.70	v																																																						
	15	2.70	2.85	v																																																						
	16	2.85	3.00	v																																																						
	17	3.00	3.15	v																																																						
	18	3.15	3.30	v																																																						

Technical Data Sheet

Chip LED with Right Angle Lens

12-215/B__C Series *1

Features

- Package in 8mm tape on 7" diameter reel.
- Compatible with automatic placement equipment.
- Compatible with infrared and vapor phase reflow solder process.
- Mono-color type.

Descriptions

- The 12-215 SMD Taping is much smaller than lead frame type components, thus enable smaller board size, higher packing density, reduced storage space and finally smaller equipment to be obtained.
- Besides, lightweight makes them ideal for miniature applications. etc.

Applications

- Automotive: backlighting in dashboard and switch.
- Telecommunication: indicator and backlighting in telephone and fax.
- Flat backlight for LCD, switch and symbol.
- General use.



Device Selection Guide

Part No.	Chip		Lens Color
	Material	Emitted Color	
12-215/B1C	GaN/SiC	Purplish Blue	Water Clear
12-215/B3C	InGaN/SiC	Blue	
12-215/BLC	InGaN	Deep-Blue	
12-215/BHC		Blue *2	

*1. The series is included 12-215/B1C,12-215/B3C,12-215/BLC, and 12-215/BHC.

*2. Emitted color is distinguished to Dark Blue and Brilliant Blue.

Package Outline Dimensions

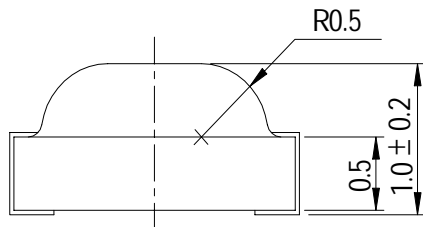
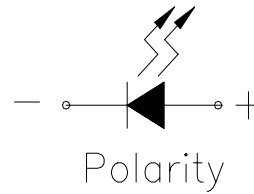
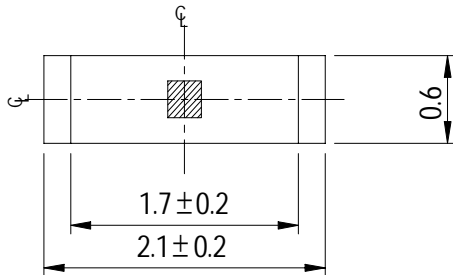

For reflow soldering (Propose)

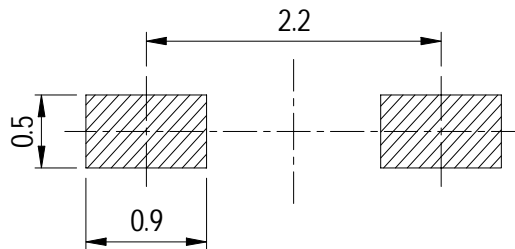
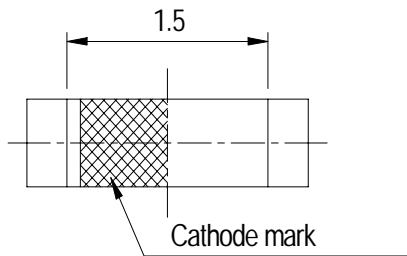

Note: The tolerances unless mentioned is $\pm 0.1\text{mm}$, Angle $\pm 0.5^\circ$,Unit = mm

Absolute Maximum Ratings (Ta=25°C)

Series	Parameter	Symbol	Rating	Unit
12-215/B_C Series	Reverse Voltage	V _R	5	V
12-215/B_C Series	Forward Current	I _F	25	mA
12-215/B1C/B3C			30	
12-215/B_C Series	Operating Temperature	T _{opr}	-40 ~ +85	°C
12-215/B_C Series	Storage Temperature	T _{stg}	-40 ~ +90	°C
12-215/B_C Series	Soldering Temperature	T _{sol}	260 (for 5 seconds)	°C
12-215/B_C Series	Electrostatic Discharge	ESD	150	V
12-215/B1C/B3C			1000	
12-215/B_C Series	Power Dissipation	P _d	110	mW
12-215/B1C/B3C			130	
12-215/B_C Series	Peak Forward Current (Duty 1/10 @1KHz)	I _F	100	mA
12-215/B1C			70	

Electro-Optical Characteristics (Ta=25°C)

Part No.	Parameter	Symbol	Min.	Typ.	Max.	Unit	Condition
12-215/B1C	Peak Wavelength	λ_p	----	428	----	nm	If=20mA
12-215/B3C				468			
12-215/BLC				465			
12-215/BHC				468			
12-215/B1C	Dominant Wavelength	λ_d	----	466	----	nm	
12-215/B3C				470			
12-215/BLC				460			
12-215/BHC				470			
12-215/B1C	Spectrum Radiation Bandwidth	$\Delta \lambda$	----	65	----	nm	
12-215/B3C				26			
12-215/BLC				25			
12-215/BHC				25			
12-215/B_C Series	Viewing Angle	$2\theta_{1/2}$	----	130	----	deg	
12-215/B_C Series	Forward Voltage	V_F	----	3.5	4.0	V	
12-215/B1C				3.8	4.5		
12-215/B_C Series	Reverse Current	I_R	----	----	50	μA	$V_R=5V$

Notes:
1. Tolerance of Forward Voltage $\pm 0.1V$

■ 12-215/B__C Series Explain Of Luminous Intensity:
I_F=20mA

Part No.	Parameter	Symbol	Typ.	Bin Code	Min.	Max.	Unit
12-215/B1C-M1N2	Luminous Intensity	I _v	28	M1	18.0	22.5	mcd
				M2	22.5	28.5	
				N1	28.5	36.0	
				N2	36.0	45.0	
12-215/B3C-M1N2	Luminous Intensity	I _v	26	M1	18.0	22.5	mcd
				M2	22.5	28.5	
				N1	28.5	36.0	
				N2	36.0	45.0	
12-215/BLC-L2N1	Luminous Intensity	I _v	20	L2	14.5	18.0	mcd
				M1	18.0	22.5	
				M2	22.5	28.5	
				N1	28.5	36.0	
12-215/BHC-N1P2	Luminous Intensity	I _v	40	N1	28.5	36.0	mcd
				N2	36.0	45.0	
				P1	45.0	57.0	
				P2	57.0	72.0	
12-215/BHC-N2P2	Luminous Intensity	I _v	55	N2	36.0	45.0	mcd
				P1	45.0	57.0	
				P2	57.0	72.0	

Note:

 The luminous intensity data did not including $\pm 15\%$ testing tolerance.

■ 12-215/B__C Series Explain Of Luminous Intensity:
I_F=10mA

Part No.	Parameter	Symbol	Typ.	Bin Code	Min.	Max.	Unit
12-215/BHC-LN	Luminous Intensity	I _v	22	L	11.5	18.0	mcd
				M	18.0	28.5	
				N	28.5	45.0	
12-215/BHC-MN	Luminous Intensity	I _v	30	M	18.0	28.5	mcd
				N	28.5	45.0	

I_F=5mA

Part No.	Parameter	Symbol	Typ.	Bin Code	Min.	Max.	Unit
12-215/BHC-K0M	Luminous Intensity	I _v	12	K0	7.2	11.5	mcd
				L	11.5	18.0	
				M	18.0	28.5	
12-215/BHC-LM	Luminous Intensity	I _v	17	L	11.5	18.0	mcd
				M	18.0	28.5	

Note:

The luminous intensity data did not including $\pm 15\%$ testing tolerance.

Typical Electro-Optical Characteristics Curves

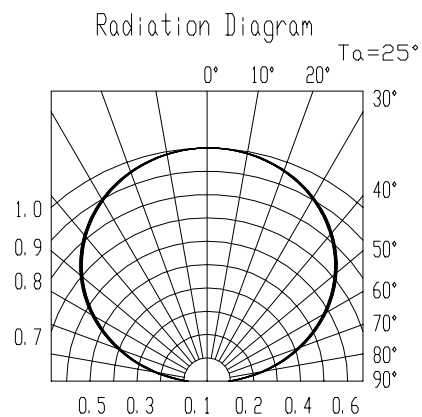
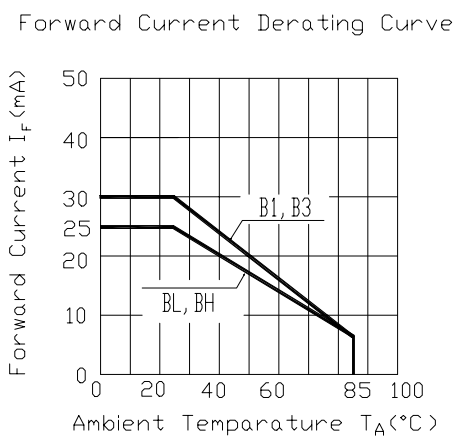
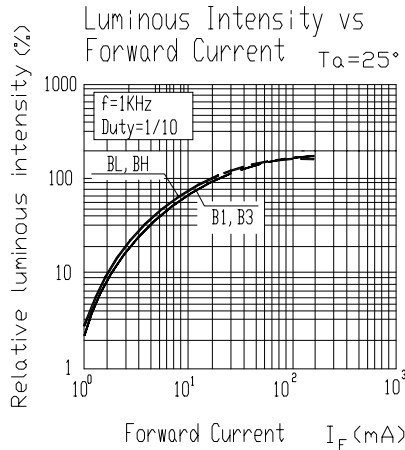
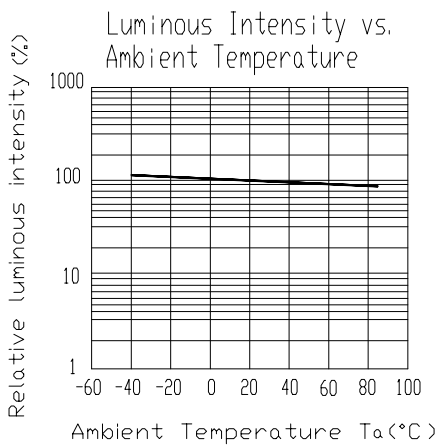
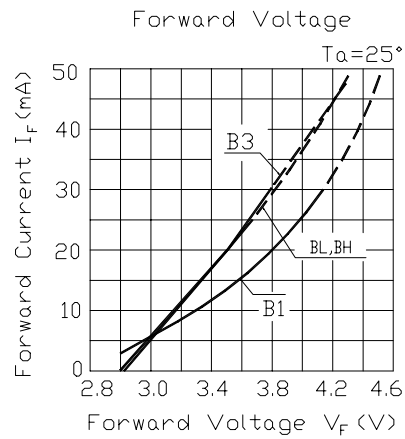
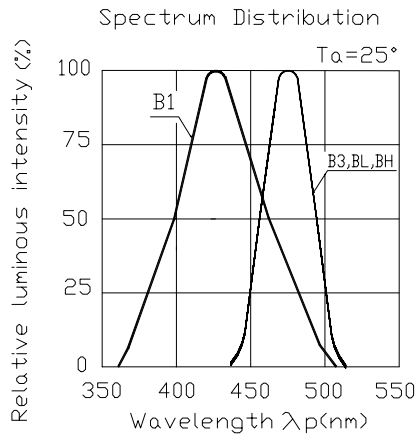

Label explanation

CAT: Luminous Intensity (mcd)

HUE: Dom. Wavelength (nm)

REF: Forward Voltage (V)

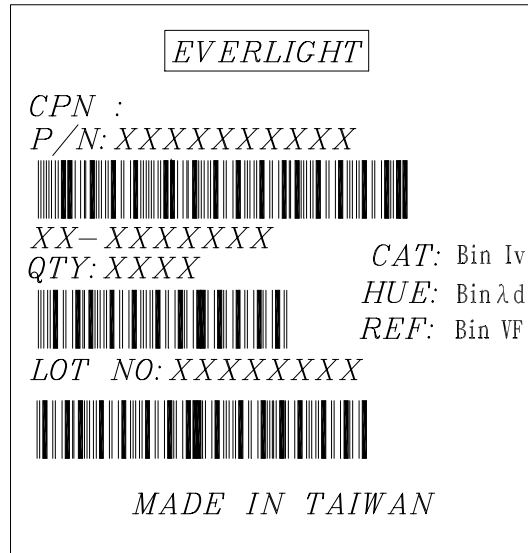

Reel Dimensions

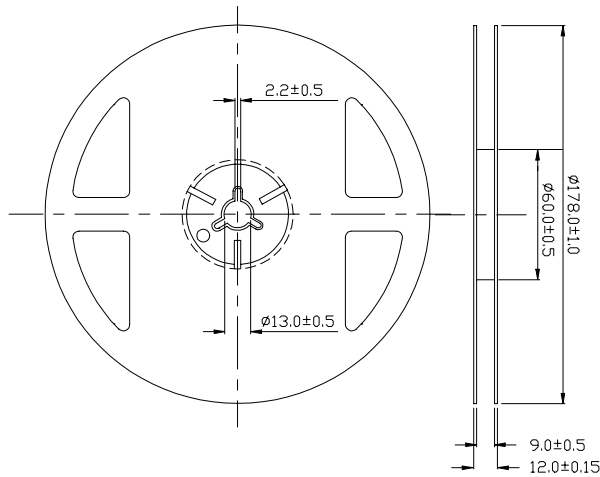

Taping Quantity: 3000pcs

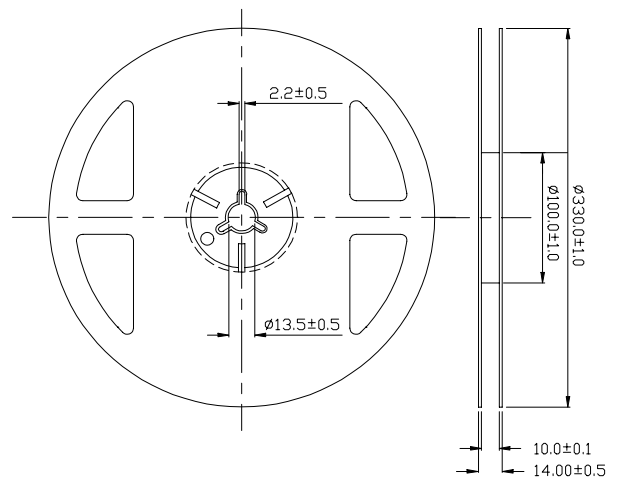

Taping Quantity: 5000pcs & 10000pcs

Note: The tolerances unless mentioned is $\pm 0.1\text{mm}$, Angle $\pm 0.5^\circ$,Unit = mm

Carrier Tape Dimensions

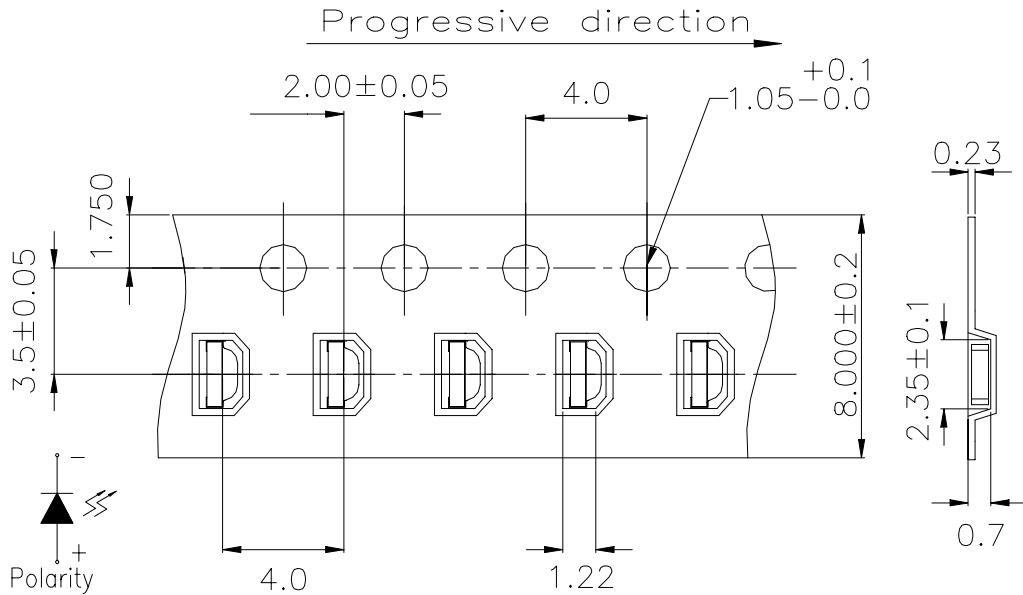

Note: Tolerances Unless Dimension $\pm 0.1\text{mm}$, Angle $\pm 0.5^\circ$,Unit = mm

Moisture Resistant Packaging

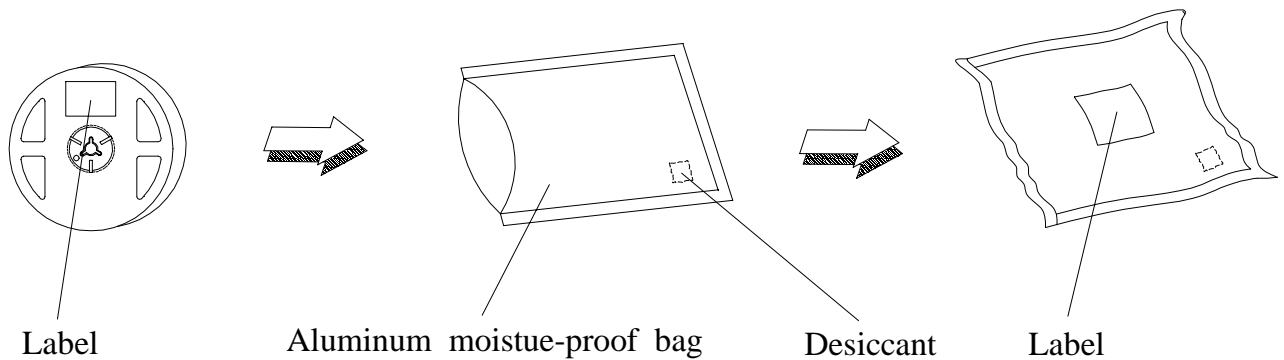

Reliability Test Items And Conditions

The reliability of products shall be satisfied with items listed below.

Confidence level : 90 %

LTPD : 10 %

No.	Items	Test Condition	Test Hours/Cycles	Sample Size	Ac/Rc
1	Reflow	Temp. : 240°C ± 5°C Min. 5 sec.	6 min.	22 Pcs.	0/1
2	Temperature Cycle	H : +100°C 15 min. § 5 min. L : -40°C 15 min.	300 Cycles	22 Pcs.	0/1
3	Thermal Shock	H : +100°C 5 min. § 10 sec. L : -10°C 5 min.	300 Cycles	22 Pcs.	0/1
4	High Temperature Storage	Temp. : 100°C	1000 Hrs.	22 Pcs.	0/1
5	Low Temperature Storage	Temp. : -55°C	1000 Hrs.	22 Pcs.	0/1
6	DC Operating Life	IF = 20 mA	1000 Hrs.	22 Pcs.	0/1
7	High Temperature / High Humidity	85°C/RH 85%	1000 Hrs.	22 Pcs.	0/1

Precautions For Use

1. Over-current-proof

Customer must apply resistors for protection , otherwise slight voltage shift will cause big current change (Burn out will happen).

2. Storage time

2.1 The operation of Temperature and RH are : 5°C ~35°C , RH60%.

2.2 Once the package is opened, the products should be used within a week.

Otherwise, they should be kept in a damp proof box with desiccating agent.

Considering the tape life , we suggest our customers to use our products within a year(from production date).

2.3 If opened more than one week in an atmosphere 5°C ~35°C , RH 60% , they should be treated at 60°C ± 5°C for 15hrs.

2.4 When you discover that the desiccant in the package has a pink color (Normal = blue) , you should treat them in the same conditions as 2.3.

Soldering heat

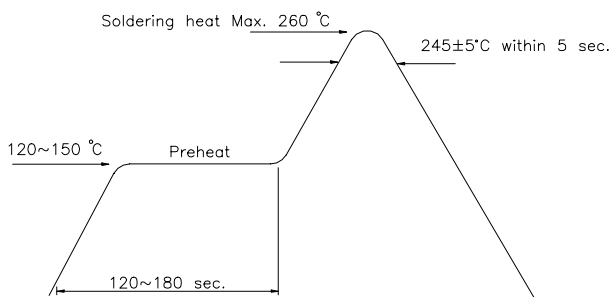

Reflow Temp / Time

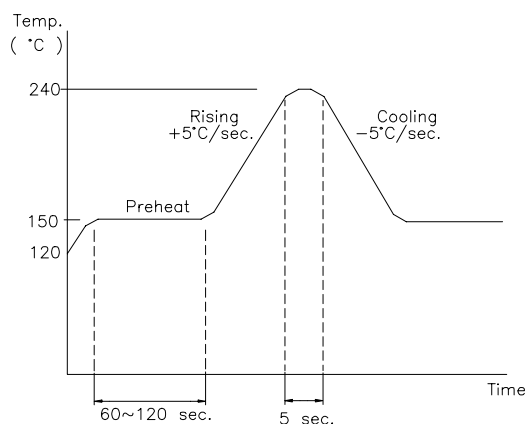

Soldering Iron

Basic spec is ≤ 5 sec when 260°C. If temperature is higher, time should be shorter (+10°C → -1sec).

Power dissipation of Iron should be smaller than 15 W , and temperature should be controllable.

Surface temperature of the device should be under 230 °C .

Rework

1. Customer must finish rework within 5 sec under 245°C.
2. The head of iron can not touch copper foil.
3. Twin-head type is preferred.

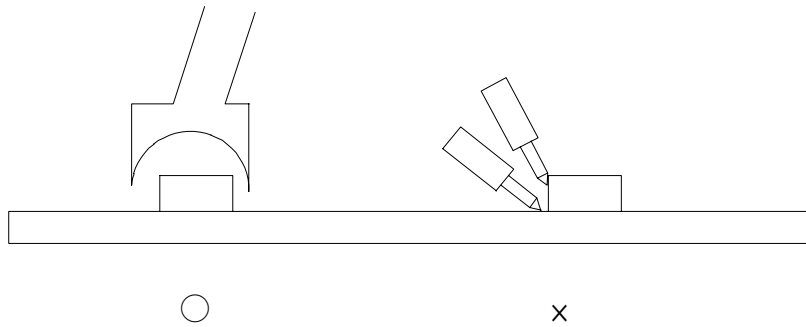

EVERLIGHT ELECTRONICS CO., LTD.
Office: No 25, Lane 76, Sec 3, Chung Yang Rd,
Tucheng, Taipei 236, Taiwan, R.O.C

Tel: 886-2-2267-2000, 2267-9936
Fax: 886-2267-6244, 2267-6189, 2267-6306
<http://www.everlight.com>