



Technical Data Sheet (Preliminary)

Side View White LEDs (0.8mm)

99-213UTC/S956/TR8

Features

- Side view white LED.
- White SMT package.
- Lead frame package with individual 2 pins.
- Wide viewing angle.
- Soldering methods: IR reflow soldering.
- ESD protection.
- Pb-free.
- The product itself will remain within RoHS compliant version.

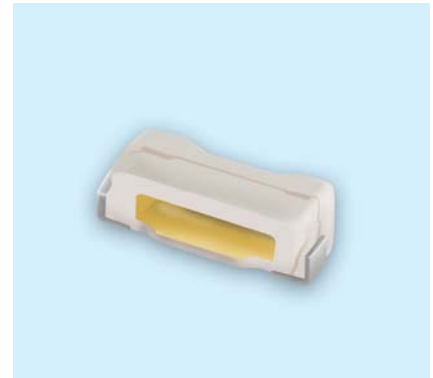

Descriptions

- Due to the package design, 99-113 has wide viewing angle , low power consumption and white LEDs are devices which are materialized by combing Blue LEDs and special phosphors . This feature makes the LED ideal for light guide application.

Applications

- LCD Back Light.
- Mobile phones .
- Indicators.
- Illuminations.
- Switch Lights.

Device Selection Guide

Chip		Lens Color
Material	Emitted Color	
InGaN	Pure White	Water Clear

Package Outline Dimensions

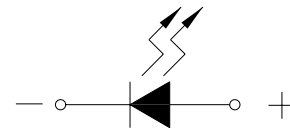
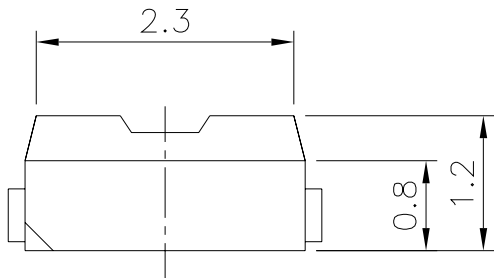

Polarity

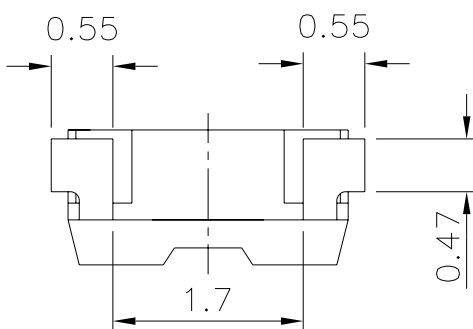
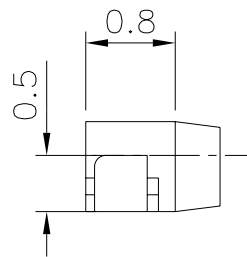
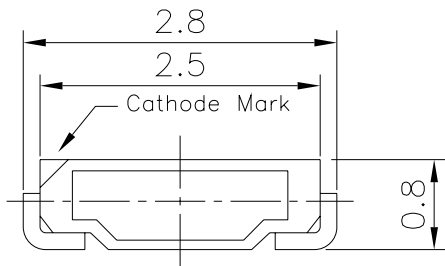

Recommended soldering pad design

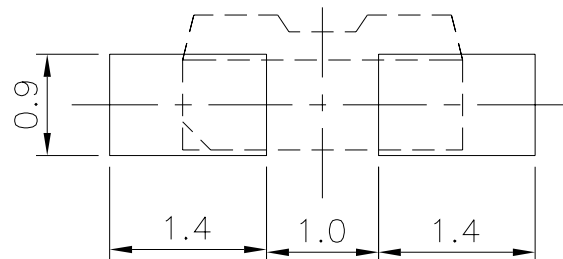

Notes: Tolerances Unless Dimension $\pm 0.1\text{mm}$, Unit = mm

Absolute Maximum Ratings (Ta=25°C)

Parameter	Symbol	Rating	Unit
Reverse Voltage	V _R	5	V
Forward Current	I _F	30	mA
Peak Forward Current (Duty 1/10 @10ms)	I _{FP}	100	mA
Power Dissipation	P _d	110	mW
Electrostatic Discharge(HUM)	ESD	1000	V
Operating Temperature	T _{opr}	-40 ~ +85	°C
Storage Temperature	T _{stg}	-40 ~ +90	°C
Soldering Temperature	T _{sol}	Reflow Soldering : 260 °C for 10 sec. Hand Soldering : 350 °C for 3 sec.	

Note: The products are sensitive to static electricity and care must be fully taken when handling products.

Electro-Optical Characteristics (Ta=25°C)

Parameter	Symbol	Min.	Typ.	Max.	Unit	Condition
Luminous Intensity	I _v	1250	-----	1800	mcd	I _F =20mA
Viewing Angle	2θ 1/2	-----	110	-----	deg	I _F =20mA
Forward Voltage	V	3.15	-----	3.55	V	I _F =20mA

Notes:

- 1.Tolerance of Luminous Intensity ±11%

99-213UTC/S956/TR8**Bin Range Of Luminous Intensity**

Bin Code	Min.	Max.	Unit	Conduction
23	1250	1300	mcd	I _F =20mA
24	1300	1350		
25	1350	1400		
26	1400	1450		
27	1450	1500		
28	1500	1550		
29	1550	1600		
30	1600	1650		
31	1650	1700		
32	1700	1750		
33	1750	1800		

Bin Range Of Forward Voltage

Bin Code	Min.	Max.	Unit	Conduction
7-1	3.15	3.25	V	I _F =20mA
7-2	3.25	3.35		
8-1	3.35	3.45		
8-2	3.45	3.55		
7-1	3.15	3.25		

Notes:

- 1.Tolerance of Luminous Intensity $\pm 11\%$
- 2.Tolerance of Forward Voltage $\pm 0.05V$

99-213UTC/S956/TR8

Chromaticity Coordinates Specifications for Bin Grading

I_F=20mA

Group	Bin Code	CIE_x	CIE_y	Bin Code	CIE_x	CIE_y	
2	1	B5-1	0.2915	0.2855	B5-3	0.2960	0.2760
			0.2870	0.2950		0.2915	0.2855
			0.2970	0.3050		0.3003	0.2950
			0.3003	0.2950		0.3035	0.2850
	1	B5-2	0.3003	0.2950	B5-4	0.3035	0.2850
			0.2970	0.3050		0.3003	0.2950
			0.3070	0.3150		0.3090	0.3045
			0.3090	0.3045		0.3110	0.2940
	2	A0-2	0.2818	0.2715	B6-1	0.3090	0.3045
			0.2755	0.2810		0.3070	0.3150
			0.2870	0.2950		0.3185	0.3270
			0.2915	0.2855		0.3195	0.3165
		A0-4	0.2879	0.2619	B6-3	0.3110	0.2940
			0.2818	0.2715		0.3090	0.3045
			0.2915	0.2855		0.3195	0.3165
			0.2960	0.2760		0.3205	0.3060

Group	Bin Code	CIE_x	CIE_y	Group	Bin Code	CIE_x	CIE_y
3	A0-1	0.2720	0.2575	4	B6-2	0.3195	0.3165
		0.2640	0.2670			0.3185	0.3270
		0.2755	0.2810			0.3300	0.3390
		0.2818	0.2715			0.3300	0.3285
	A0-3	0.2800	0.2480		B6-4	0.3205	0.3060
		0.2720	0.2575			0.3195	0.3165
		0.2818	0.2715			0.3300	0.3285
		0.2879	0.2619			0.3300	0.3180

Notes:

The C.I.E. 1931 chromaticity diagram (Tolerance ±0.01).

99-213UTC/S956/TR8

Chromaticity Coordinates Specifications for Bin Grading

$I_F=20mA$

Group	Bin Code	CIE_x	CIE_y	Bin Code	CIE_x	CIE_y	
7	B5-1	0.2915	0.2855	A0-4	0.2879	0.2619	
		0.2870	0.2950		0.2818	0.2715	
		0.2970	0.3050		0.2915	0.2855	
		0.3003	0.2950		0.2960	0.2760	
	B5-3	0.2960	0.2760	/			
		0.2915	0.2855				
		0.3003	0.2950				
		0.3035	0.2850				
8	A0-2	0.2818	0.2715	A0-3	0.2800	0.2480	
		0.2755	0.2810		0.2720	0.2575	
		0.2870	0.2950		0.2818	0.2715	
		0.2915	0.2855		0.2879	0.2619	
	A0-4	0.2879	0.2619	/			
		0.2818	0.2715				
		0.2915	0.2855				
		0.2960	0.2760				
9	A0-1	0.2720	0.2575	A0-B	0.2720	0.2575	
		0.2640	0.2670		0.2652	0.2429	
		0.2755	0.2810		0.2733	0.2333	
		0.2818	0.2715		0.2800	0.2480	
	A0-3	0.2800	0.2480	/			
		0.2720	0.2575				
		0.2818	0.2715				
		0.2879	0.2619				

Notes:

The C.I.E. 1931 chromaticity diagram (Tolerance ± 0.01).

Chromaticity Coordinates Specifications for Bin Grading

$I_F=20mA$

Group	Bin Code	CIE_x	CIE_y	Bin Code	CIE_x	CIE_y
A	A0-A	0.2640	0.2670	A0-C	0.2569	0.2528
		0.2569	0.2528		0.2498	0.2385
		0.2652	0.2429		0.2584	0.2283
		0.2720	0.2575		0.2652	0.2429
	A0-B	0.2720	0.2575	A0-D	0.2652	0.2429
		0.2652	0.2429		0.2584	0.2283
		0.2733	0.2333		0.2666	0.2185
		0.2800	0.2480		0.2733	0.2333
B	A0-3	0.2800	0.2480	A0-B	0.2720	0.2575
		0.2720	0.2575		0.2652	0.2429
		0.2818	0.2715		0.2733	0.2333
		0.2879	0.2619		0.2800	0.2480
	A0-4	0.2879	0.2619	/		
		0.2818	0.2715			
		0.2915	0.2855			
		0.2960	0.2760			
C	A0-1	0.2720	0.2575	A0-3	0.2800	0.2480
		0.2640	0.2670		0.2720	0.2575
		0.2755	0.2810		0.2818	0.2715
		0.2818	0.2715		0.2879	0.2619
	A0-2	0.2818	0.2715	A0-4	0.2879	0.2619
		0.2755	0.2810		0.2818	0.2715
		0.2870	0.2950		0.2915	0.2855
		0.2915	0.2855		0.2960	0.2760

Notes:

1. The C.I.E. 1931 chromaticity diagram (Tolerance ± 0.01).

*The C.I.E. 1931 chromaticity diagram (Tolerance ± 0.01).

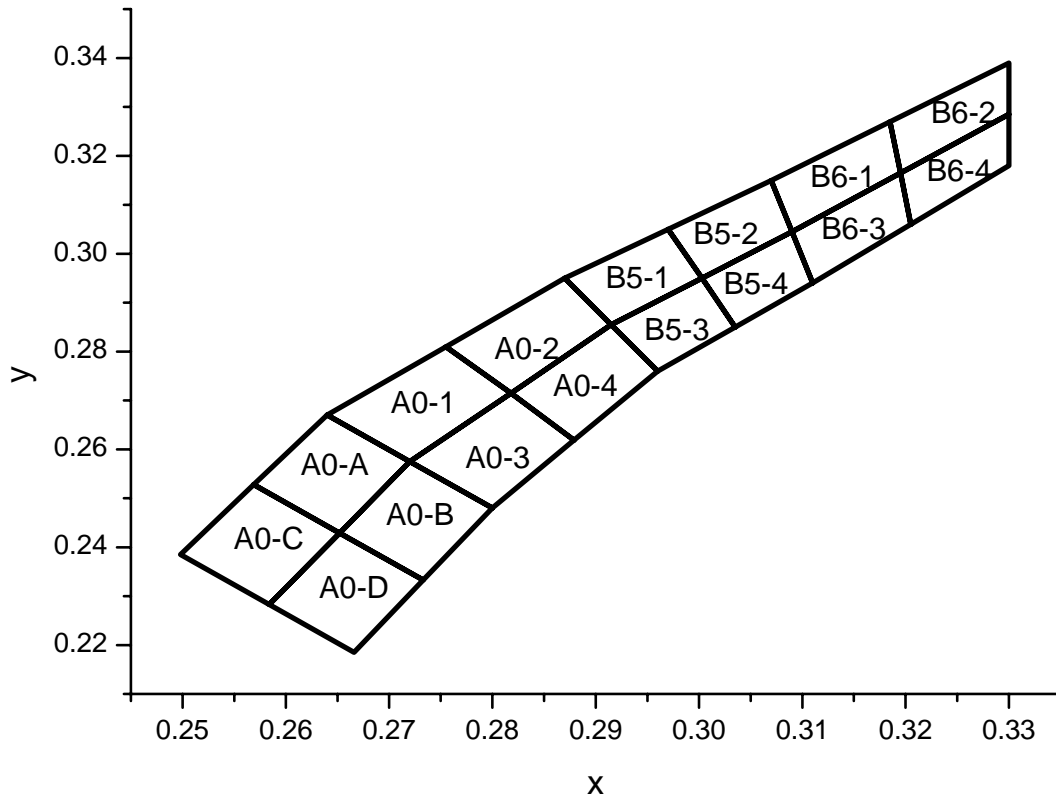

Typical Electro-Optical Characteristics Curves

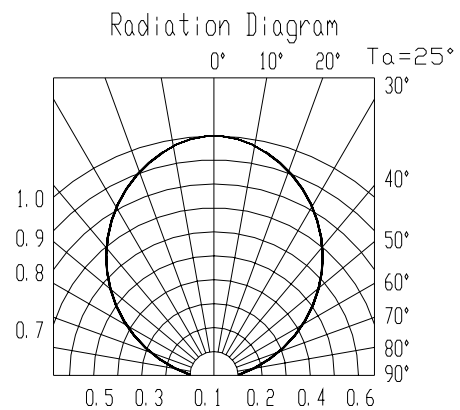
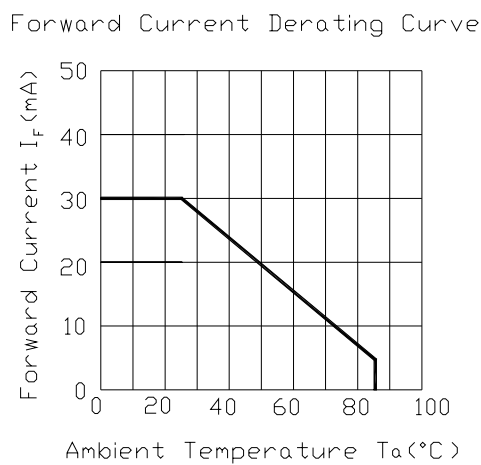
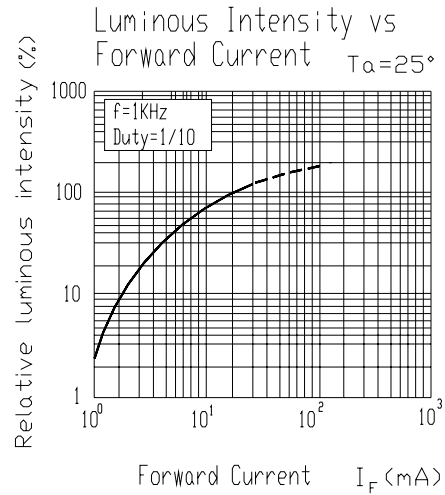
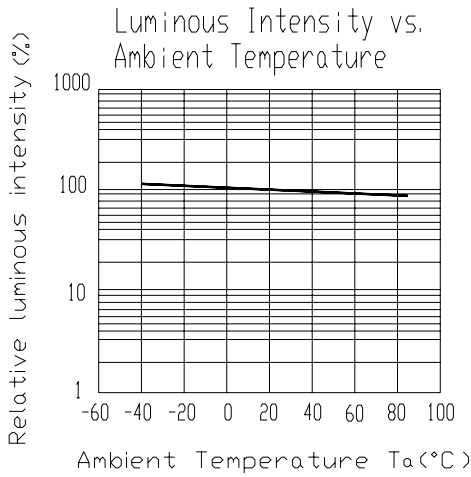
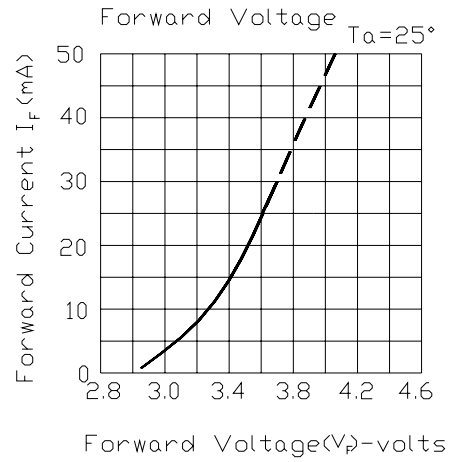
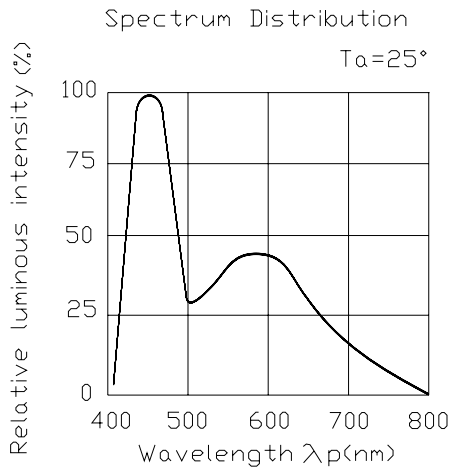

Label explanation

CAT: Luminous Intensity Rank

HUE: Chromaticity Coordinates

REF: Forward Voltage Rank

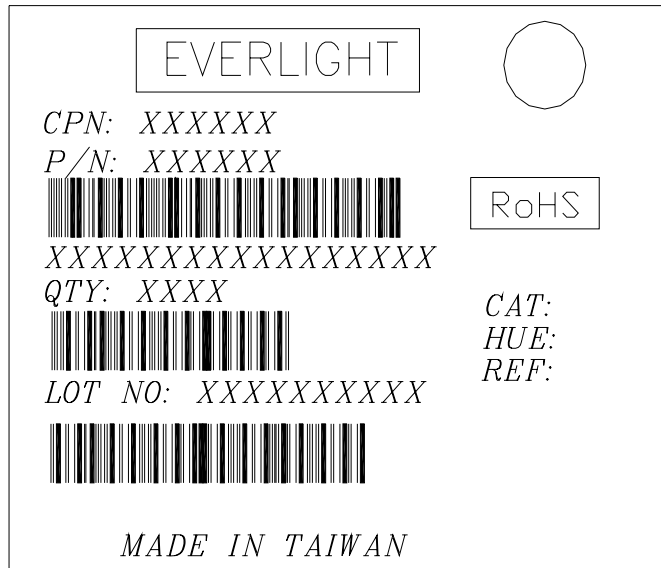

Reel Dimensions

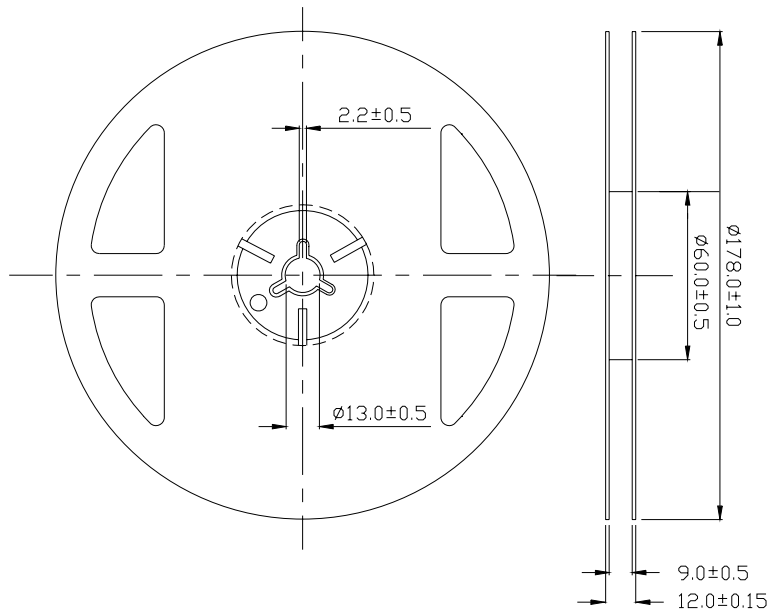

Note: The tolerances unless mentioned is ± 0.1 mm, Unit = mm

Carrier Tape Dimensions; Loaded quantity per reel 2000 PCS/reel

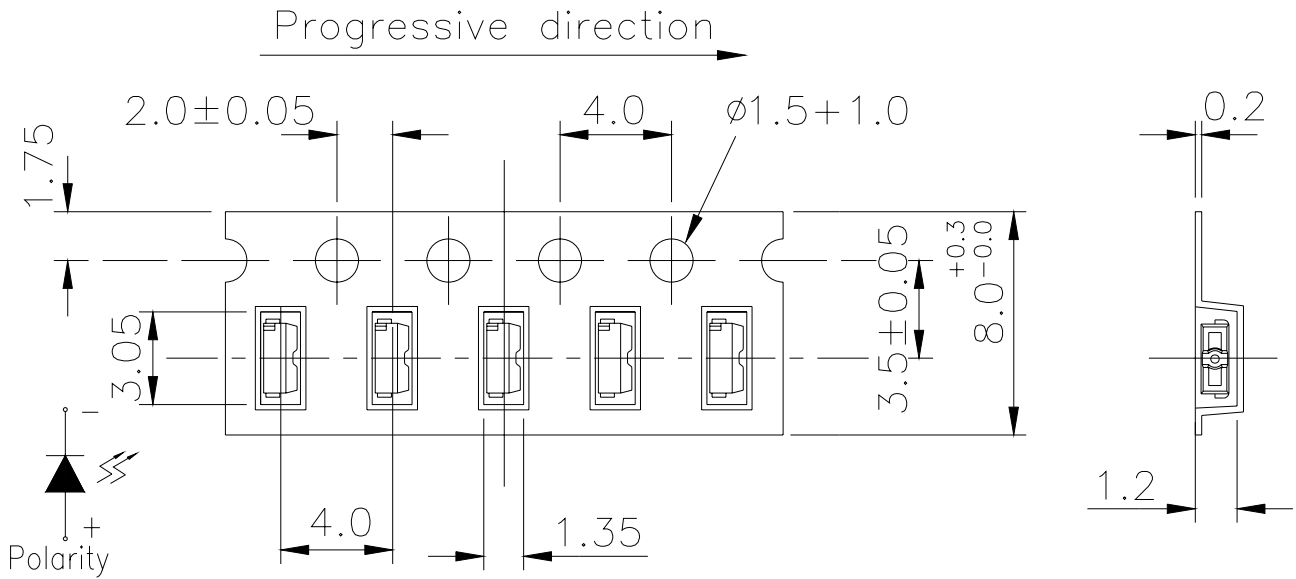

Note: Tolerances Unless Dimension ±0.1mm Unit = mm

Moisture Resistant Packaging

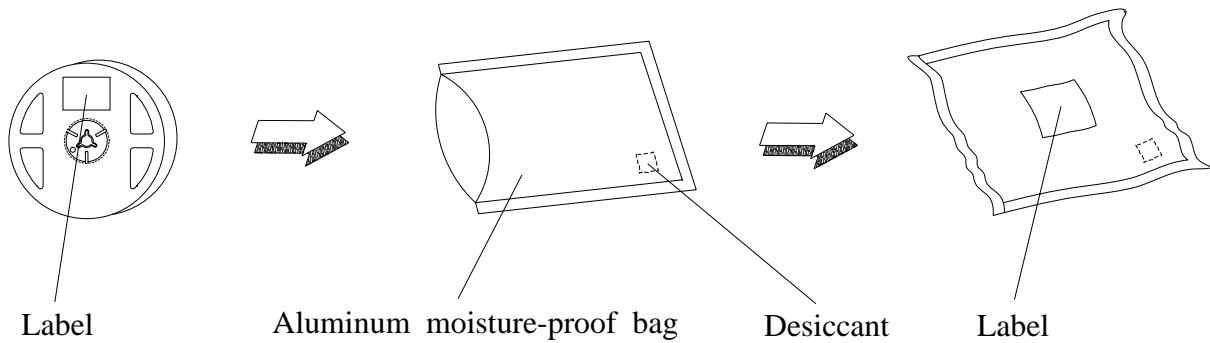

Reliability Test Items And Conditions

The reliability of products shall be satisfied with items listed below.

Confidence level : 90%

LTPD : 10%

No.	Items	Test Condition	Test Hours/Cycles	Sample Size	Ac/Re
1	Reflow Soldering	Temp. : 260°C±5°C Min. 5 sec.	6 Min.	22 PCS	0/1
2	Temperature Cycle	H : +100°C 15min ∫ 5 min L : -40°C 15min	300 Cycles	22 PCS.	0/1
3	Thermal Shock	H : +100°C 5min ∫ 10 sec L : -10°C 5min	300 Cycles	22 PCS.	0/1
4	High Temperature Storage	Temp. : 100°C	1000 Hrs.	22 PCS.	0/1
5	Low Temperature Storage	Temp. : -40°C	1000 Hrs.	22 PCS.	0/1
6	DC Operating Life	I _F = 20 mA / 25°C	1000 Hrs.	22 PCS.	0/1
7	High Temperature / High Humidity	85°C/85%RH	1000 Hrs.	22 PCS.	0/1

Precautions For Use**1. Over-current-proof**

Customer must apply resistors for protection, otherwise slight voltage shift will cause big current change (Burn out will happen).

2. Storage

- 2.1 Do not open moisture proof bag before the products are ready to use.
- 2.2 Before opening the package: The LEDs should be kept at 30°C or less and 90%RH or less.
- 2.3 After opening the package: The LED's floor life is 1 year under 30°C or less and 60% RH or less.

If unused LEDs remain, it should be stored in moisture proof packages.

- 2.4 If the moisture absorbent material (silica gel) has faded away or the LEDs have exceeded the storage time, baking treatment should be performed using the following conditions.

Baking treatment : 60±5°C for 24 hours.

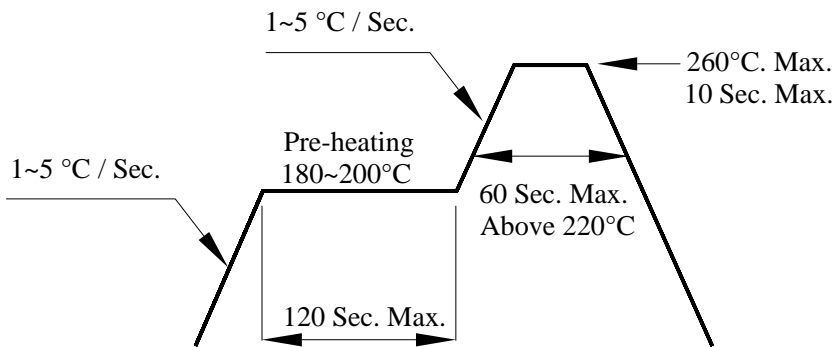
3. Soldering Condition**3.1 Pb-free solder temperature profile**

- 3.2 Reflow soldering should not be done more than two times.
- 3.3 When soldering, do not put stress on the LEDs during heating.
- 3.4 After soldering, do not warp the circuit board.

4.Soldering Iron

Each terminal is to go to the tip of soldering iron temperature less than 350°C for 3 seconds within once in less than the soldering iron capacity 25W. Leave two seconds and more intervals, and do soldering of each terminal. Be careful because the damage of the product is often started at the time of the hand solder.

5.Repairing

Repair should not be done after the LEDs have been soldered. When repairing is unavoidable, a double-head soldering iron should be used (as below figure). It should be confirmed beforehand whether the characteristics of the LEDs will or will not be damaged by repairing.

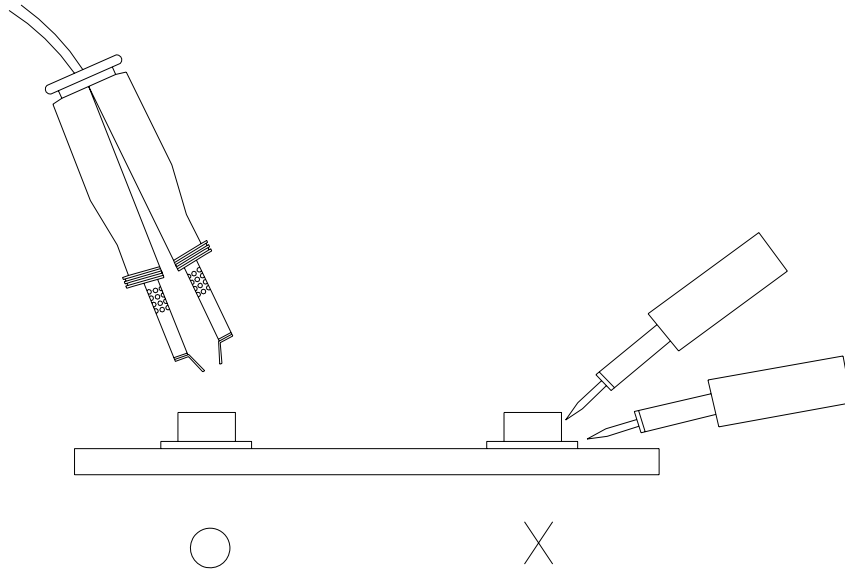

6. Handling Indications

During processing, mechanical stress on the surface should be minimized as much as possible. Sharp objects of all types should not be used to pierce the sealing compound

EVERLIGHT ELECTRONICS CO., LTD.
Office: No 25, Lane 76, Sec 3, Chung Yang Rd,
Tucheng, Taipei 236, Taiwan, R.O.C

Tel: 886-2-2267-2000, 2267-9936
Fax: 886-2267-6244, 2267-6189, 2267-6306
<http://www.everlight.com>