

SMD ■ Power Top View LEDs 67-31EZ-BJP-N7AABBA6F-2T8-AM



Features

- P-LCC-3 package.
- Colored diffused resin.
- Wide viewing angle 120°.
- Inner reflector and white package.
- Brightness: 1120 to 2800mcd at 30mA
- Precondition: Bases on JEDEC J-STD 020D Level 2
- Qualification according to AEC-Q101 rev C.
- Automotive reflow profile (IR reflow or wave soldering)

Applications

- Automotive backlighting or indicator: Dashboard, switch, audio and video equipments...etc.
- Backlight: LCD, switches, symbol, mobile phone and illuminated advertising.
- Display for indoor and outdoor application.
- Ideal for coupling into light guides.
- Substitution of traditional light.
- Optical indicator.

Device Selection Guide

Chip Materials	Emitted Color	Resin Color
InGaN	Ice Blue	Slightly Green Dotted

Absolute Maximum Ratings (Ta=25°C)

Parameter	Symbol	Rating	Unit
Reverse Voltage	V_R	5	V
Forward Current	I_F	30	mA
Peak Forward Current (Duty 1/10 @1KHz)	I_{FP}	100	mA
Power Dissipation	P_d	110	mW
Junction Temperature	T_j	125	°C
Operating Temperature	T_{opr}	-40 ~ +100	°C
Storage Temperature	T_{stg}	-40 ~ +110	°C
Thermal Resistance	$R_{th\ J-A}$	600	K/W
	$R_{th\ J-S}$	400	K/W
ESD (Classification acc. AEC Q101)	ESD_{HBM}	2000	V
	ESD_{MM}	200	V
Soldering Temperature	T_{sol}	Reflow Soldering : 260 °C for 30 sec. Hand Soldering : 350 °C for 3 sec.	

Electro-Optical Characteristics (Ta=25°C)

Parameter	Symbol	Min.	Typ.	Max.	Unit	Condition
Luminous Intensity	I _v	1120	-----	2800	mcd	I _F =30mA
Viewing Angle	2θ _{1/2}	-----	120	-----	deg	I _F =30mA
Forward Voltage	V _F	2.6	----	3.8	V	I _F =30mA

Note:

1. Tolerance of Luminous Intensity: ±11%
2. Tolerance of Forward Voltage: ±0.1V

Bin Range of Luminous Intensity

Bin Code	Min.	Max.	Unit	Condition
AA	1120	1400	mcd	I _F =30mA
AB	1400	1800		
BA	1800	2240		
BB	2240	2800		

Note:

Tolerance of Luminous Intensity: ±11%

Bin Range of Chromaticity Coordinates Specifications

Bin Code	CIE x	CIE y	Condition
5J	0.1941	0.2753	$I_F = 30\text{mA}$
	0.2000	0.2746	
	0.1960	0.2588	
	0.1902	0.2595	
5K	0.1853	0.2762	
	0.1941	0.2753	
	0.1902	0.2595	
	0.1814	0.2605	
6J	0.1980	0.2910	
	0.2039	0.2904	
	0.2000	0.2746	
	0.1941	0.2753	
6K	0.1893	0.2920	
	0.1980	0.2910	
	0.1941	0.2753	
	0.1853	0.2762	

Note:
 Tolerance of Chromaticity Coordinates: ± 0.01

The C.I.E. 1931 Chromaticity Diagram

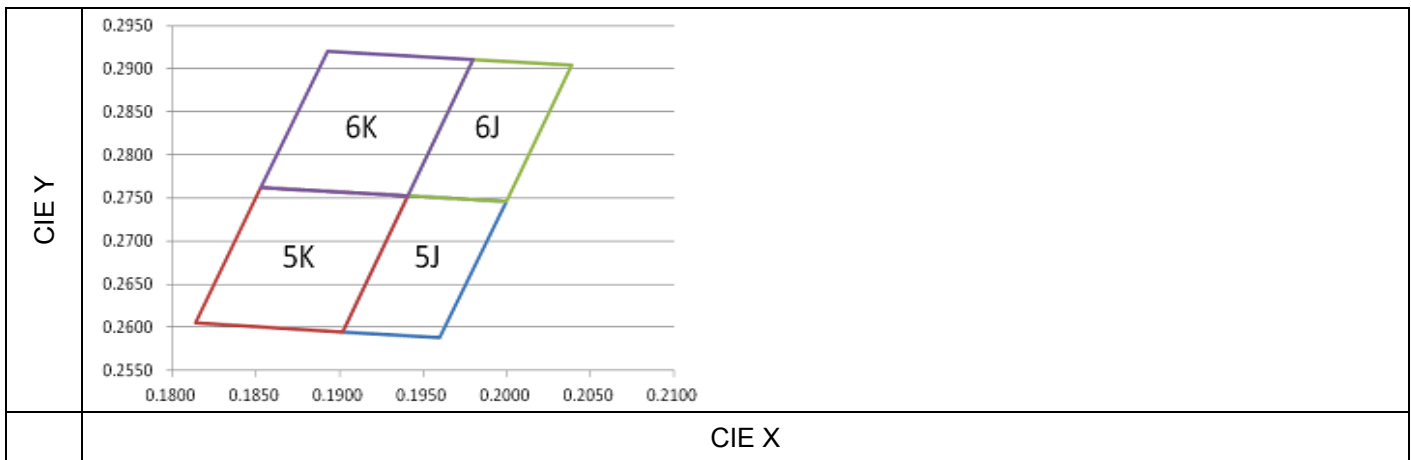

Note:
 Tolerance of Chromaticity Coordinates: ± 0.01

Typical Electro-Optical Characteristics Curves

Typical Curve of Spectral Distribution

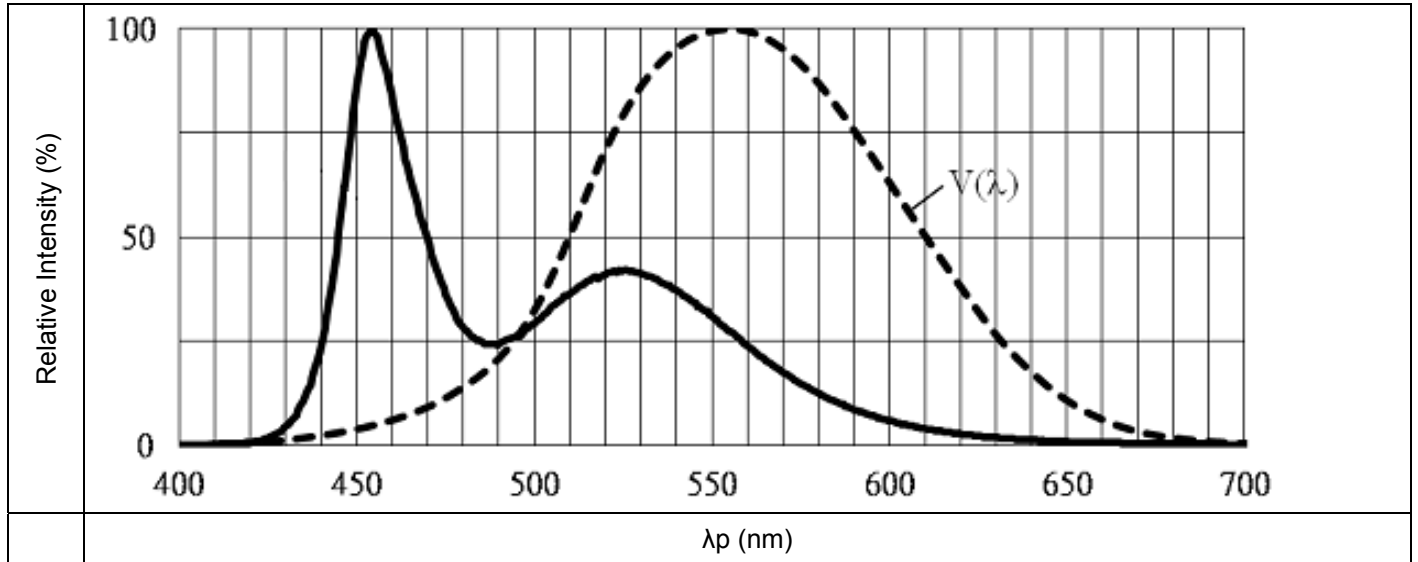

Note: $V(\lambda)$ =Standard eye response curve; $I_f = 30\text{mA}$

Diagram Characteristics of Radiation

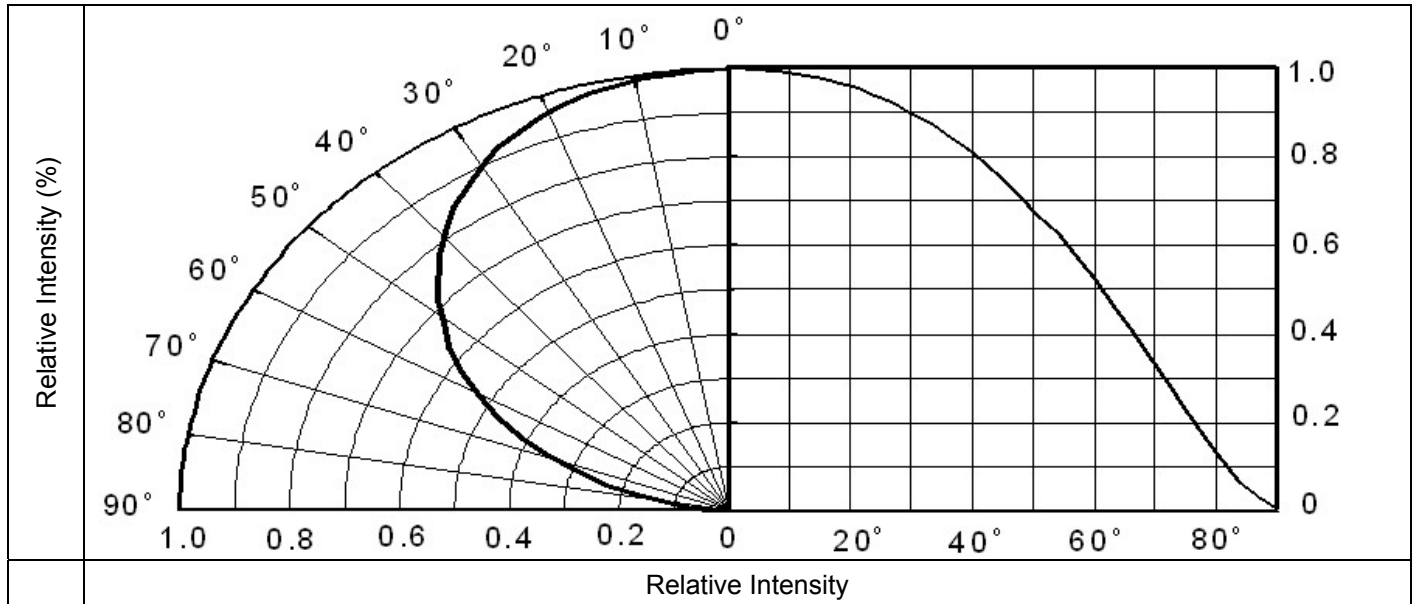

Forward Current vs. Forward Voltage (Ta=25°C)

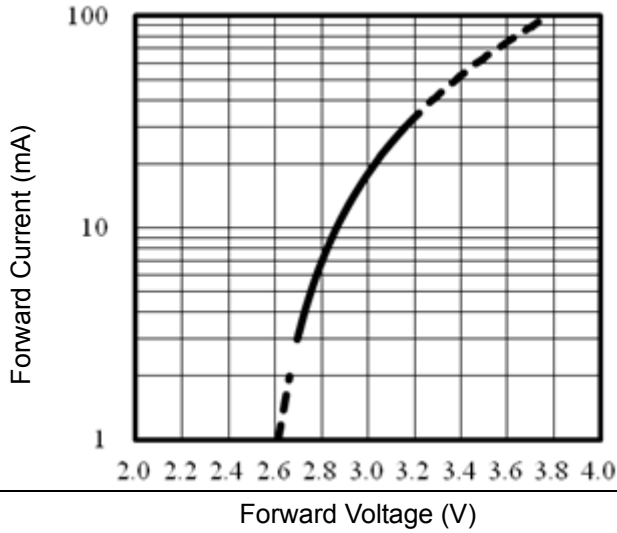

Chromaticity Coordinates vs. Forward Current (Ta=25°C)

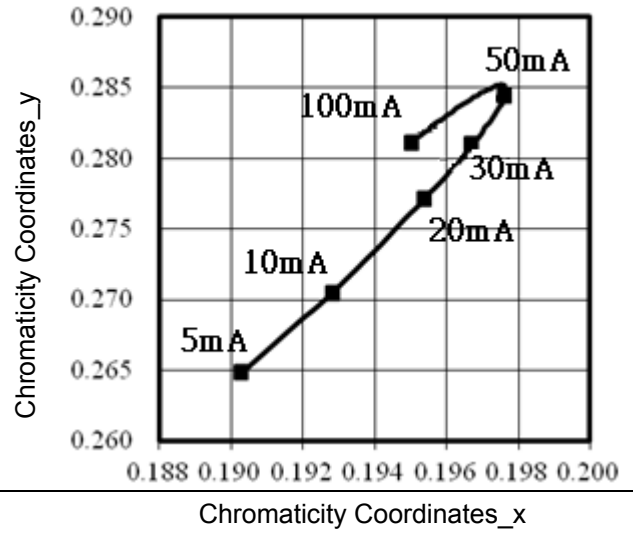

Relative Luminous Intensity vs. Forward Current (Ta=25°C)

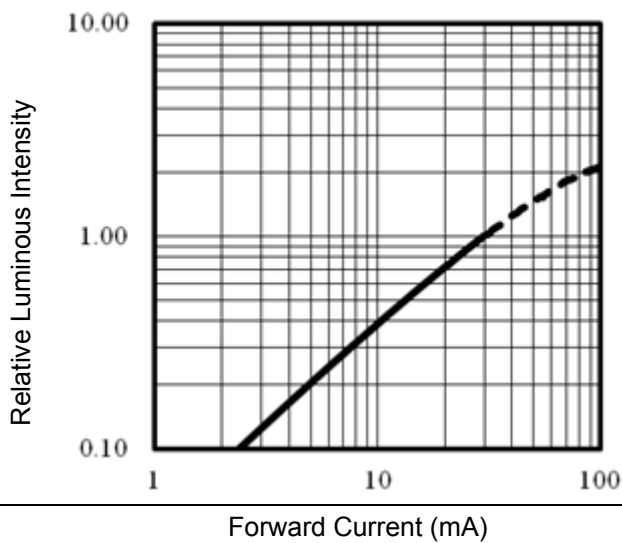

Max. Permissible Forwarded Current (Ta=25°C)

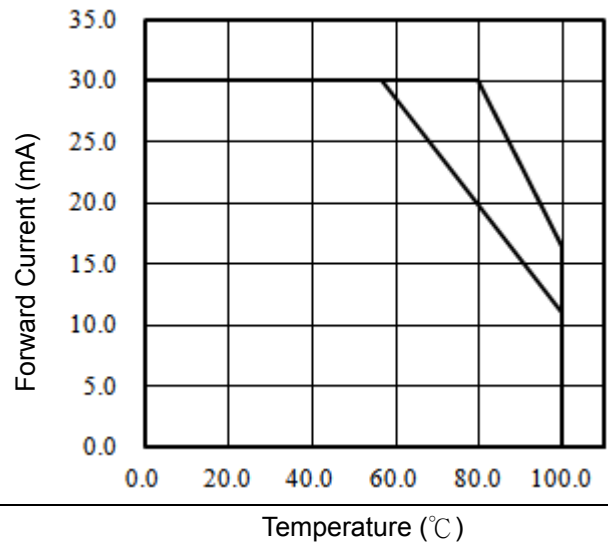

Package Dimension

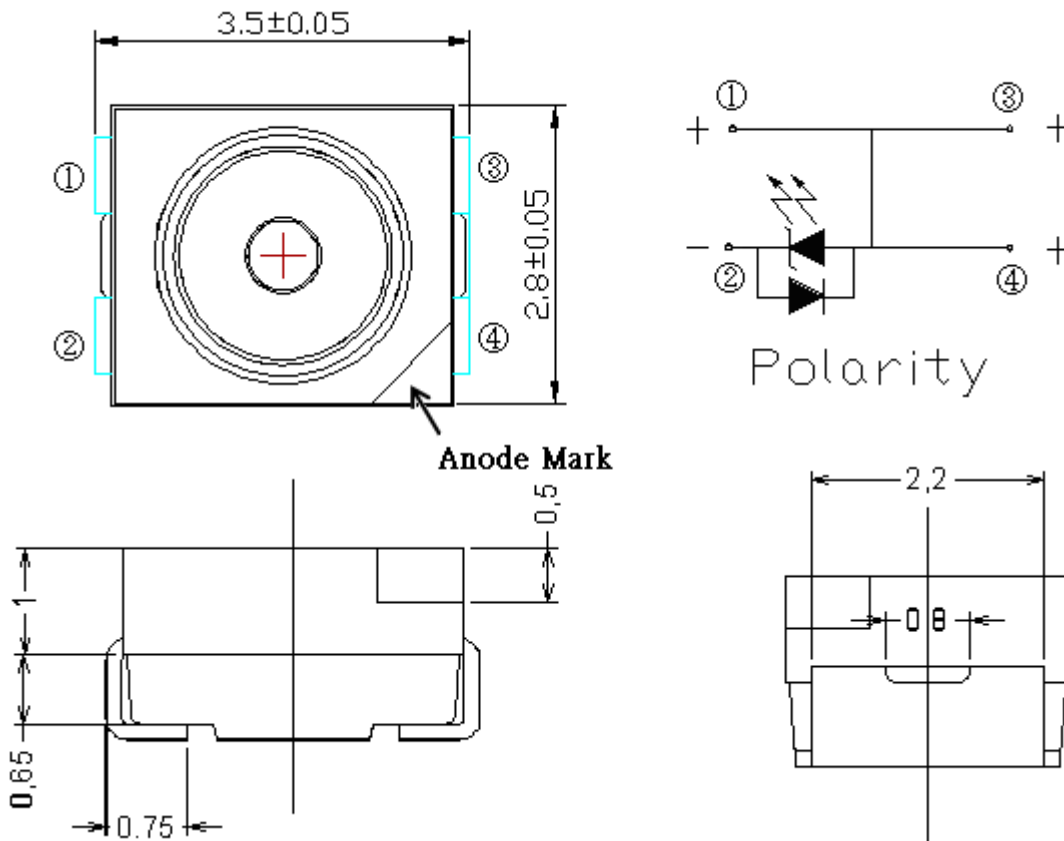

Note: Tolerances unless mentioned ± 0.1 mm. Unit = mm

Moisture Resistant Packing Materials

Label Explanation



- CPN: Customer's Product Number
- P/N: Product Number
- QTY: Packing Quantity
- CAT: Luminous Intensity Rank
- HUE: Dom. Wavelength Rank
- REF: Forward Voltage Rank
- LOT No: Lot Number

Reel Dimensions

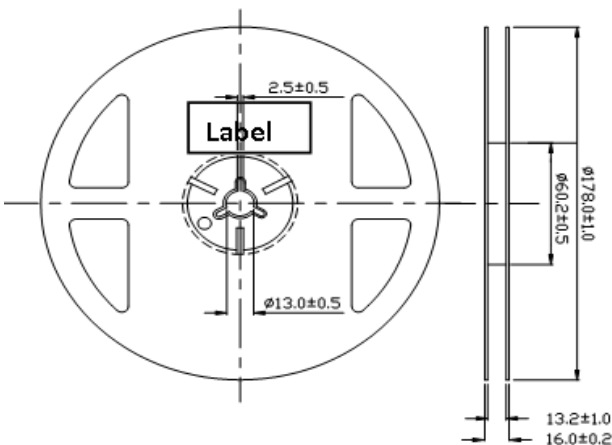

Carrier Tape Dimensions: Loaded Quantity 2000 pcs Per Reel

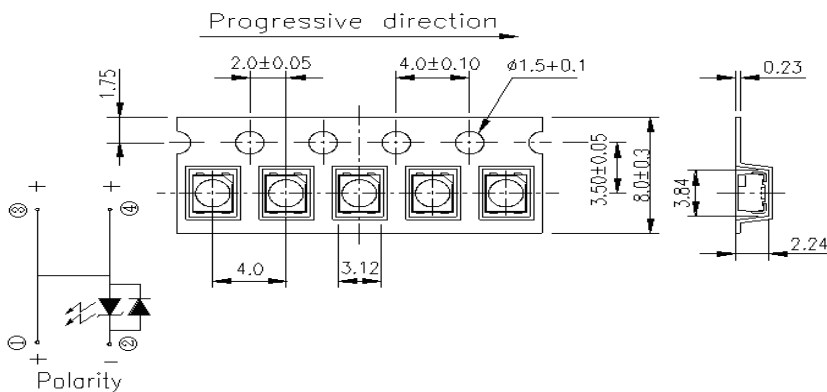

Note: Tolerances unless mentioned ± 0.1 mm. Unit = mm

Moisture Resistant Packing Process

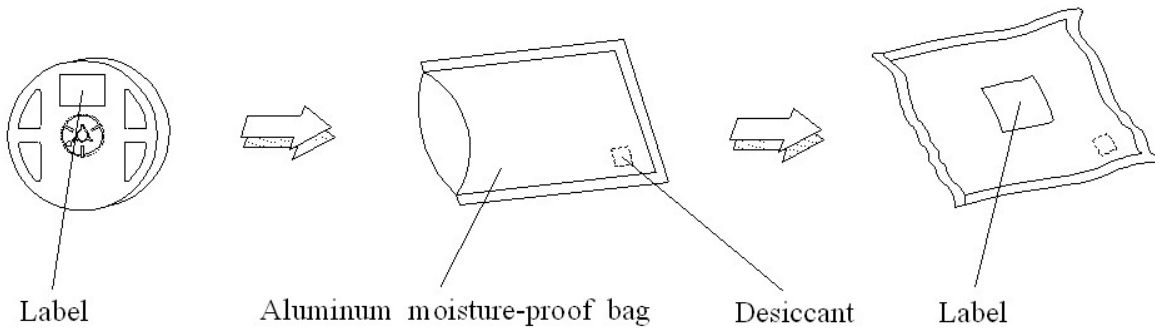

Note: Tolerances unless mentioned $\pm 0.1\text{mm}$. Unit = mm

Precautions for Use

1. Soldering Condition (Reference: IPC/JEDEC J-STD-020D)

1.1 (A) Maximum Body Case Temperature Profile for evaluation of Reflow Profile

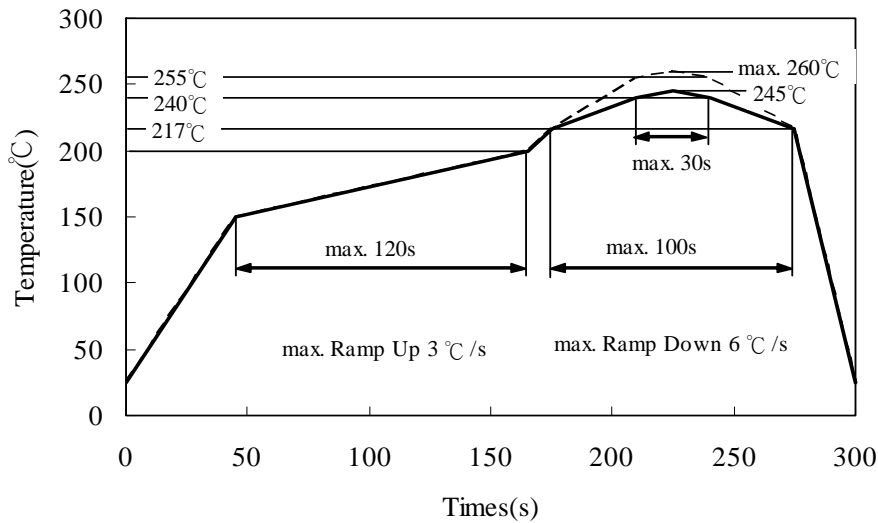

(B) Recommend soldering pad

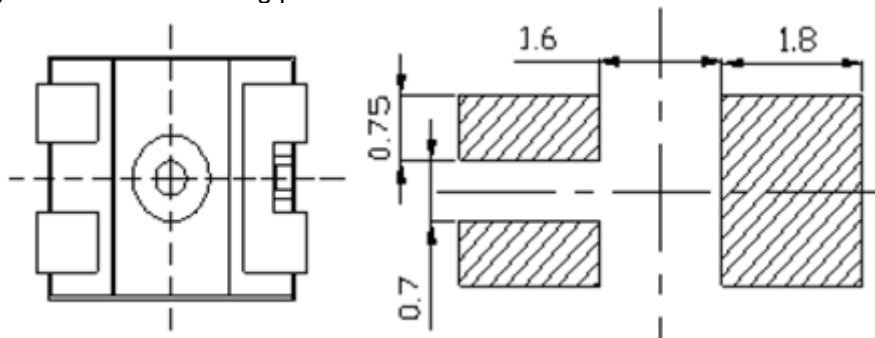

Note: Tolerances unless mentioned $\pm 0.1\text{mm}$. Unit = mm

2. Current limiting

A resistor should be used to limit current spikes that can be caused by voltage fluctuations. Otherwise damage could occur.

3. Storage

3.1 Moisture proof bag should only be opened immediately prior to usage.

3.2 Environment should be less than 30°C and 60% RH when moisture proof bag is opened.

3.3 After opening the package MSL Conditions stated on page 1 of this spec should not be exceeded.

3.4 If the moisture sensitivity card indicates higher than acceptable moisture, the component should be baked at min. 60deg +/-5deg for 24 hours.

4. Iron Soldering

Hand soldering is not recommended for regular production. These guidelines are for rework only. Soldering iron tip should contact each terminal no more than 3 sec at 350°C, using soldering iron with nominal power less than 25W. Allow min. 2 sec. between soldering intervals.

5. Usage

Do not exceed the values given in this specification.

Application Restrictions

High reliability applications such as military/aerospace, automotive safety/security systems, and medical equipment may require different product. If you have any concerns, please contact Everlight before using this product in your application. This specification guarantees the quality and performance of the product as an individual component. Do not use this product beyond the specification described in this document.

Revision History

Rev.	Modified date	File modified contents
1	2012/09/07	New Spec
2	2012/11/06	Preliminary
3	2013/06/14	Change the new template