

Technical Data Sheet - Preliminary Power Top View LEDs

67-31E/YSSC-AV2X1B23Z5/2T

Features

- PLCC-3 package.
- High flux output.
- High current capability.
- White package.
- Optical indicator.
- Colorless clear window.
- Ideal for backlight and light pipe application.
- Inter reflector.
- Wide viewing angle.
- Suitable for automatic placement equipment.
- Suitable for reflow and wave solder processes.
- Available on tape and reel (8mm Tape).
- Pb-free.
- The product itself will remain within RoHS compliant version.



Descriptions

- The 67-31E series is available in soft orange, red and yellow. Due to the package design, the LED has wide viewing angle and optimized light coupling by inter reflector.
- This feature makes the ideal for light pipe application. The low current requirement makes this device ideal for portable equipment or any other application where power is at a premium.

Applications

- Indicator and backlight for audio and video equipment.
- Indicator and backlight in office and family equipment.
- Flat backlight for LCD's, switches and symbols.
- Light pipe application.
- General use.

Device Selection Guide

Chip	Emitted Color	Resin Color
Material		
AlGaInP	Brilliant Yellow	Water Clear

Technical Data Sheet - Preliminary
Power Top View LEDs

67-31E/YSSC-AV2X1B23Z5/2T

Package Dimensions

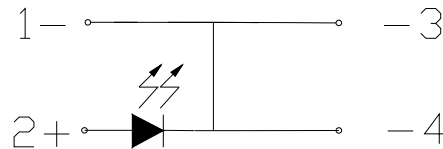
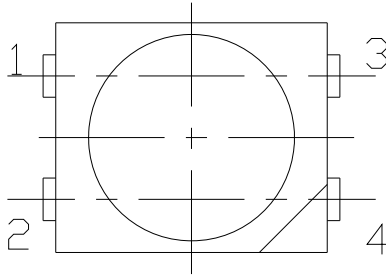

Polarity

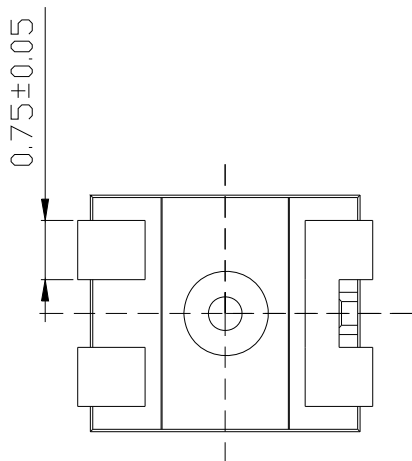
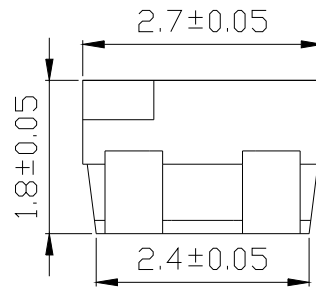
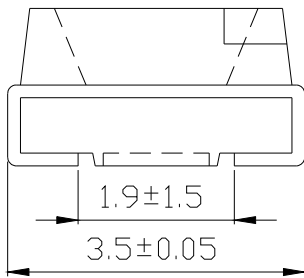

Recommended soldering pad design

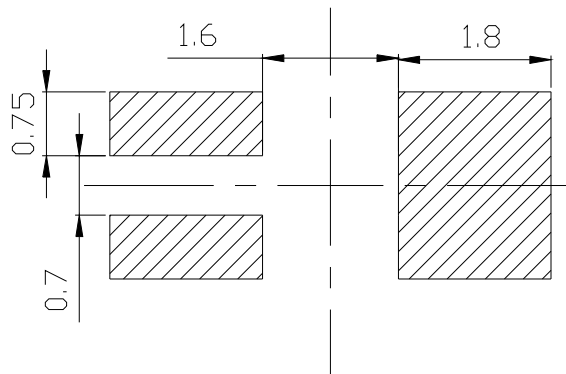

Note: The tolerances unless mentioned is $\pm 0.1\text{mm}$; Unit = mm

Technical Data Sheet - Preliminary
Power Top View LEDs

67-31E/YSSC-AV2X1B23Z5/2T

Absolute Maximum Ratings (TA=25°C)

Parameter	Symbol	Rating	Unit
Reverse Voltage	V _R	5	V
Forward Current	I _F	50	mA
Peak Forward Current(Duty 1/10 @1KHz)	I _{FP}	100	mA
Power Dissipation	P _d	120	mW
Electrostatic Discharge(HBM)	ESD	2000	V
Operating Temperature	T _{opr}	-40 ~ +85	°C
Storage Temperature	T _{stg}	-40 ~ +90	°C
Soldering Temperature	T _{sol}	Reflow Soldering : 260 °C for 10 sec. Hand Soldering : 350 °C for 3 sec.	

Electronic Optical Characteristics :

Parameter	Symbol	Min.	Typ.	Max.	Unit	Condition
Luminous Intensity	I _V	900	-----	2250	mcd	I _F =50mA
Viewing Angle	2θ _{1/2}	-----	120	-----	deg	I _F =50mA
Peak Wavelength	λ _p	-----	591	-----	nm	I _F =50mA
Dominant Wavelength	λ _d	585.5	-----	594.5	nm	I _F =50mA
Spectrum Radiation Bandwidth	△λ	-----	15	-----	nm	I _F =50mA
Forward Voltage	V _F	1.75	-----	2.55	V	I _F =50mA
Reverse Current	I _R	-----	-----	10	μA	V _R =5V

Notes:

1. Tolerance of Luminous Intensity ±11%
2. Tolerance of Dominant Wavelength ±1nm
3. Tolerance of Forward Voltage ±0.1V

**Technical Data Sheet - Preliminary
Power Top View LEDs**
67-31E/YSSC-AV2X1B23Z5/2T
Bin Range of Luminous Intensity

Bin	Min	Max	Unit	Condition
V2	900	1120	mcd	I _F =50mA
W1	1120	1420		
W2	1420	1800		
X1	1800	2250		

Bin Range of Dominant Wavelengths

Group	Bin Code	Min.	Max.	Unit	Condition
A	D3	585.5	588.5	nm	I _F =50mA
	D4	588.5	591.5		
	D5	591.5	594.5		

Bin Range of Forward Voltage

Group	Bin	Min	Max	Unit	Condition
B23	0	1.75	1.95	V	I _F =50mA
	1	1.95	2.15		
	2	2.15	2.35		
	3	2.35	2.55		

Notes:

1. Tolerance of Luminous Intensity $\pm 11\%$
2. Tolerance of Dominant Wavelength $\pm 1\text{nm}$
3. Tolerance of Forward Voltage $\pm 0.1\text{V}$

Technical Data Sheet - Preliminary
Power Top View LEDs

67-31E/YSSC-AV2X1B23Z5/2T

Typical Electro-Optical Characteristic Curves

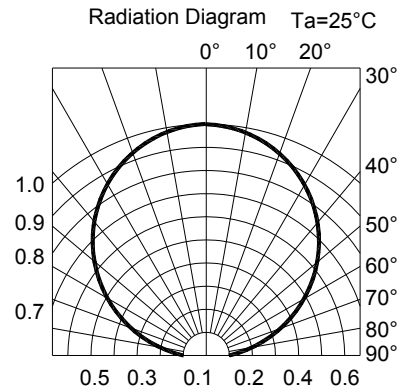
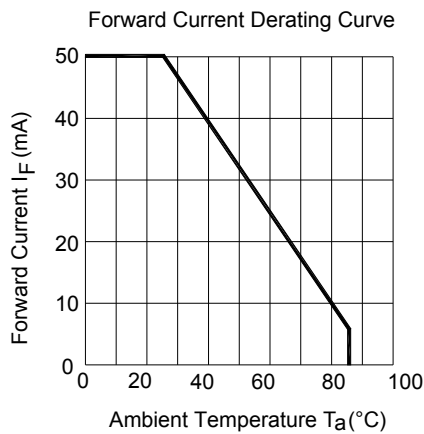
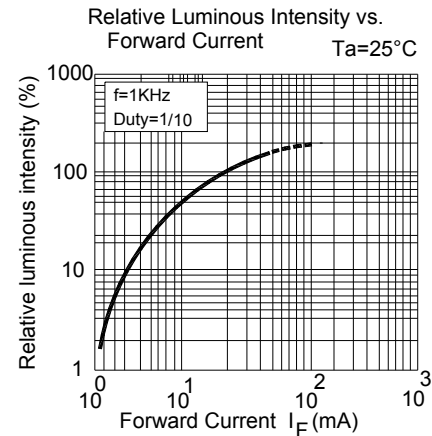
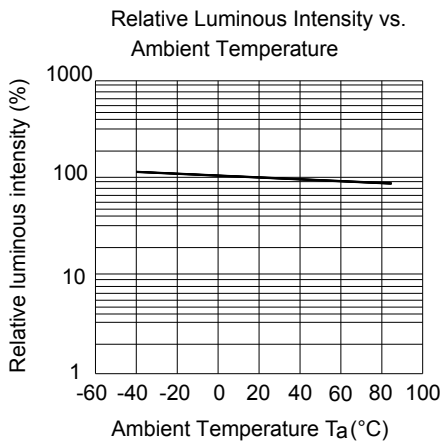
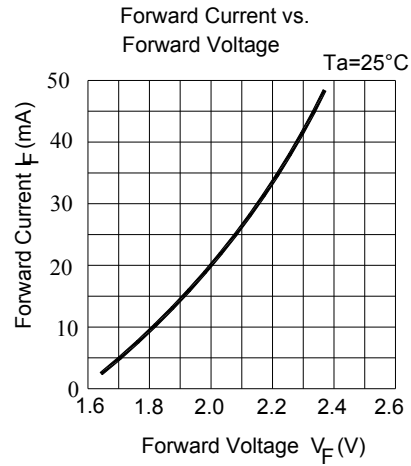
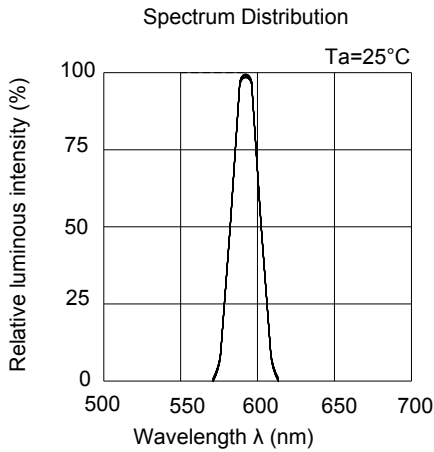

Technical Data Sheet - Preliminary
Power Top View LEDs

67-31E/YSSC-AV2X1B23Z5/2T

Label Explanation

CAT: Luminous Intensity Rank

HUE: Dom. Wavelength Rank

REF: Forward Voltage Rank



Reel Dimensions

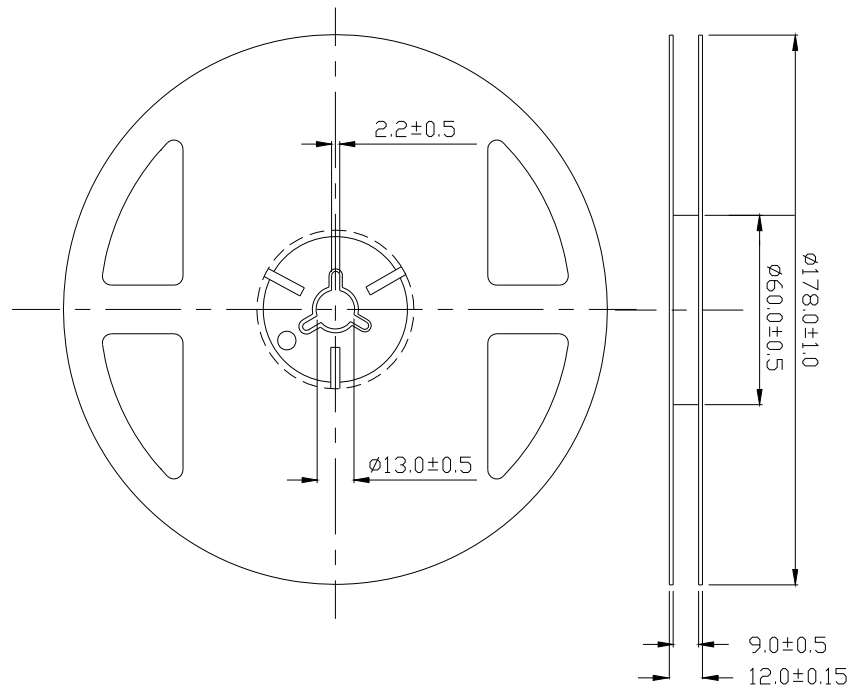

Note: The tolerances unless mentioned is ± 0.1 mm; Unit = mm

Technical Data Sheet - Preliminary
Power Top View LEDs

67-31E/YSSC-AV2X1B23Z5/2T

Carrier Tape Dimensions; Loaded Quantity 2000 pcs Per Reel

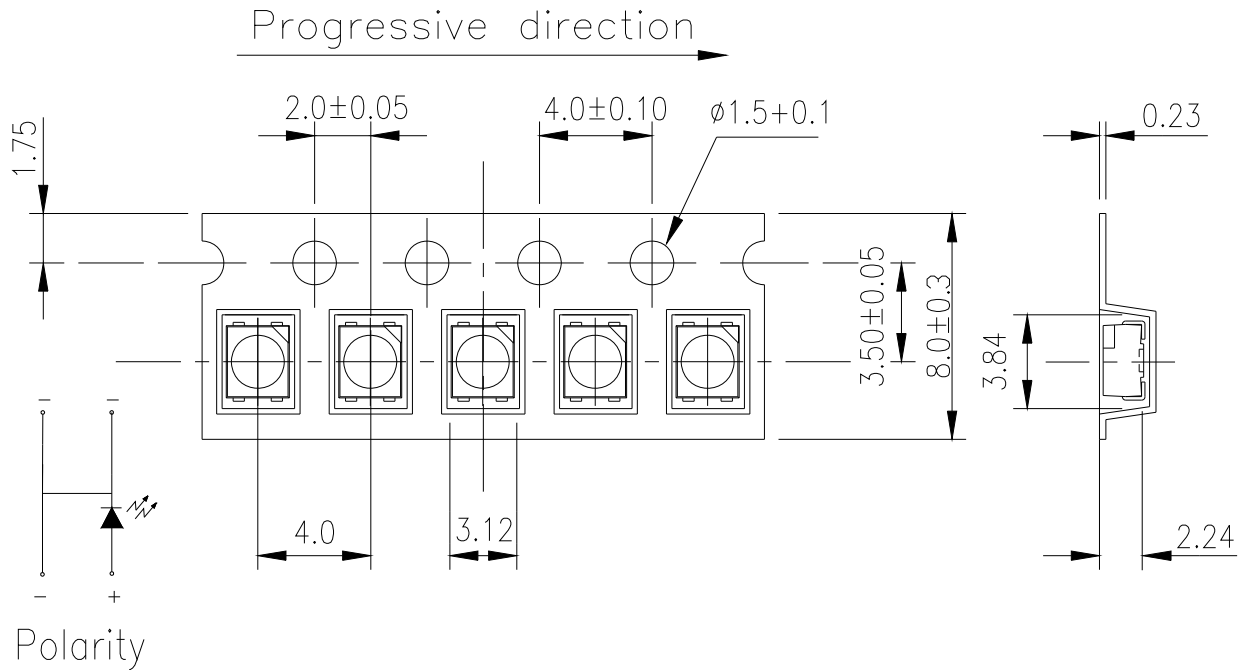

Note: The tolerances unless mentioned is ±0.1mm; Unit = mm

Moisture Resistant Packaging

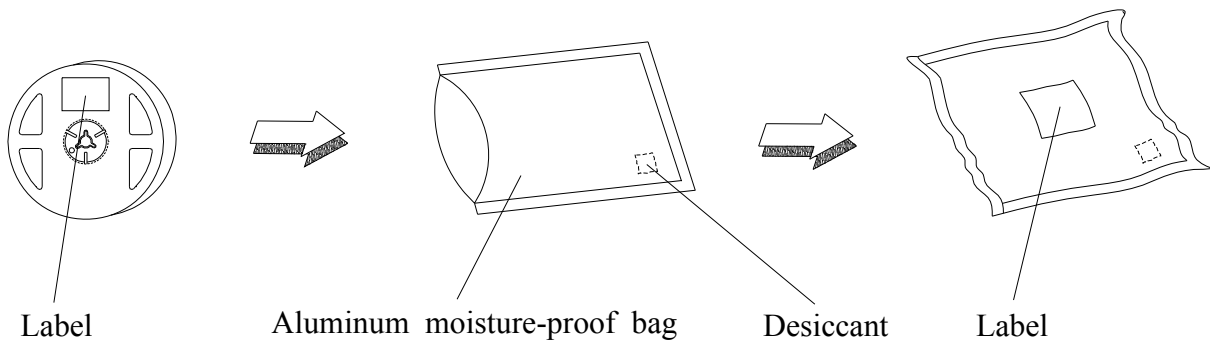

Technical Data Sheet - Preliminary

Power Top View LEDs

67-31E/YSSC-AV2X1B23Z5/2T

Reliability Test Items and Conditions

The reliability of products shall be satisfied with items listed below.

Confidence level : 90%

LTPD : 10%

No.	Items	Test Condition	Test Hours/Cycles	Sample Size	Ac/Re
1	Reflow Soldering	Temp. : 260°C±5°C Max. 10 sec.	6 Min.	22 PCS	0/1
2	Temperature Cycle	H : +100°C 15min ↓ 5 min L : -40°C 15min	300 Cycles	22 PCS.	0/1
3	Thermal Shock	H : +100°C 5min ↓ 10 sec L : -10°C 5min	300 Cycles	22 PCS.	0/1
4	High Temperature Storage	Temp. : 100°C	1000 Hrs.	22 PCS.	0/1
5	Low Temperature Storage	Temp. : -40°C	1000 Hrs.	22 PCS.	0/1
6	DC Operating Life	I _F = 50 mA / 25°C	1000 Hrs.	22 PCS.	0/1
7	High Temperature / High Humidity	85°C/85%RH	1000 Hrs.	22 PCS.	0/1

Technical Data Sheet - Preliminary Power Top View LEDs

67-31E/YSSC-AV2X1B23Z5/2T

Precautions for Use

1. Over-current-proof

Customer must apply resistors for protection, otherwise slight voltage shift will cause big current change (Burn out will happen).

2. Storage

2.1 Do not open moisture proof bag before the products are ready to use.

2.2 Before opening the package: The LEDs should be kept at 30°C or less and 90%RH or less.

2.3 After opening the package: The LED's floor life are 168 hours under 30°C or less and 60% RH or less. If unused LEDs remain, it should be stored in moisture proof packages.

2.4 If the moisture absorbent material (silica gel) has faded away or the LEDs have exceeded the storage time, baking treatment should be performed using the following conditions.

Baking treatment : 60±5°C for 24 hours.

3. Soldering Condition

3.1 Pb-free solder temperature profile

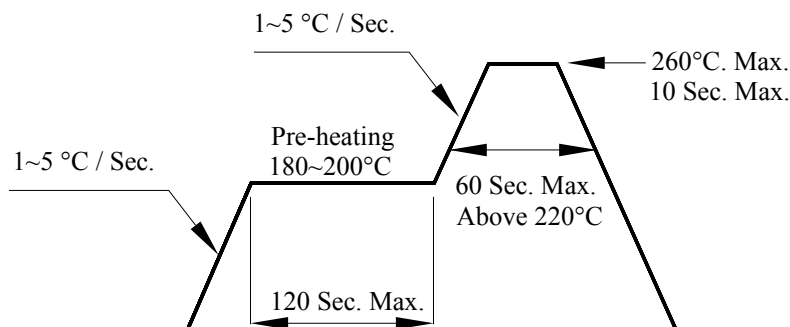

3.2 Reflow soldering should not be done more than two times.

3.3 When soldering, do not put stress on the LEDs during heating.

3.4 After soldering, do not warp the circuit board.

4. Soldering Iron

Each terminal is to go to the tip of soldering iron temperature less than 350°C for 3 seconds within once in less than the soldering iron capacity 25W. Leave two seconds and more intervals, and do soldering of each terminal. Be careful because the damage of the product is often started at the time of the hand solder.

5. Repairing

Technical Data Sheet - Preliminary
Power Top View LEDs

67-31E/YSSC-AV2X1B23Z5/2T

Repair should not be done after the LEDs have been soldered. When repairing is unavoidable, a double-head soldering iron should be used (as below figure). It should be confirmed beforehand whether the characteristics of the LEDs will or will not be damaged by repairing.

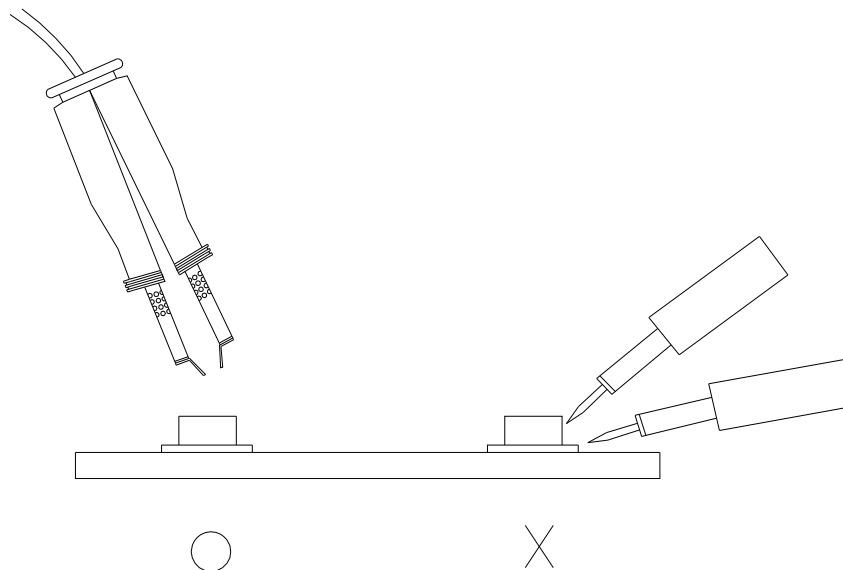

EVERLIGHT ELECTRONICS CO., LTD.
Office: No 25, Lane 76, Sec 3, Chung Yang Rd,
Tucheng, Taipei 236, Taiwan, R.O.C

Tel: 886-2-2267-2000, 2267-9936
Fax: 886-2267-6244, 2267-6189, 2267-6306
<http://www.everlight.com>