



MODEL NO: 67-22SRUGC/TR8

Device Number : DSE-672-005 REV. 1.2

**TOP LED**

ECN : \_\_\_\_\_ Page: 1/9

**Features :**

- P-LCC-2package.
- White package.
- Optical indicator.
- Colorless clear window.
- Ideal for backlight and light pipe application.
- Inter reflector.
- Low (2mA) current operation.
- Wide viewing angle.
- Computable with automatic placement equipment.
- Suitable for vapor-phase reflow, Infrared reflow and wave solder processes.
- Available on tape and reel (8mm Tape).

**Descriptions :**

- The 67-22 series is available in soft orange, green, blue and yellow.
- Due to the package design, the LED has wide viewing angle and optimized light coupling by inter reflector, this feature makes the SMT TOP LED ideal for light pipe application.
- The low current requirement makes this device ideal for portable equipment or any other application where power is at a premium.

**Applications :**

- Automotive: backlight in dashboards and switches.
- Telecommunication: indicator and backlight in telephone and fax.
- Indicator and backlight for audio and video equipment.
- Indicator and backlight in office and family equipment.
- Flat backlight for LCD's, switches and symbols.
- Light pipe application.
- General use.

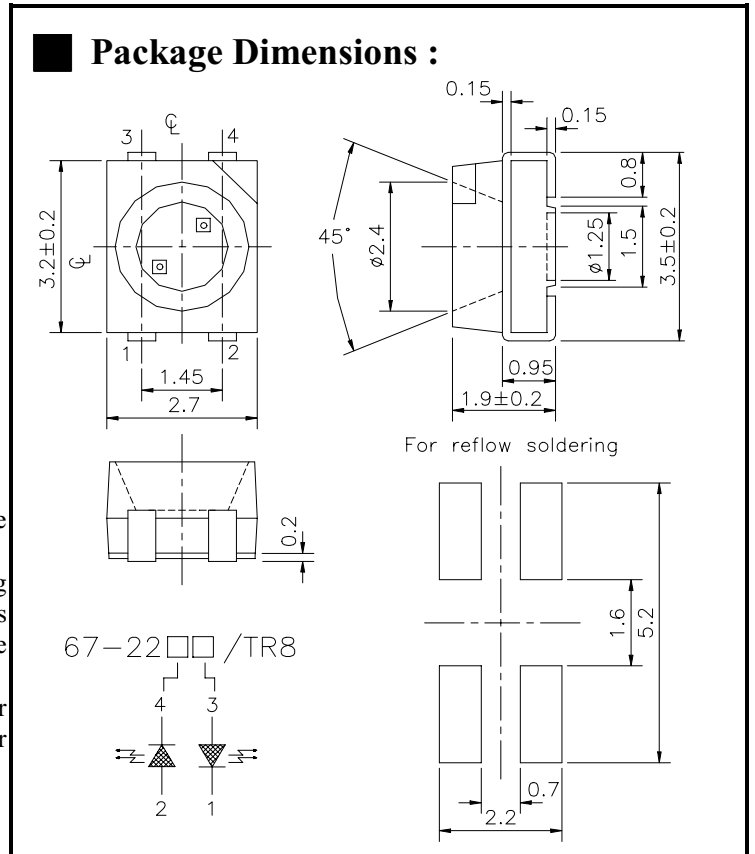

**Notes:**

Tolerances Unless Dimension  $\pm 0.1\text{mm}$   
 Angle  $\pm 0.5^\circ$   
 Unit = mm

Part NO.	Chip		Lens Color
	Material	Emitted Color	
67-22SRUGC/TR8	GaAlAs	Super Red	Water Clear
	GaP	Super Green	

Office: NO. 25, Lane 76, Sec.3, Chung Yang Rd., Tucheng 236, Taipei, Taiwan, R.O.C.

TEL: 886-2-2267-2000, 2267-9936

FAX: 886-2-2267-6244, 2267-6189, 2267-6306

http://www.everlight.com



MODEL NO: 67-22SRUGC/TR8

Device Number : DSE-672-005 REV. 1.2

**TOP LED**

ECN : \_\_\_\_\_ Page: 2/9

**Package Dimensions :**

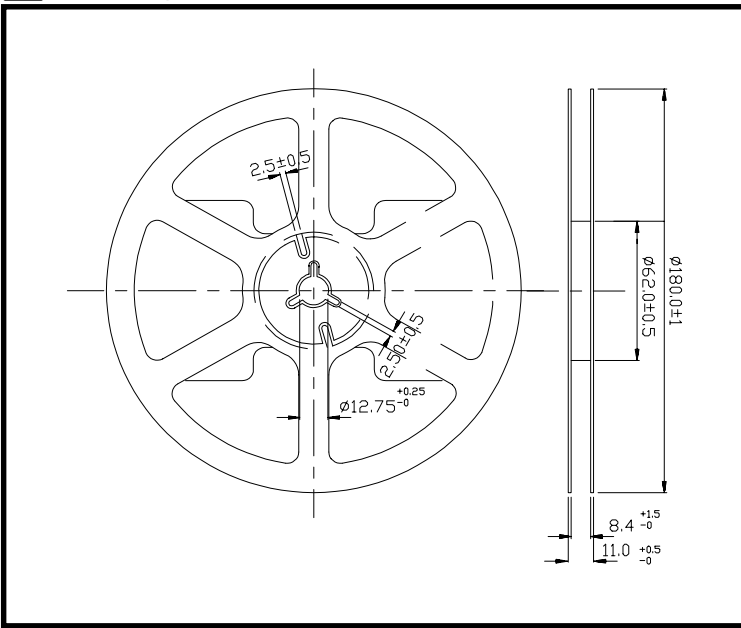

**Loaded quantity per reel 2000 PCS/reel :**

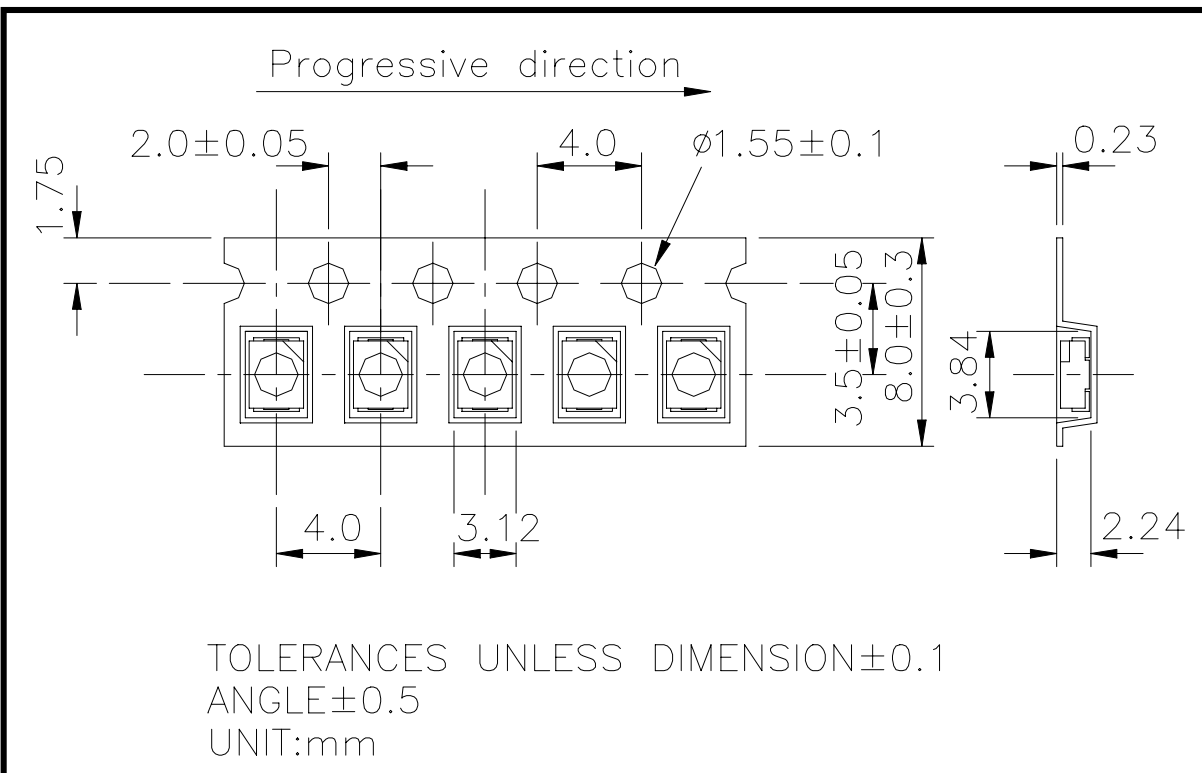



MODEL NO: 67-22SRUGC/TR8

Device Number : DSE-672-005 REV. 1.2

TOP LED

ECN : Page: 3/9

Absolute Maximum Ratings at Ta = 25°C (SR) :

Parameter	Symbol	Rating	Unit
Reverse Voltage	Vr	5	V
Forward Current	If	40	mA
Operating Temperature	Topr	-40 ~ +85	°C
Storage Temperature	Tstg	-40 ~ +90	°C
Soldering Temperature	Tsol	260 (for 5 second)	°C
Power Dissipation	Pd	110	mW
Peak Forward Current(Duty 1/10 @ 1KHZ)	If(Peak)	180	mA

Electronic Optical Characteristics (SR) :

Parameter	Symbol	Min.	Typ.	Max.	Unit	Condition
Luminous intensity	Iv	19.3	32.2	-----	mcd	If=20mA
Viewing Angle	2θ 1/2	-----	120	-----	deg	If=20mA
Peak Wavelength	λ p	-----	660	-----	nm	If=20mA
Dominant Wavelength	λ d	-----	643	-----	nm	If=20mA
Spectrum Radiation Bandwidth	Δ λ	-----	20	-----	nm	If=20mA
Forward Voltage	Vf	-----	1.7	2.4	V	If=20mA
Reverse Current	Ir	-----	-----	10	μ A	Vr=5V



MODEL NO: 67-22SRUGC/TR8

Device Number : DSE-672-005 REV. 1.2

TOP LED

ECN : Page: 4/9

Absolute Maximum Ratings at Ta = 25°C (UG) :

Parameter	Symbol	Rating	Unit
Reverse Voltage	Vr	5	V
Forward Current	If	30	mA
Operating Temperature	Topr	-40 ~ +85	°C
Storage Temperature	Tstg	-40 ~ +90	°C
Soldering Temperature	Tsol	260 (for 5 second)	°C
Power Dissipation	Pd	100	mW
Peak Forward Current(Duty 1/10 @ 1KHZ)	If(Peak)	160	mA

Electronic Optical Characteristics (UG) :

Parameter	Symbol	Min.	Typ.	Max.	Unit	Condition
Luminous intensity	Iv	15	25.1	-----	mcd	If=20mA
Viewing Angle	2θ 1/2	-----	120	-----	deg	If=20mA
Peak Wavelength	λ p	-----	570	-----	nm	If=20mA
Dominant Wavelength	λ d	-----	571	-----	nm	If=20mA
Spectrum Radiation Bandwidth	Δ λ	-----	30	-----	nm	If=20mA
Forward Voltage	Vf	-----	2.1	2.4	V	If=20mA
Reverse Current	Ir	-----	-----	10	μ A	Vr=5V



MODEL NO: 67-22SRUGC/TR8

Device Number : DSE-672-005 REV. 1.2

**TOP LED**

ECN : \_\_\_\_\_ Page: 5/9

**Reliability Test Items And Conditions :**

NO	Item	Test Conditions	Test Hours/Cycle	Sample Size	Ac/Re
1	Solder Heat	TEMP : 260°C ± 5 °C	5 SEC	76 PCS	0/1
2	Temperature Cycle	H : +85°C 30min ∩ 5 min L : -55°C 30min	50 CYCLE	76 PCS	0/1
3	Thermal Shock	H : +100°C 5min ∩ 10 sec L : -10°C 5min	50 CYCLE	76 PCS	0/1
4	High Temperature Storage	TEMP : 100°C	1000 HRS	76 PCS	0/1
5	Low Temperature Storage	TEMP : -55°C	1000 HRS	76 PCS	0/1
6	DC Operating Life	If = 20 mA	1000 HRS	76 PCS	0/1
7	High Temperature / High Humidity	85°C/85% RH	1000 HRS	76 PCS	0/1

Products are evaluated according to the above standard reliability criteria.



MODEL NO: 67-22SRUGC/TR8

Device Number : DSE-672-005 REV. 1.2

**TOP LED**

ECN : \_\_\_\_\_ Page: 6/9

**Typical Electro-Optical Characteristic Curves(SR) :**

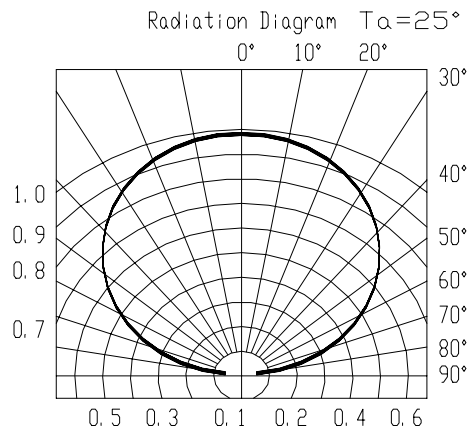
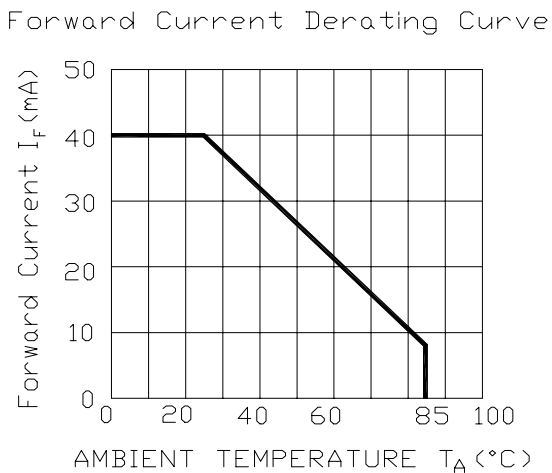
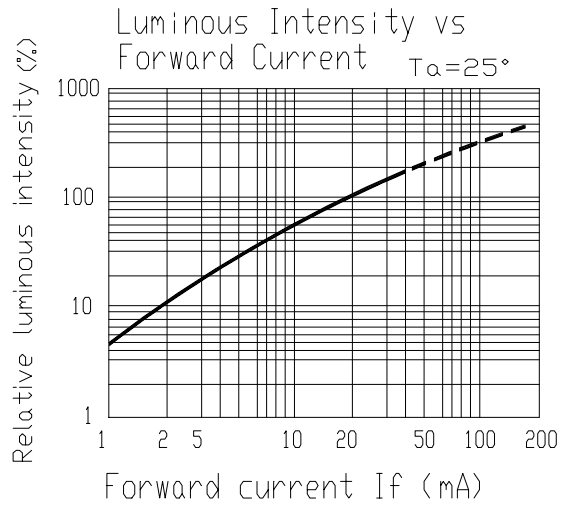
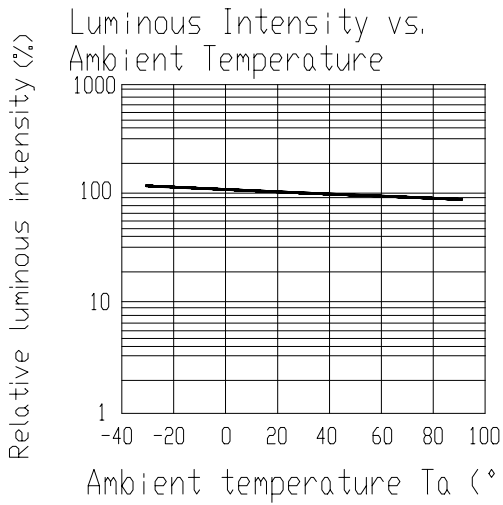
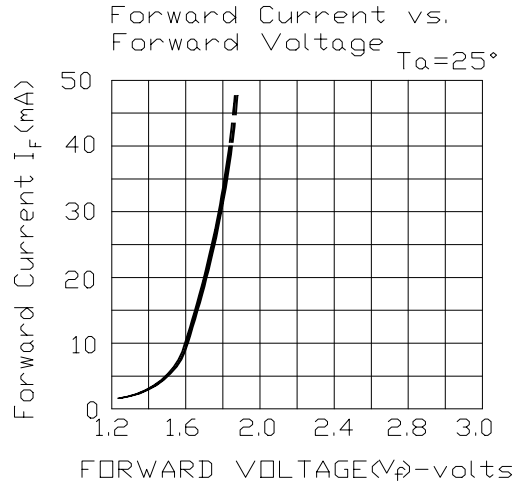
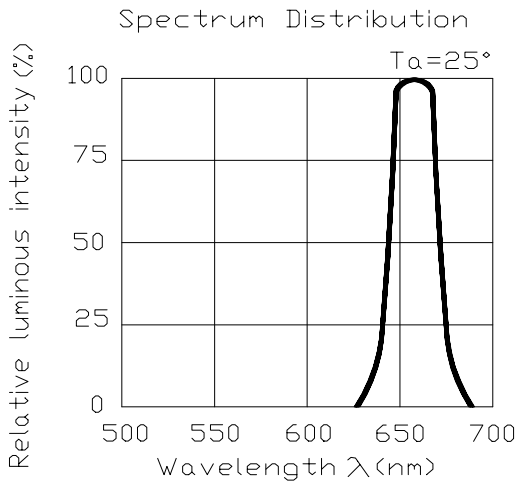



MODEL NO: 67-22SRUGC/TR8

Device Number : DSE-672-005 REV. 1.2

**TOP LED**

ECN : \_\_\_\_\_ Page: 7/9

**Typical Electro-Optical Characteristic Curves(UG) :**

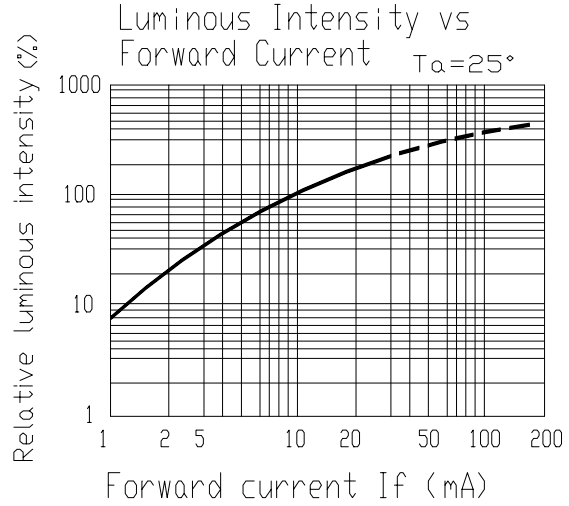
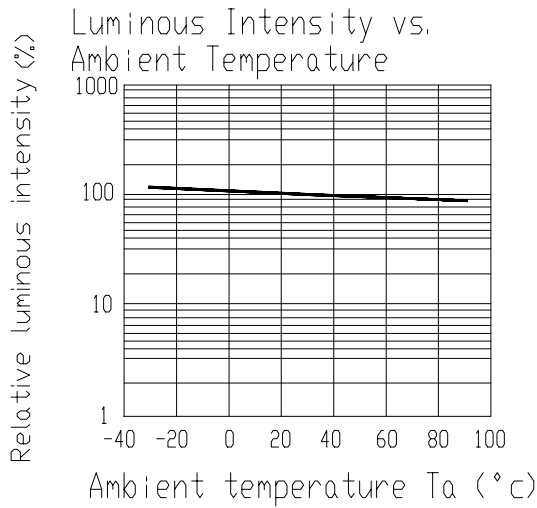
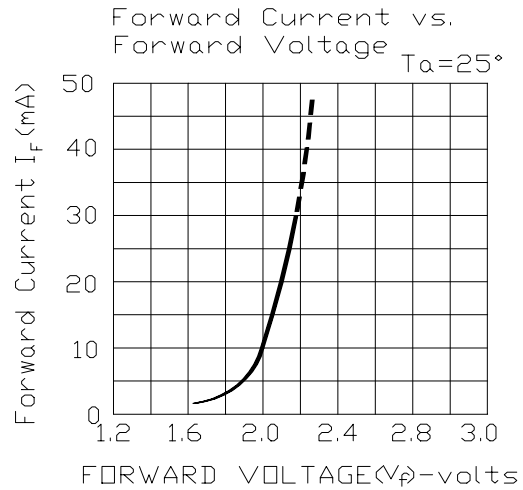
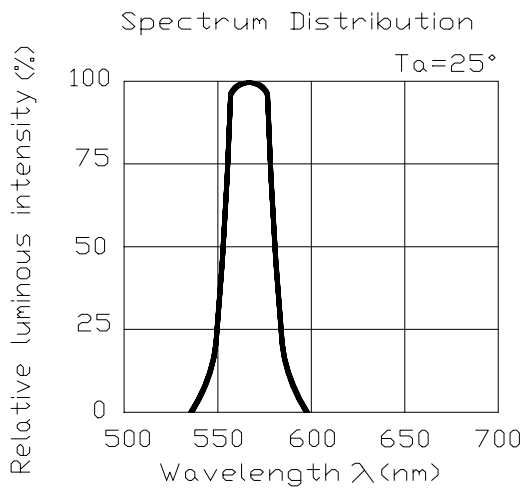

Forward Current Derating Curve

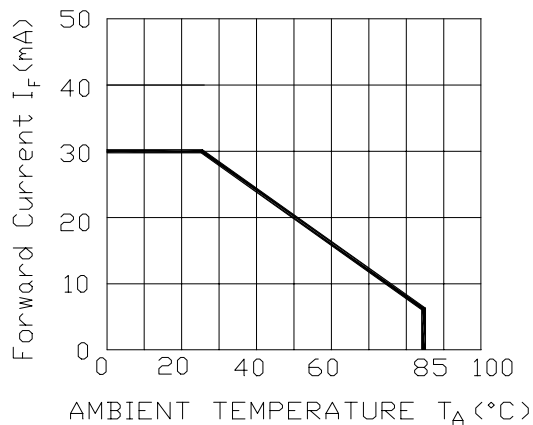

Radiation Diagram  $T_a=25^\circ$

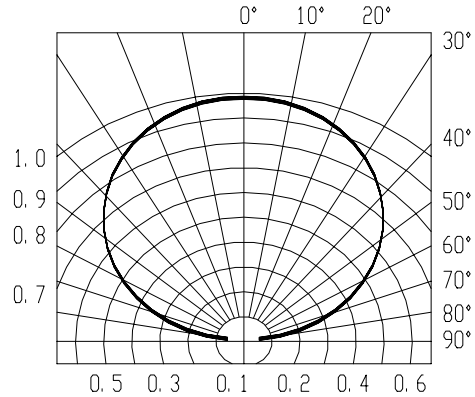

■ **Soldering heat reliability ( DIP ) :**

Please refer to the following figure :

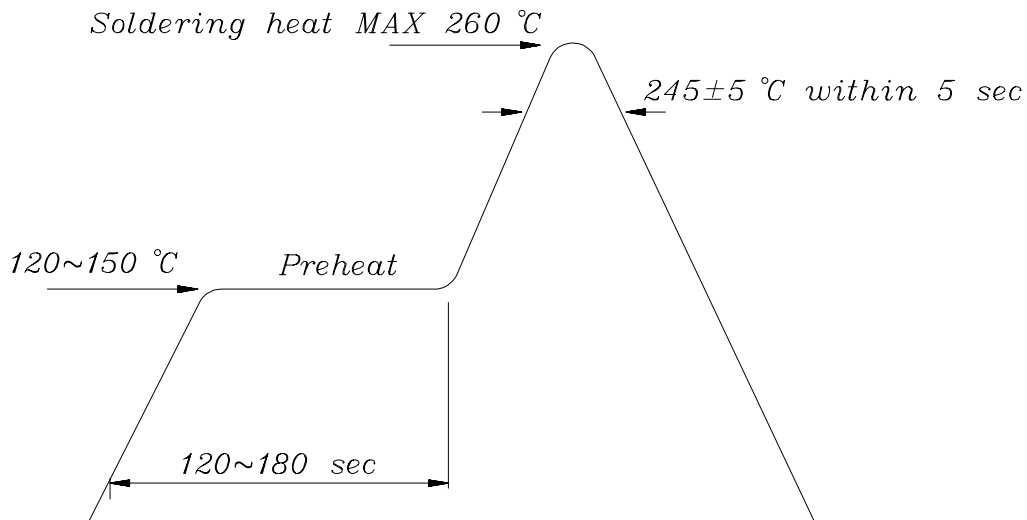

■ **Soldering Iron :**

Basic spec is  $\leq 5$  sec when 260°C. If temperature is higher, time should be shorter (+10°C → -1sec). Power dissipation of Iron should be smaller than 15 W , and temperature should be controllable. Surface temperature of the device should be under 230 °C.

■ **Rework :**

- 1. Customer must finish rework within 5 sec under 245°C.
- 2. The head of iron can not touch copper foil.
- 3. Twin-head type is preferred.

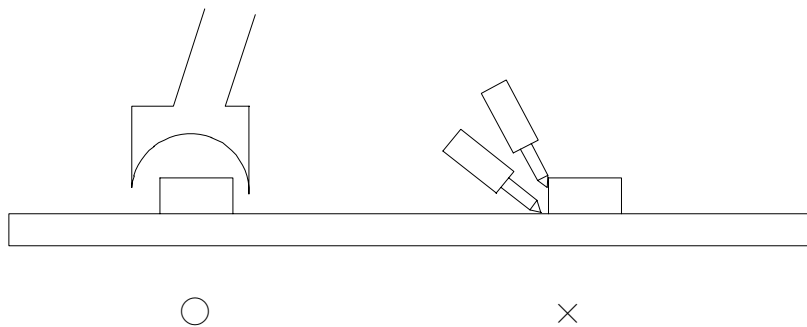





MODEL NO: 67-22SRUGC/TR8

Device Number : DSE-672-005 REV. 1.2

**TOP LED**

ECN : ..... Page: 9/9

■ Reflow Temp. / Time :

