



Technical Data Sheet

TOP LEDs

67-21 VRC/S41/TR8

Features

- P-LCC-2 package.
- White package.
- Optical indicator.
- Colorless clear window.
- Wide viewing angle.
- Suitable for vapor-phase reflow, Infrared reflow and wave solder processes.
- Computable with automatic placement equipment.
- Available on tape and reel (8mm Tape).

Descriptions

- The 67-21 series is available in soft orange, green, blue and yellow. Due to the package design, the LED has wide viewing angle and optimized light coupling by inter reflector. This feature makes the SMT TOP LED ideal for light pipe application. The low current requirement makes this device ideal for portable equipment or any other application where power is at a premium.

Applications

- Automotive: backlighting in dashboard and switch.
- Telecommunication: indicator and backlighting in telephone and fax.
- Flat backlight for LCD, switch and symbol.
- Light pipe application.
- General use.

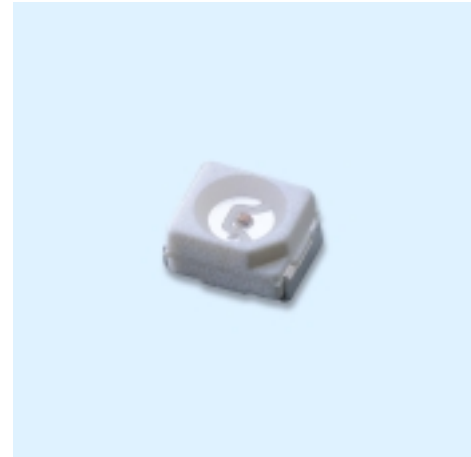

Device Selection Guide

Chip		Lens Color
Material	Emitted Color	
GaAsP/GaP	Hi-Eff Red	Water Clear

Package Dimensions

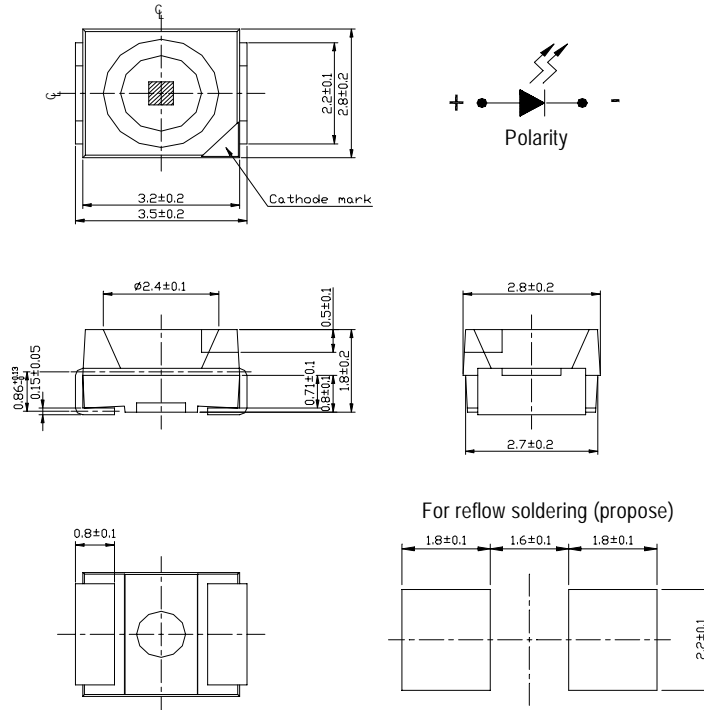

Notes: All dimensions are in millimeters.

Absolute Maximum Ratings (Ta=25°C)

Parameter	Symbol	Rating	Unit
Reverse Voltage	V _R	5	V
Forward Current	I _F	30	mA
Operating Temperature	T _{opr}	-40 ~ +85	°C
Storage Temperature	T _{stg}	-40~ +100	°C
Soldering Temperature	T _{sol}	260 (for 5 second)	°C
Power Dissipation	P _d	100	mW
Peak Forward Current(Duty 1/10 @ 1KHz)	I _{F(Peak)}	160	mA

Electro-Optical Characteristics (Ta=25°C)

Parameter	Symbol	Min.	Typ.	Max.	Unit	Condition
Luminous Intensity	I _v	0.25	0.85	-----	mcd	I _F =2mA
Viewing Angle	2θ 1/2	-----	120	-----	deg	I _F =20mA
Peak Wavelength	λ _p	-----	640	-----	nm	I _F =20mA
Dominant Wavelength	λ _d	-----	625	-----	nm	I _F =20mA
Spectrum Radiation Bandwidth	Δλ	-----	45	-----	nm	I _F =20mA
Forward Voltage	V _F	1.7	2.0	2.4	V	I _F =20mA
Reverse Current	I _R	-----	-----	10	mA	V _R =5V

Package Dimensions

Loaded quantity per reel 2000 PCS/reel

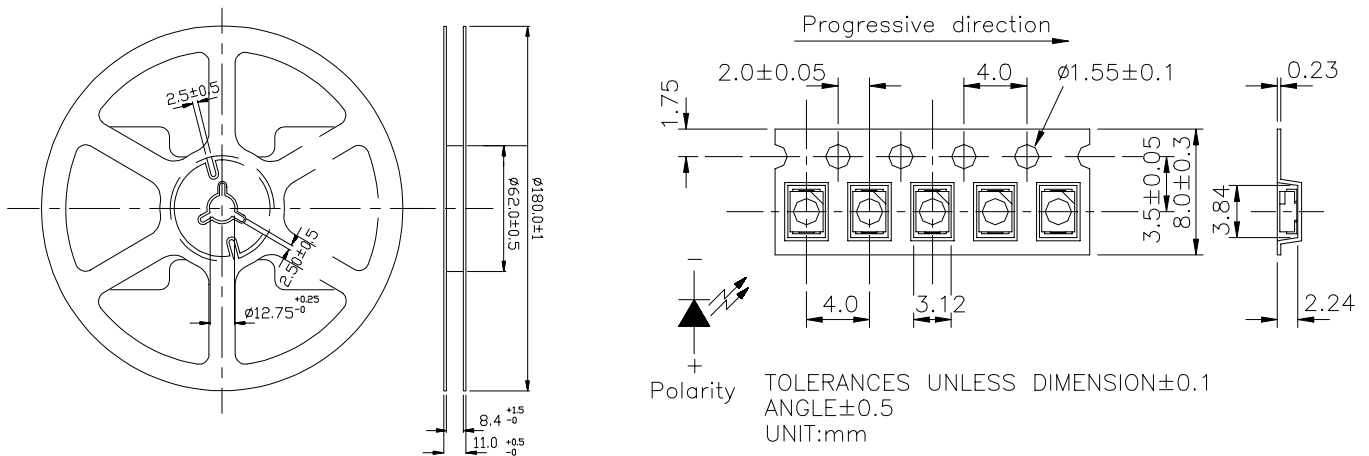

Typical Electro-Optical Characteristics Curves

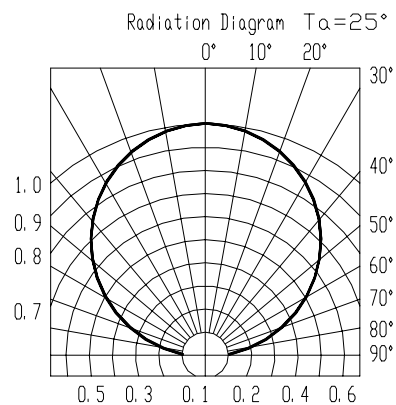
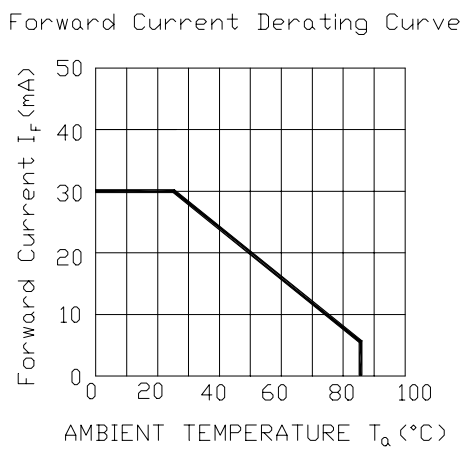
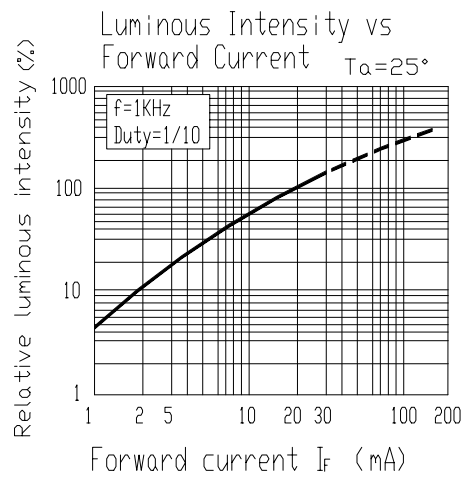
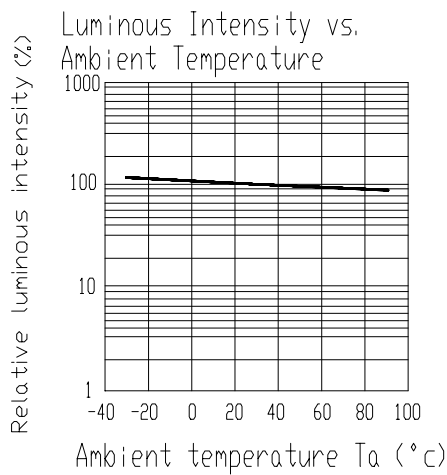
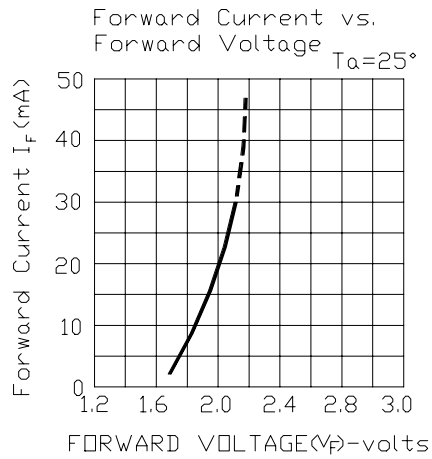
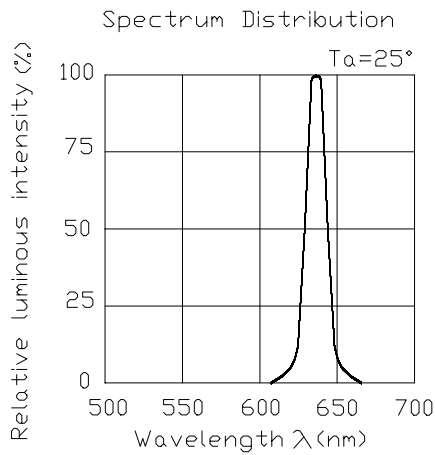

Precautions For Use

1. Over-current-proof

Customer must apply resistors for protection , otherwise slight voltage shift will cause big current change (Burn out will happen).

2. Storage time

2.1 The operation of Temperature and RH are : 5°C~35°C, RH60%.

2.2 Once the package is opened, the products should be used within a week.

Otherwise, they should be kept in a damp proof box with descanting agent.

Considering the tape life , we suggest our customers to use our products within a year(from production date).

2.3 If opened more than one week in an atmosphere 5°C~35°C, RH 60%, they should be treated at 60°C ± 5°C for 12hrs.

2.4 When you discover that the desiccant in the package has a pink color (Normal = blue) , you should treat them in the same conditions as 2.3.

Soldering heat reliability (DIP)

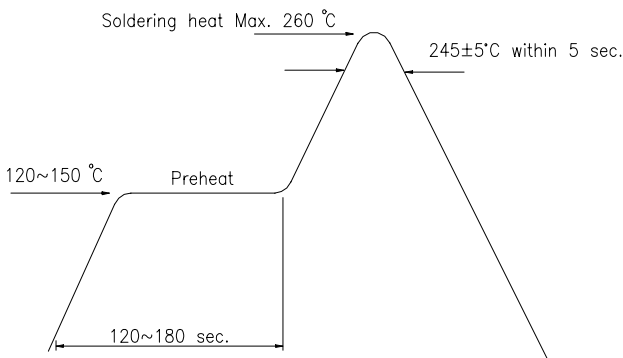

Reflow Temp. / Time

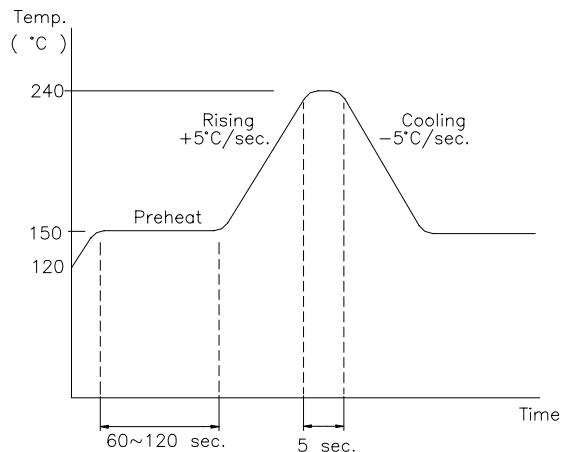

Soldering Iron

Basic spec is ≤ 5 sec when 245°C. If temperature is higher, time should be shorter (+10°C → - 1sec). Power dissipation of Iron should be smaller than 15 W , and temperature should be controllable. Surface temperature of the device should be under 230 °C.

Rework

1. Customer must finish rework within 5 sec under 245°C.
2. The head of iron can not touch copper foil.
3. Twin-head type is preferred.

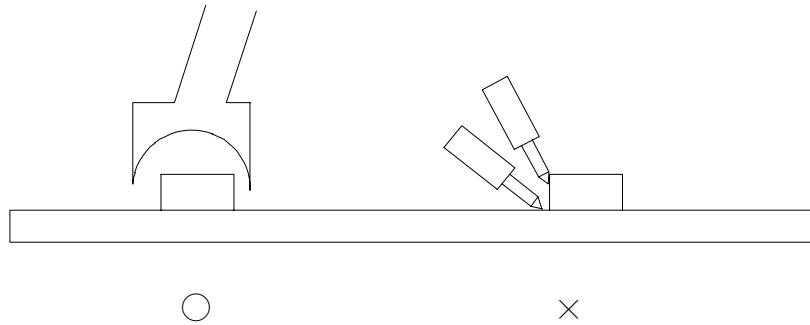

EVERLIGHT ELECTRONICS CO., LTD.
Office: No 25, Lane 76, Sec 3, Chung Yang Rd,
Tucheng, Taipei 236, Taiwan, R.O.C

Tel: 886-2-2267-2000, 2267-9936
Fax: 886-2267-6244, 2267-6189, 2267-6306
<http://www.everlight.com>