



## Technical Data Sheet

### TOP View LEDs With Lens

#### 67-21B/G6C-BR1S2B/BT

#### Features

- P-LCC-2 package.
- High flux output.
- High current capability.
- White package.
- Optical indicator.
- Colorless clear window.
- Ideal for backlight and light pipe application.
- Inter reflector.
- Suitable for automatic placement equipment.
- Suitable for reflow and wave solder processes.
- Available on tape and reel (12mm Tape).
- Pb-free.
- The product itself will remain within RoHS compliant version.

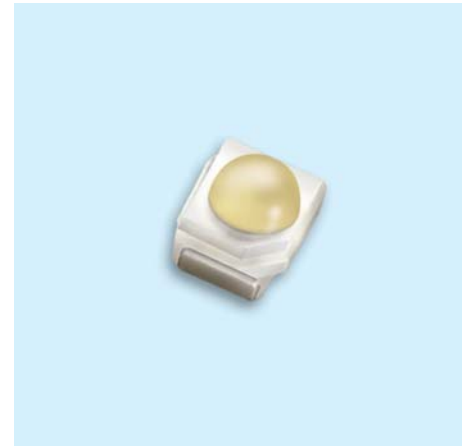

#### Descriptions

- The 67-21B series is available in soft orange, green, blue and yellow. Due to the package design, the LED has wide viewing angle and optimized light coupling by inter reflector. This feature makes the ideal for light pipe application. The low current requirement makes this device ideal for portable equipment or any other application where power is at a premium.

#### Applications

- Telecommunication: indicator and backlighting in telephone and fax.
- Flat backlight for LCD, switch and symbol.
- Light pipe application.
- General use.

#### Device Selection Guide

Chip	Emitted Color	Lens Color
Material		
AlGaInP	Brilliant Yellow Green	Water Clear

**Package Dimensions**

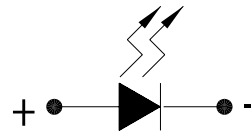
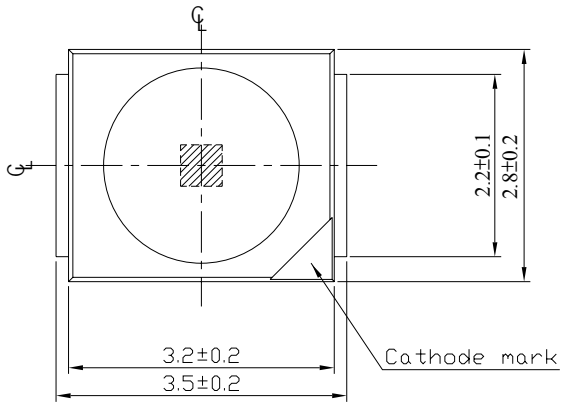

Polarity

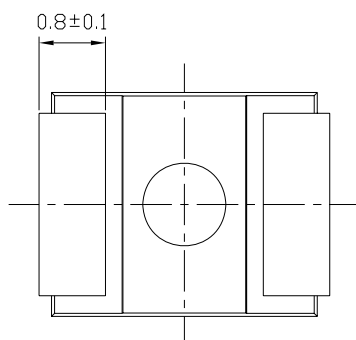
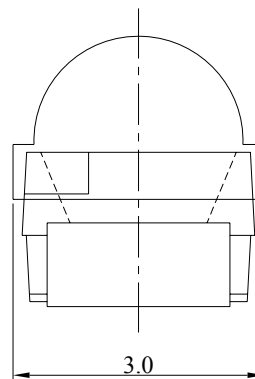
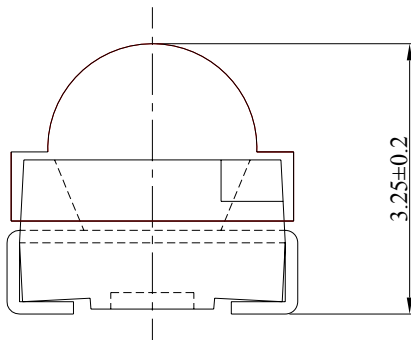

For reflow soldering (propose)

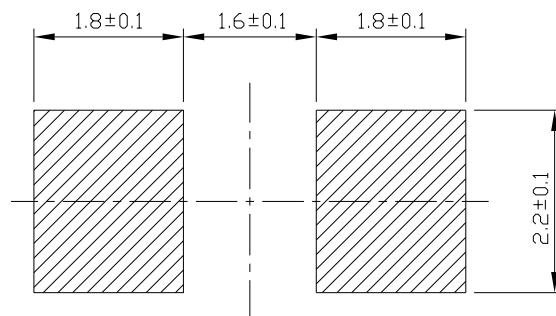

**Notes:** Tolerances Unless Dimension  $\pm 0.1$ mm, Unit = mm

**Absolute Maximum Ratings ( $T_a=25^{\circ}\text{C}$ )**

Parameter	Symbol	Rating	Unit
Reverse Voltage	$V_R$	5	V
Forward Current	$I_F$	25	mA
Peak Forward Current (Duty 1/10 @1KHz)	$I_{FP}$	60	mA
Power Dissipation	$P_d$	60	mW
Electrostatic Discharge(HBM)	ESD	2000	V
Operating Temperature	$T_{opr}$	-40 ~ +85	$^{\circ}\text{C}$
Storage Temperature	$T_{stg}$	-40 ~ +90	$^{\circ}\text{C}$
Soldering Temperature	$T_{sol}$	Reflow Soldering : 260 $^{\circ}\text{C}$ for 10 sec. Hand Soldering : 350 $^{\circ}\text{C}$ for 3 sec.	

**Electronic Optical Characteristics ( $T_a=25^{\circ}\text{C}$ ) :**

Parameter	Symbol	Min.	Typ.	Max.	Unit	Condition
Luminous Intensity	$I_v$	112	-----	285	mcd	$I_F=20\text{mA}$
Viewing Angle	$2\theta_{1/2}$	-----	60	-----	deg	$I_F=20\text{mA}$
Peak Wavelength	$\lambda_p$	-----	575	-----	nm	$I_F=20\text{mA}$
Dominant Wavelength	$\lambda_d$	567.5	-----	575.5	nm	$I_F=20\text{mA}$
Spectrum Radiation Bandwidth	$\Delta\lambda$	-----	20	-----	nm	$I_F=20\text{mA}$
Forward Voltage	$V_F$	1.75	-----	2.35	V	$I_F=20\text{mA}$
Reverse Current	$I_R$	-----	-----	10	$\mu\text{A}$	$V_R=5\text{V}$

Notes:

- 1.Tolerance of Dominant Wavelength:  $\pm 1\text{nm}$
- 2.Tolerance of Luminous Intensity:  $\pm 11\%$
- 3.Tolerance of Forward Voltage:  $\pm 0.05\text{V}$

**67-21B/G6C-BR1S2B/BT**
**Bin Range of Dom. Wavelength**

Group	Bin Code	Min	Max	Unit	Condition
B	C15	567.5	569.5	nm	I <sub>F</sub> =20mA
	C16	569.5	571.5		
	C17	571.5	573.5		
	C18	573.5	575.5		

**Bin Range of Luminous Intensity**

Bin Code	Min.	Max.	Unit	Conduction
R1	112	140	mcd	I <sub>F</sub> =20mA
R2	140	180		
S1	180	225		
S2	225	285		

**Bin Range of Forward Voltage**

Group	Bin	Min	Max	Unit	Condition
B	0	1.75	1.95	V	IF=20mA
	1	1.95	2.15		
	2	2.15	2.35		

**Notes:**

- 1.Tolerance of Dominant Wavelength:  $\pm 1$ nm
- 2.Tolerance of Luminous Intensity:  $\pm 11\%$
- 3.Tolerance of Forward Voltage:  $\pm 0.05$ V

**Typical Electro-Optical Characteristics Curves**

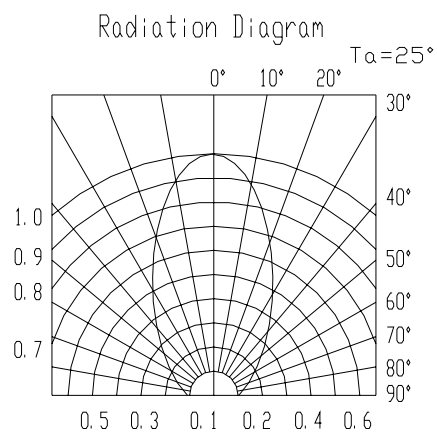
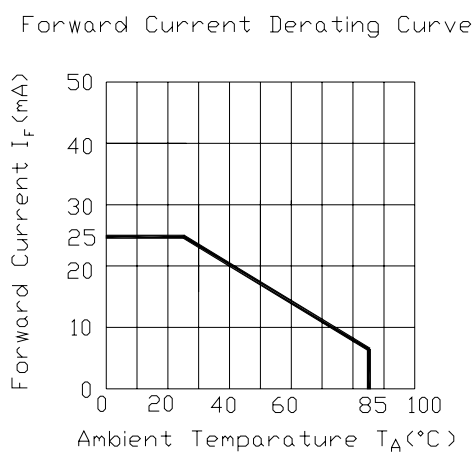
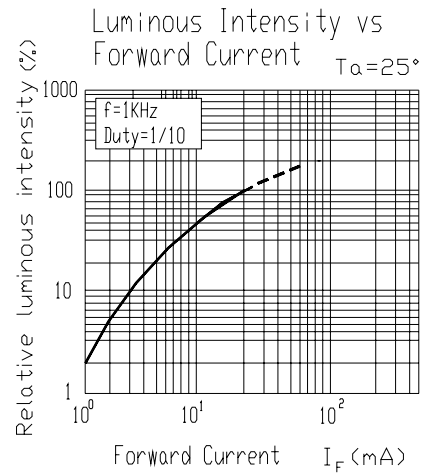
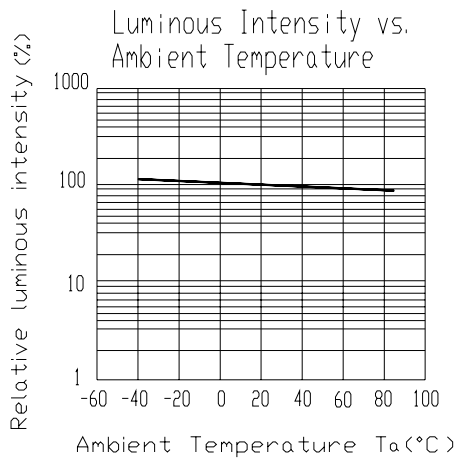
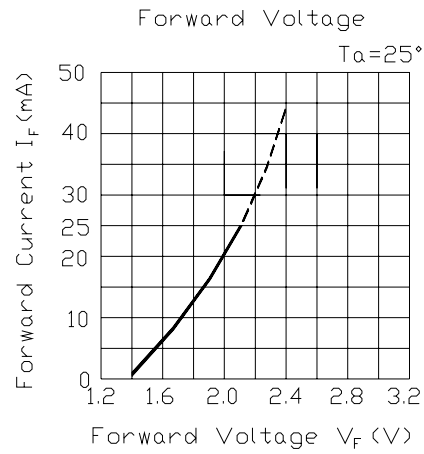
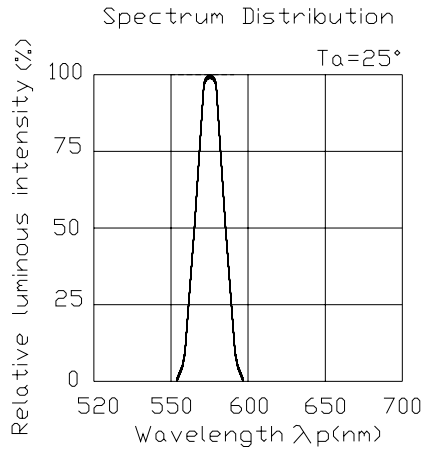

**67-21B/G6C-BR1S2B/BT**

**Label explanation**

**CAT: Luminous Intensity Rank**

**HUE: Dom. Wavelength Rank**

**REF: Forward Voltage Rank**

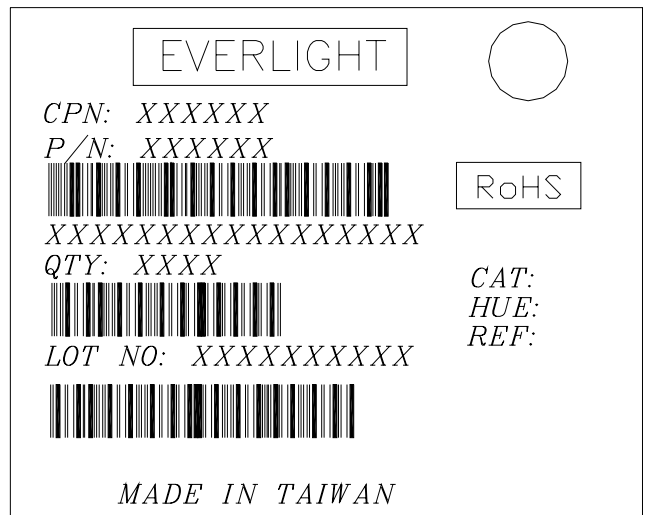

**Reel Dimensions**

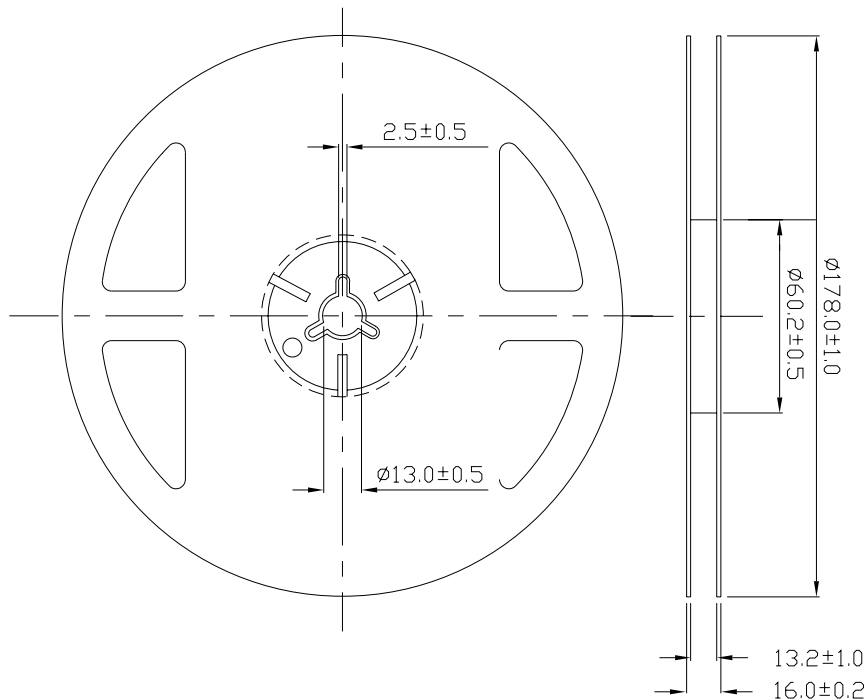

**Note:** The tolerances unless mentioned is  $\pm 0.1$ mm ,Unit = mm

**Carrier Tape Dimensions: Loaded quantity 500 PCS per reel.**

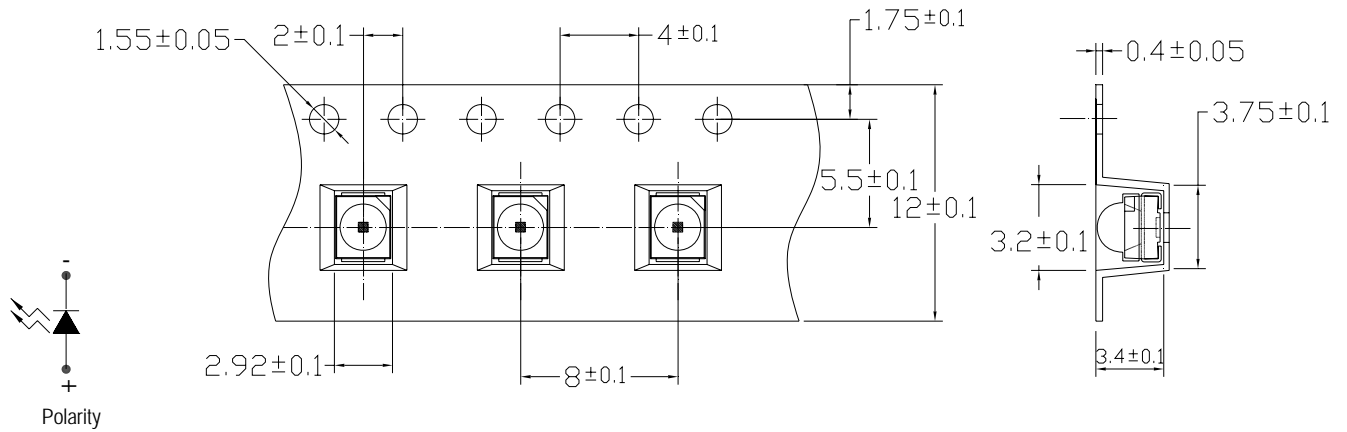

**Note:** The tolerances unless mentioned is  $\pm 0.1$ mm Unit = mm

**Moisture Resistant Packaging**

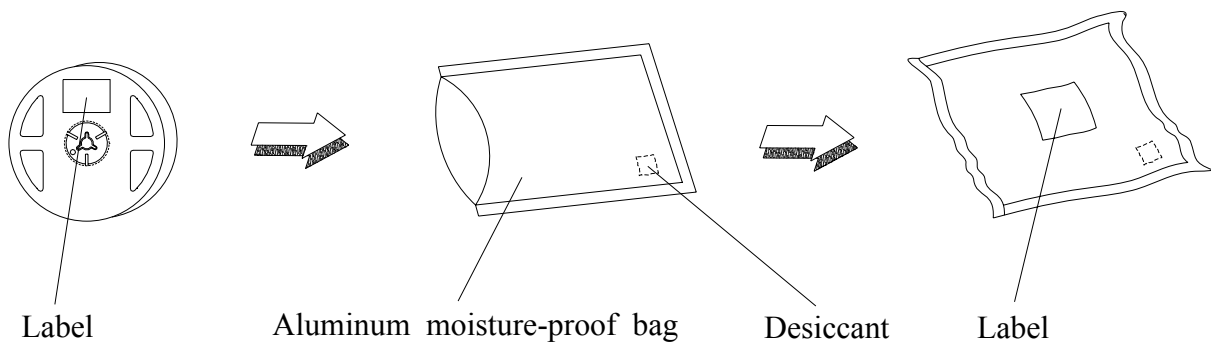

**Reliability Test Items And Conditions**

The reliability of products shall be satisfied with items listed below.

Confidence level : 90%

LTPD : 10%

No.	Items	Test Condition	Test Hours/Cycles	Sample Size	Ac/Re
1	Reflow Soldering	Temp. : 260°C±5°C Min. 5sec.	6 Min.	22 PCS.	0/1
2	Temperature Cycle	H : +100°C 15min ∫ 5 min L : -40°C 15min	300 Cycles	22 PCS.	0/1
3	Thermal Shock	H : +100°C 5min ∫ 10 sec L : -10°C 5min	300 Cycles	22 PCS.	0/1
4	High Temperature Storage	Temp. : 100°C	1000 Hrs.	22 PCS.	0/1
5	Low Temperature Storage	Temp. : -40°C	1000 Hrs.	22 PCS.	0/1
6	DC Operating Life	IF = 20 mA	1000 Hrs.	22 PCS.	0/1
7	High Temperature / High Humidity	85°C/ 85%RH	1000 Hrs.	22 PCS.	0/1



**Precautions For Use**
**1. Over-current-proof**

Customer must apply resistors for protection, otherwise slight voltage shift will cause big current change ( Burn out will happen ).

**2. Storage**

2.1 Do not open moisture proof bag before the products are ready to use.

2.2 Before opening the package: The LEDs should be kept at 30°C or less and 90%RH or less.

2.3 After opening the package: The LED's floor life is 1 year under 30°C or less and 60% RH or less.

If unused LEDs remain, it should be stored in moisture proof packages.

2.4 If the moisture absorbent material (silica gel) has faded away or the LEDs have exceeded the storage time, baking treatment should be performed using the following conditions.

Baking treatment : 60±5°C for 24 hours.

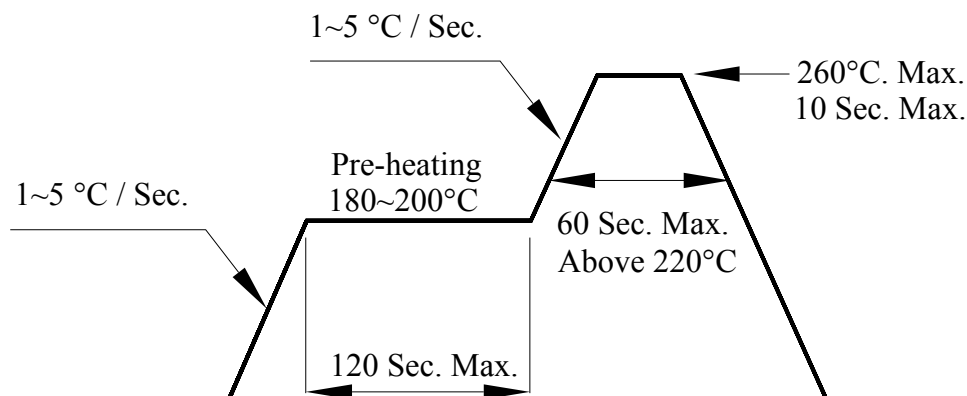
**3. Soldering Condition**
**3.1 Pb-free solder temperature profile**

3.2 Reflow soldering should not be done more than two times.

3.3 When soldering, do not put stress on the LEDs during heating.

3.4 After soldering, do not warp the circuit board.

**4. Soldering Iron**

Each terminal is to go to the tip of soldering iron temperature less than 350°C for 3 seconds within once in less than the soldering iron capacity 25W. Leave two seconds and more intervals, and do soldering of each terminal. Be careful because the damage of the product is often started at the time of the hand solder.

### 5.Repairing

Repair should not be done after the LEDs have been soldered. When repairing is unavoidable, a double-head soldering iron should be used (as below figure). It should be confirmed beforehand whether the characteristics of the LEDs will or will not be damaged by repairing.

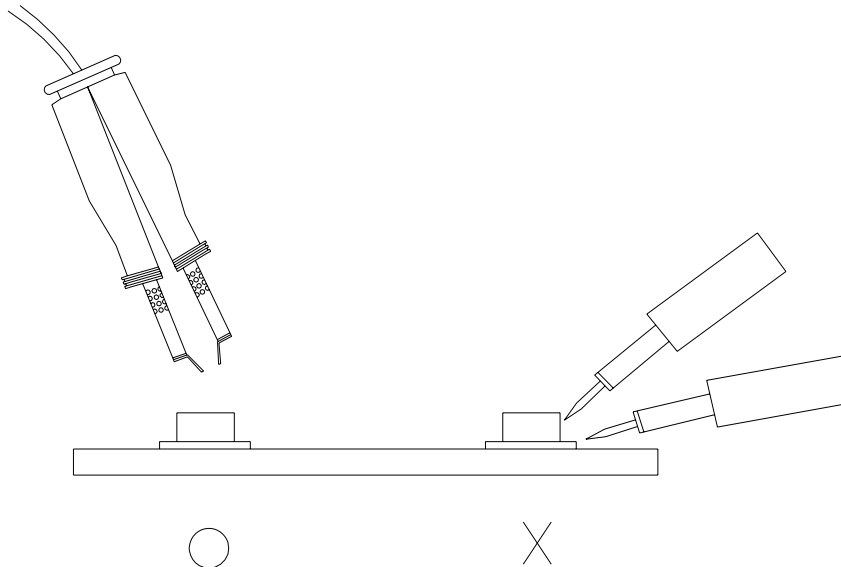

**EVERLIGHT ELECTRONICS CO., LTD.**  
Office: No 25, Lane 76, Sec 3, Chung Yang Rd,  
Tucheng, Taipei 236, Taiwan, R.O.C

Tel: 886-2-2267-2000, 2267-9936  
Fax: 886-2267-6244, 2267-6189, 2267-6306  
<http://www.everlight.com>