



EVERLIGHT ELECTRONICS CO., LTD.

DATA SHEET

Part No. : 64-335/REGBB7C-B04/2T

Date : 2007.08.01

Department : RD3

Revision : 1.1

Received	
<input type="checkbox"/>	MASS PRODUCTION
<input checked="" type="checkbox"/>	PRELIMINARY
<input type="checkbox"/>	CUSTOMER DESIGN
PAGE : 14	

Revised record		
REV.	DESCRIPTION	RELEASE DATE
1.1	New Spec.	2007.8.1

OFFICE:..NO.25,LANE76,SEC.3,CHUNG YANG RD.,TUCHENG 236,TAIPEI,TAIWAN,R.O.C

TEL : 886-2-22672000

FAX : 886-2-22676244

<http://www.everlight.com>



Technical Data Sheet – Preliminary

Luminosity Full Color LED

64-335/REGHB7C-B04/2T

Features

- Super-luminosity chip LED.
- White SMT package.
- Built in Red, Green, and Blue chips.
- Lead frame package with individual 6 pins.
- Wide viewing angle.
- Soldering methods: IR reflow soldering.
- Pb-free.
- The product itself will remain within RoHS compliant version.



Descriptions

- Due to the package design, 64-335 has wide viewing angle , low power consumption and adjusting each color is possible thanks to serial connection by 6 terminal connection (Individual driving by each terminal) in case of using several number of LED, and makes it ideal for light pipe application.

Applications

- Amusement equipment.
- Information boards.
- Flashlight for digital camera of cellular phone.
- Telecommunication: indicator and backlighting in telephone and fax.
- Flat backlight for LCD's, switches and symbols.
- Light pipe application.
- General use.

Device Selection Guide

Chip		Emitted Color	Resin Color
Type	Material		
RE	AlGaInP	Brilliant Red	Water Clear
GB	InGaN	Brilliant Green	
B7	InGaN	Blue	



Technical Data Sheet – Preliminary

Luminosity Full Color LED

64-335/REGBB7C-B04/2T

Package Outline Dimensions

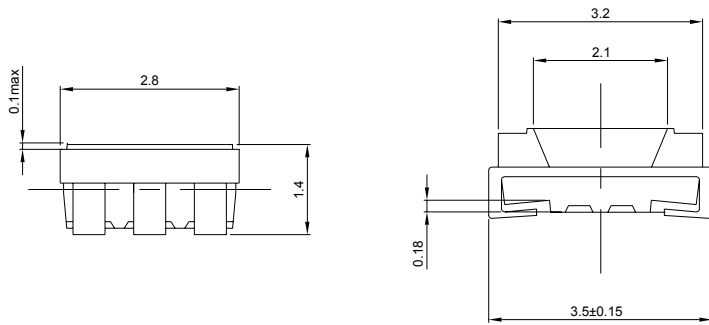
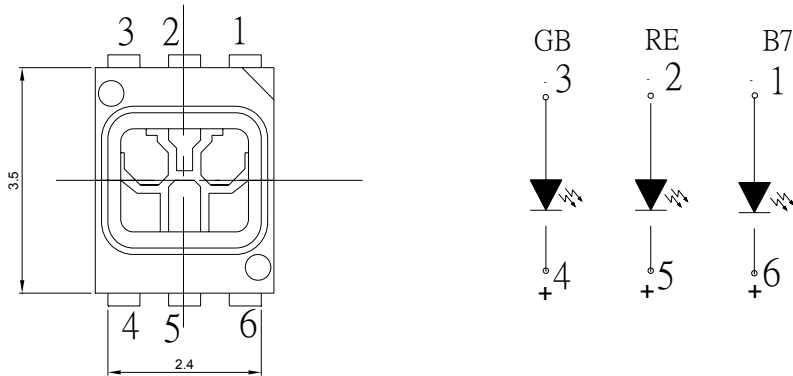

For reflow solder (Proposal)

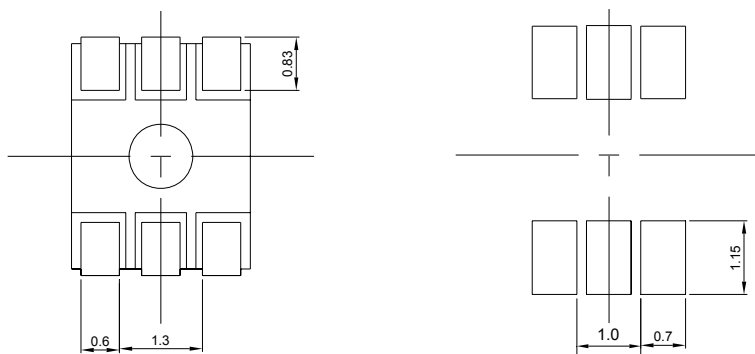

Note: The tolerances unless mentioned is $\pm 0.1\text{mm}$; Unit = mm



Technical Data Sheet – Preliminary

Luminosity Full Color LED

64-335/REGBB7C-B04/2T

Absolute Maximum Ratings (Ta=25°C)

Parameter	Symbol	Rating	Unit
Reverse Voltage	V _R	5	V
Forward Current	I _F	RE	50
		GB	30
		B7	30
Peak Forward Current(Duty 1/10 @ 1KHz)	I _{FP}	RE	100
		GB	100
		B7	100
Power Dissipation	Pd	RE	120
		GB	110
		B7	110
Electrostatic Discharge(HBM)	ESD	RE	2000
		GB	150
		B7	150
Operating Temperature	Topr	-40 ~ +85	°C
Storage Temperature	Tstg	-40~ +90	°C
Soldering Temperature	Tsol	Reflow Soldering : 260 °C for 10 sec. Hand Soldering : 350 °C for 3 sec.	



Technical Data Sheet – Preliminary

Luminosity Full Color LED

64-335/REGBB7C-B04/2T

Electro-Optical Characteristics (Ta=25°C)

Parameter	Symbol	Min.	Typ.	Max.	Unit	Condition	
Luminous Intensity	I _v	RE	360	-----	715	mcd	I _F =20mA
		GB	565	-----	1120		
		B7	180	-----	450		
Viewing Angle	2θ 1/2	-----	120	-----	deg	I _F =20mA	
Peak Wavelength	λ _p	RE	-----	632	-----	nm	I _F =20mA
		GB	-----	518	-----		
		B7	-----	468	-----		
Dominant Wavelength	λ _d	RE	617.5	-----	625.5	nm	I _F =20mA
		GB	519.5	-----	531.5		
		B7	467.5	-----	476.5		
Spectrum Radiation Bandwidth	Δλ	RE	-----	20	-----	nm	I _F =20mA
		GB	-----	35	-----		
		B7	-----	35	-----		
Forward Voltage	V _F	RE	1.75	-----	2.35	V	I _F =20mA
		GB	2.75	-----	3.95		
		B7	2.75	-----	3.95		
Reverse Current	I _R	RE	-----	-----	10	μA	V _R =5V
		GB	-----	-----	50		
		B7	-----	-----	50		

Notes:

1. Tolerance of Luminous Intensity: ±11%
2. Tolerance of Dominant Wavelength: ±1 nm
3. Tolerance of Forward Voltage: ±0.1V



Technical Data Sheet – Preliminary

Luminosity Full Color LED

64-335/REGBB7C-B04/2T**Bin Range of Luminous Intensity**

Symbol		Bin Code	Min.	Max.	Unit	Condition
I _v	RE	T2	360	450	mcd	I _F =20mA
		U1	450	565		
		U2	565	715		
	GB	U2	565	715		
		V1	715	900		
		V2	900	1120		
	B7	S1	180	225		
		S2	225	285		
		T1	285	360		
		T2	360	450		

Bin Range of Dominant Wavelength

Symbol		Bin Code	Min.	Max.	Unit	Condition
λ _d	RE	E1	617.5	621.5	nm	I _F =20mA
		E2	621.5	625.5		
	GB	B11	519.5	521.5		
		B12	521.5	523.5		
		B13	523.5	525.5		
		B14	525.5	527.5		
		B15	527.5	529.5		
		B16	529.5	531.5		
	B7	A9	464.5	467.5		
		A10	467.5	470.5		
		A11	470.5	473.5		
		A12	473.5	476.5		

Notes:

1. Tolerance of Luminous Intensity: ±11%
2. Tolerance of Dominant Wavelength: ±1 nm



Technical Data Sheet – Preliminary

Luminosity Full Color LED

64-335/REGBB7C-B04/2T

Bin Range of Forward Voltage

Symbol	Bin Code	Min.	Max.	Unit	Condition
V _F	RE	R1	1.75	2.35	V I _F =20mA
	GB	G1	2.75	3.95	
	B7	B1	2.75	3.95	

Notes:

1. Tolerance of Forward Voltage: $\pm 0.1V$



Technical Data Sheet – Preliminary

Luminosity Full Color LED

64-335/REGBB7C-B04/2T

Typical Electro-Optical Characteristics Curves (RE)

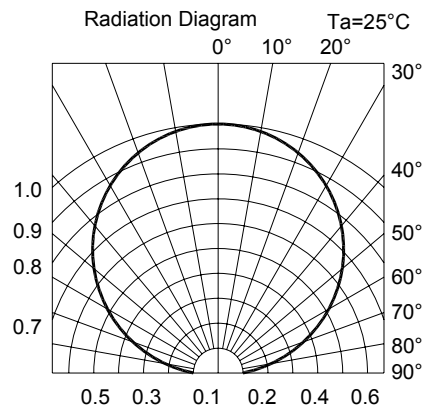
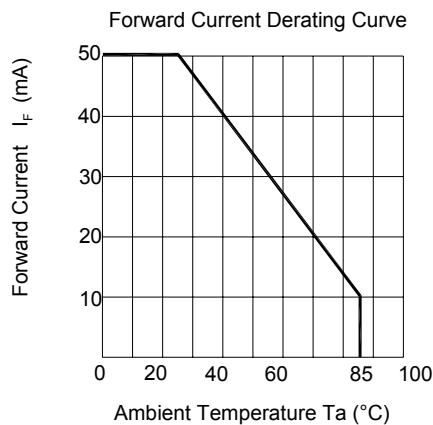
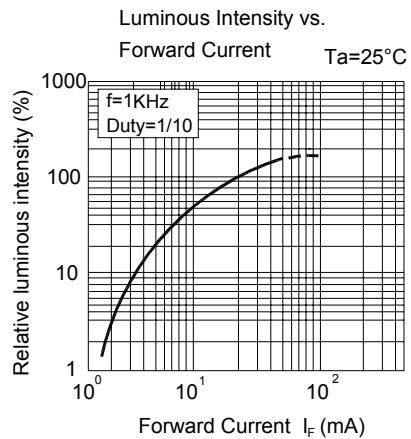
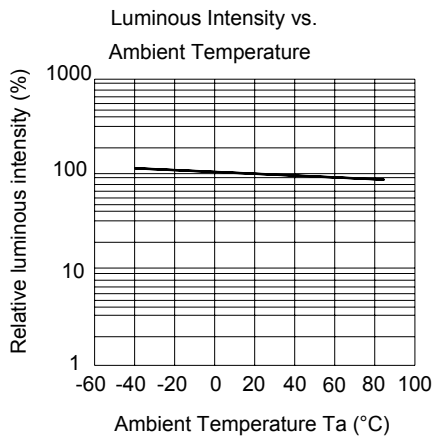
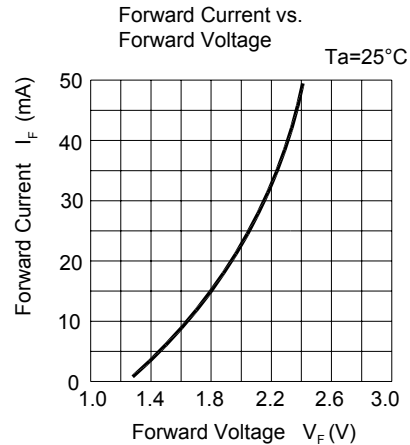
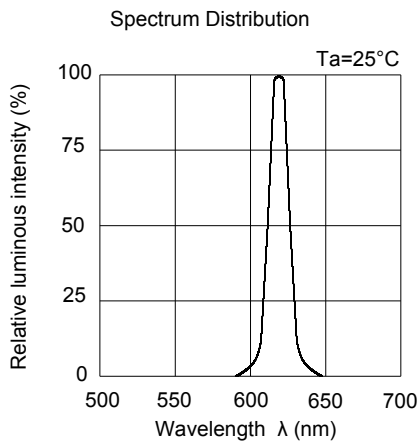



Technical Data Sheet – Preliminary

Luminosity Full Color LED

64-335/REGBB7C-B04/2T

Typical Electro-Optical Characteristics Curves (GB)

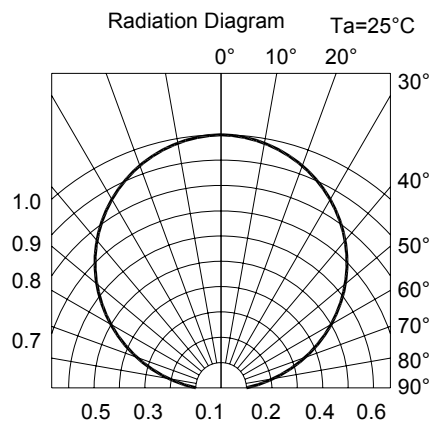
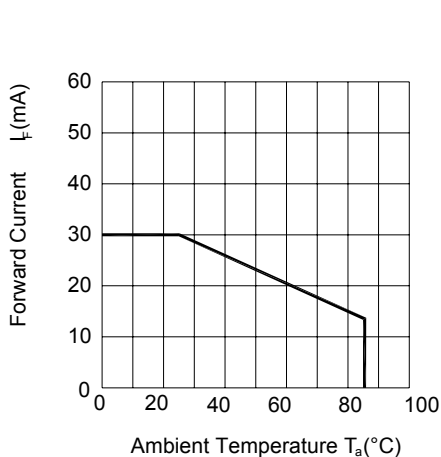
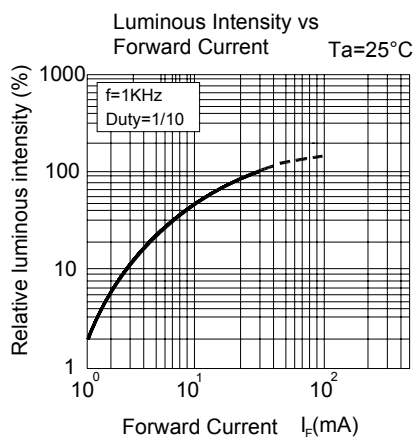
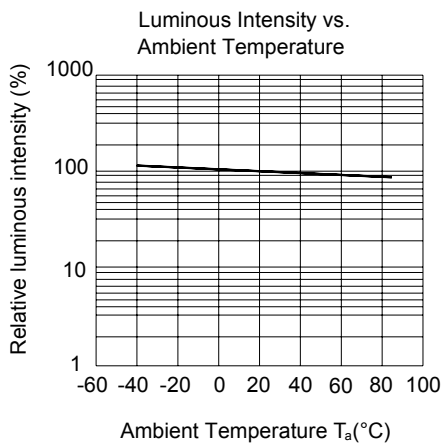
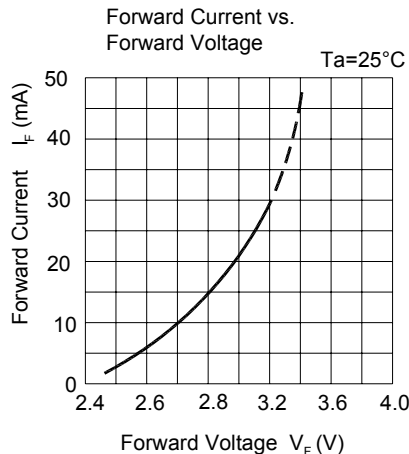
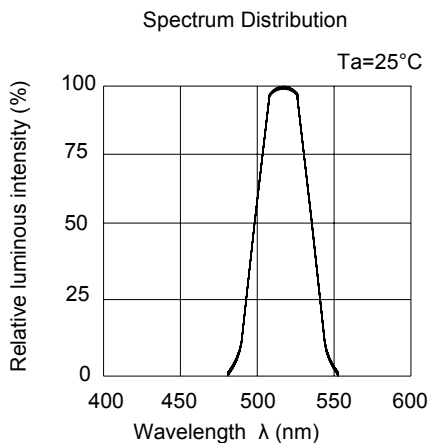



Technical Data Sheet – Preliminary

Luminosity Full Color LED

64-335/REGBB7C-B04/2T

Typical Electro-Optical Characteristics Curves (B7)

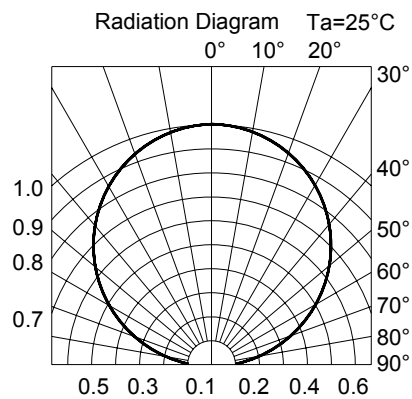
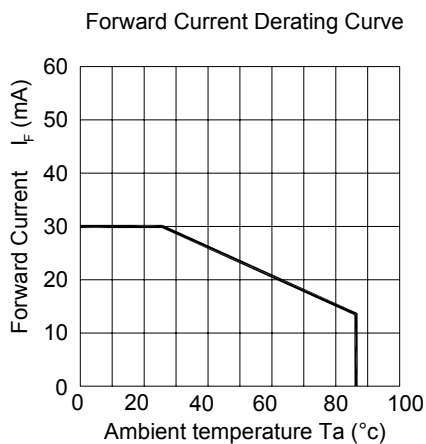
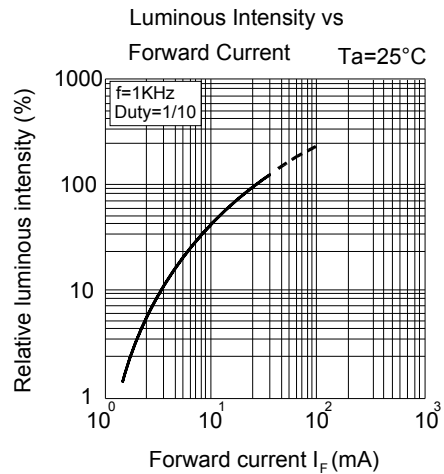
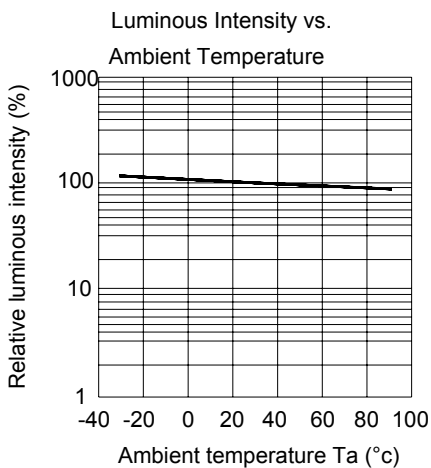
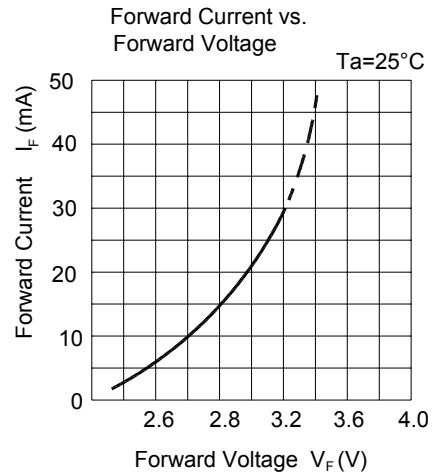
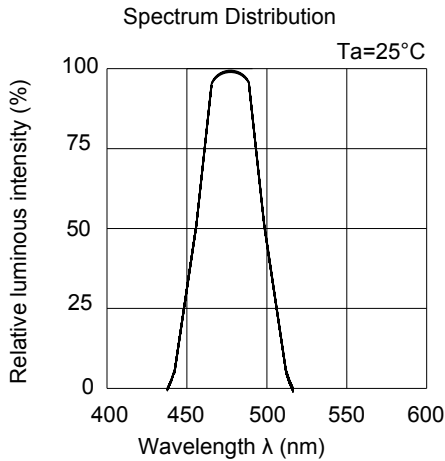



Technical Data Sheet – Preliminary

Luminosity Full Color LED

64-335/REGBB7C-B04/2T

Label explanation

CAT: Luminous Intensity Rank

HUE: Dom. Wavelength Rank

REF: Forward Voltage Rank

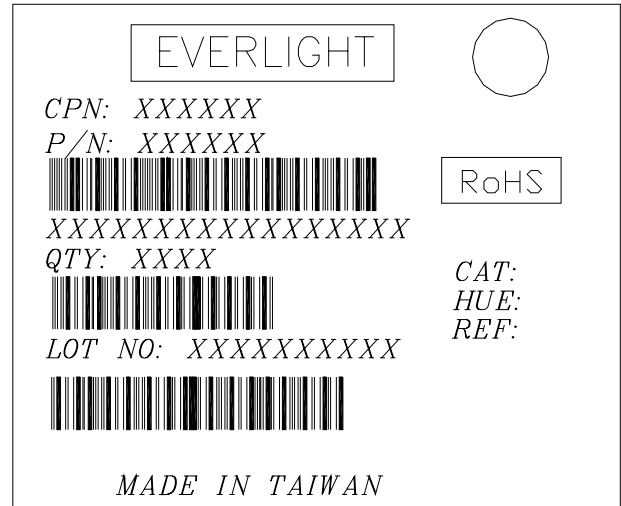

Reel Dimensions

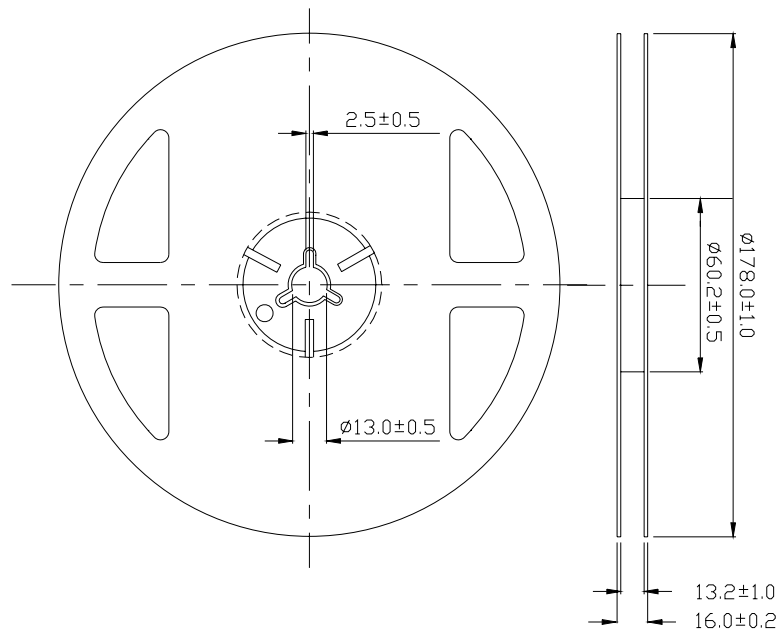

Note: The tolerances unless mentioned is $\pm 0.1\text{mm}$, Unit = mm



Technical Data Sheet – Preliminary

Luminosity Full Color LED

64-335/REGBB7C-B04/2T

Carrier Tape Dimensions: Loaded quantity 2000 PCS per reel.

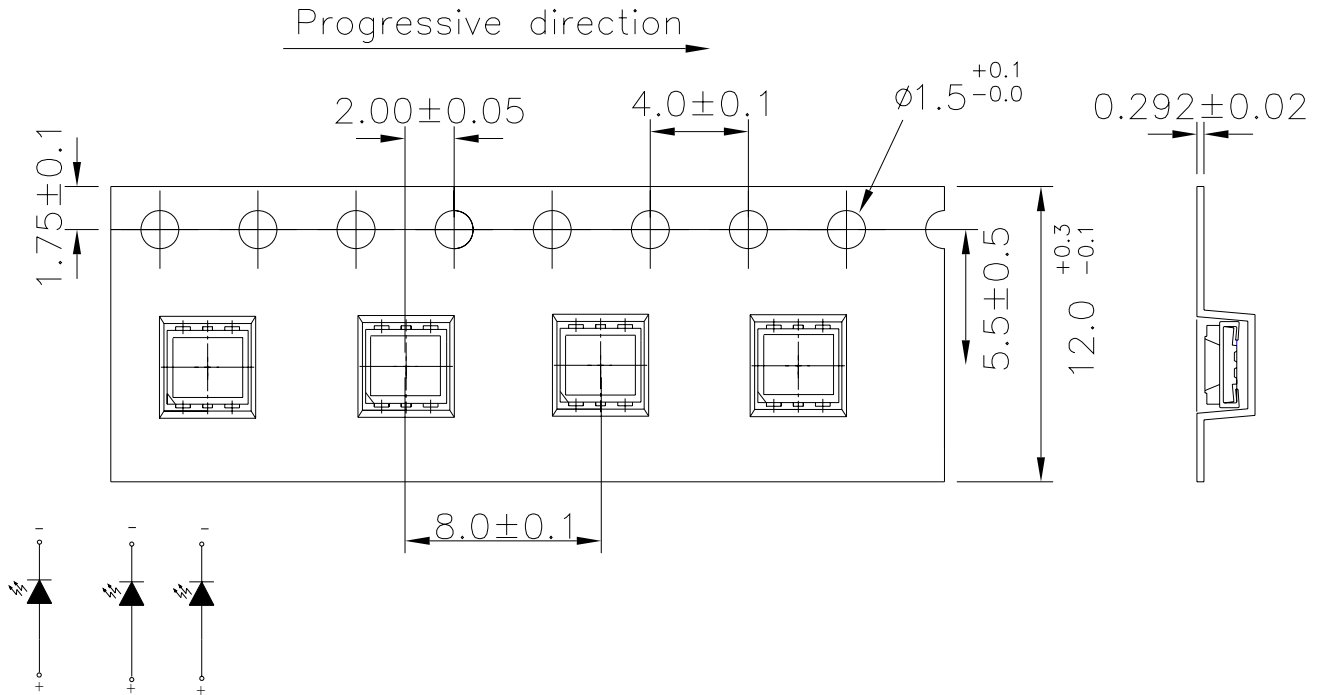

Moisture Resistant Packaging

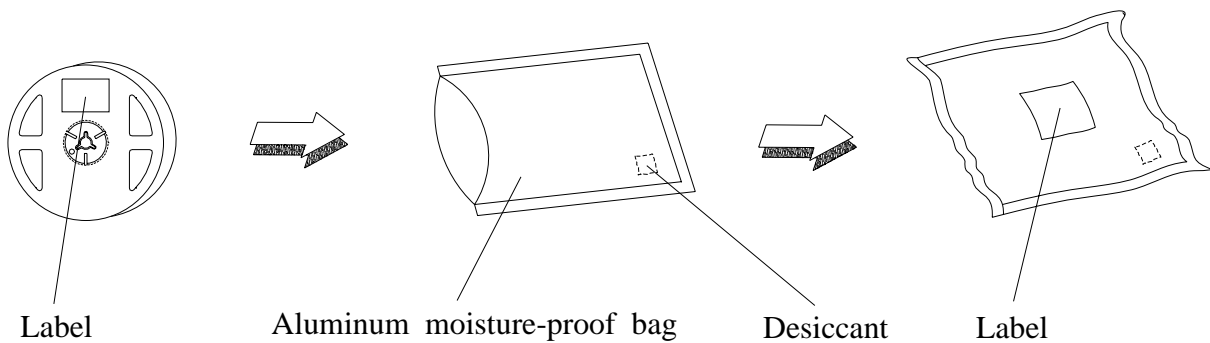

**Technical Data Sheet – Preliminary****Luminosity Full Color LED****64-335/REGBB7C-B04/2T****Reliability Test Items and Conditions**

The reliability of products shall be satisfied with items listed below.

Confidence level : 90%

LTPD : 10%

No.	Items	Test Condition	Test Hours/Cycles	Sample Size	Ac/Re
1	Reflow Soldering	Temp. : 260°C±5°C Min. 5sec.	6 Min.	22 PCS.	0/1
2	Temperature Cycle	H : +100°C 15min ∫ 5 min L : -40°C 15min	300 Cycles	22 PCS.	0/1
3	Thermal Shock	H : +100°C 5min ∫ 10 sec L : -10°C 5min	300 Cycles	22 PCS.	0/1
4	High Temperature Storage	Temp. : 100°C	1000 Hrs.	22 PCS.	0/1
5	Low Temperature Storage	Temp. : -40°C	1000 Hrs.	22 PCS.	0/1
6	DC Operating Life	I _F = 20 mA	1000 Hrs.	22 PCS.	0/1
7	High Temperature / High Humidity	85°C / 85%RH	1000 Hrs.	22 PCS.	0/1

* For each die

Technical Data Sheet – Preliminary

Luminosity Full Color LED

64-335/REGBB7C-B04/2T

Precautions for Use

1. Over-current-proof

Customer must apply resistors for protection, otherwise slight voltage shift will cause big current change (Burn out will happen).

2. Storage

2.1 Do not open moisture proof bag before the products are ready to use.

2.2 Before opening the package: The LEDs should be kept at 30°C or less and 90%RH or less.

2.3 After opening the package: The LED's floor life is 1 year under 30 deg C or less and 60% RH or less.

If unused LEDs remain, it should be stored in moisture proof packages.

2.4 If the moisture absorbent material (silica gel) has faded away or the LEDs have exceeded the storage time, baking treatment should be performed using the following conditions.

Baking treatment : 60±5°C for 24 hours.

3. Soldering Condition

3.1 Pb-free solder temperature profile

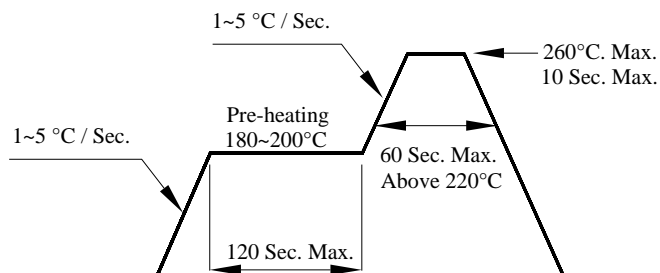

3.2 Reflow soldering should not be done more than two times.

3.3 When soldering, do not put stress on the LEDs during heating.

3.4 After soldering, do not warp the circuit board.

Technical Data Sheet – Preliminary

Luminosity Full Color LED

64-335/REGBB7C-B04/2T

4. Soldering Iron

Each terminal is to go to the tip of soldering iron temperature less than 350°C for 3 seconds within once in less than the soldering iron capacity 25W. Leave two seconds and more intervals, and do soldering of each terminal. Be careful because the damage of the product is often started at the time of the hand solder.

5. Repairing

Repair should not be done after the LEDs have been soldered. When repairing is unavoidable, a double-head soldering iron should be used (as below figure). It should be confirmed beforehand whether the characteristics of the LEDs will or will not be damaged by repairing.

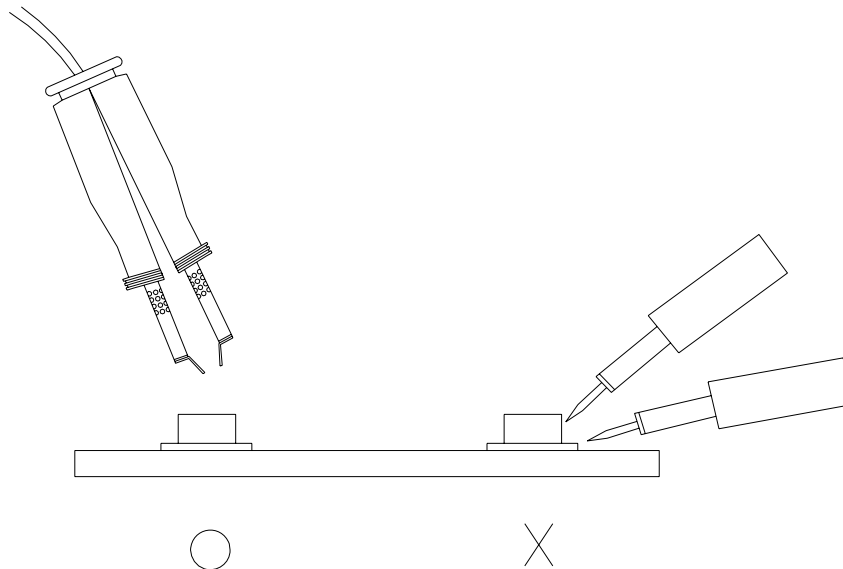

EVERLIGHT ELECTRONICS CO., LTD.
Office: No 25, Lane 76, Sec 3, Chung Yang Rd,
Tucheng, Taipei 236, Taiwan, R.O.C

Tel: 886-2-2267-2000, 2267-9936
Fax: 886-2267-6244, 2267-6189, 2267-6306
<http://www.everlight.com>