

Technical Data Sheet - Preliminary
Luminosity white Color LED

45-11/B7C-AS2U1E/2T

Features

- Top View White LEDs
- Lead frame package with individual 2 pins.
- Wide viewing angle.
- Soldering methods: IR reflow soldering.
- ESD protection.
- Pb-free.
- The product itself will remain within RoHS compliant version.



Descriptions

- Due to the package design, 45-11 has wide viewing angle, low power consumption and white LEDs are devices which are materialized by combing Blue LEDs and special phosphors. This feature makes the LED ideal for light guide application.

Applications

- LCD Back Light.
- Mobile phones .
- Indicators.
- Illuminations.
- Switch Lights.

Device Selection Guide

Chip	Emitted Color	Resin Color
Material		
InGaN	Blue	Water Clear



Technical Data Sheet - Preliminary

Luminosity white Color LED

45-11/B7C-AS2U1E/2T

Package Outline Dimensions

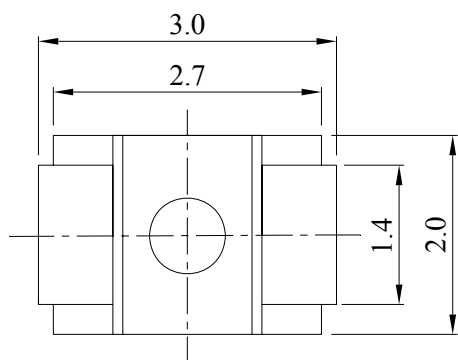
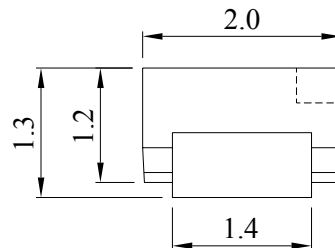
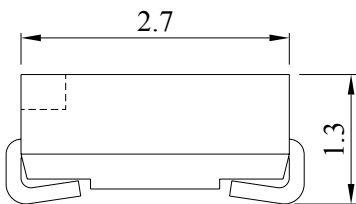
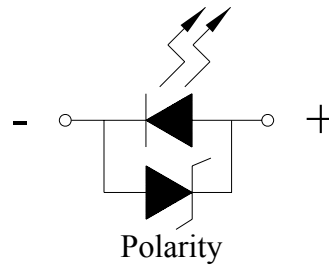
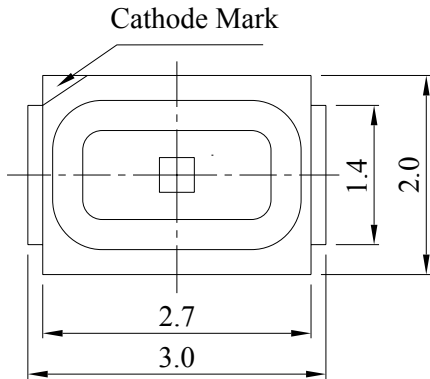

For Reflow Soldering (Proposal)

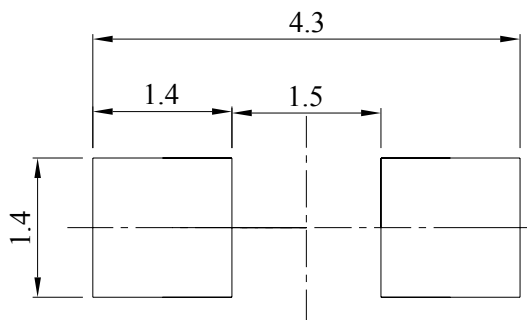

Recommended soldering pad design

Note: The tolerances unless mentioned is $\pm 0.1\text{mm}$;Unit = mm

Technical Data Sheet - Preliminary

Luminosity white Color LED

45-11/B7C-AS2U1E/2T

Absolute Maximum Ratings (Ta=25°C)

Parameter	Symbol	Rating	Unit
Reverse Voltage	V _R	5	V
Forward Current	I _F	30	mA
Peak Forward Current (Duty 1/10 @1KHz)	I _{FP}	100	mA
Power Dissipation	P _d	110	mW
Electrostatic Discharge(HBM)	ESD	2000	V
Operating Temperature	T _{opr}	-40 ~ +85	°C
Storage Temperature	T _{stg}	-40 ~ +90	°C
Soldering Temperature	T _{sol}	Reflow Soldering : 260 °C for 10 sec. Hand Soldering : 350 °C for 3 sec.	

Electro-Optical Characteristics (Ta=25°C)

Parameter	Symbol	Min	Typ	Max	Unit	Condition
Luminous Intensity	I _v	225	-----	565	mcd	I _F =20mA
Viewing Angle	2θ _{1/2}	-----	120	-----	deg	I _F =20mA
Peak Wavelength	λ _p	-----	468	-----	nm	I _F =20mA
Dominant Wavelength	λ _d	464.5	-----	476.5	nm	I _F =20mA
Spectrum Radiation Bandwidth	Δλ	-----	35	-----	nm	I _F =20mA
Forward Voltage	V _F	2.75	-----	3.65	V	I _F =20mA

Notes:

- 1.Tolerance of Luminous Intensity : ±11%
- 2.Tolerance of Dominant Wavelength : ±1nm
- 3.Tolerance of Forward Voltage : ±0.1V

Technical Data Sheet - Preliminary

Luminosity white Color LED

45-11/B7C-AS2U1E/2T**Bin Range of Luminous Intensity**

Bin Code	Min	Max	Unit	Condition
S2	225	285	mcd	I _F =20mA
T1	285	360		
T2	360	450		
U1	450	565		

Bin Range of Dominant Wavelength

Group	Bin Code	Min	Max	Unit	Condition
A	A9	464.5	467.5	nm	I _F =20mA
	A10	467.5	470.5		
	A11	470.5	473.5		
	A12	473.5	476.5		

Bin Range of Forward Voltage

Group	Bin Code	Min	Max	Unit	Condition
E	5	2.75	3.05	V	I _F =20mA
	6	3.05	3.35		
	7	3.35	3.65		

Notes:

- 1.Tolerance of Luminous Intensity : ±11%
- 2.Tolerance of Dominant Wavelength : ±1nm
- 3.Tolerance of Forward Voltage : ±0.1V



Technical Data Sheet - Preliminary

Luminosity white Color LED

45-11/B7C-AS2U1E/2T

Typical Electro-Optical Characteristics Curves

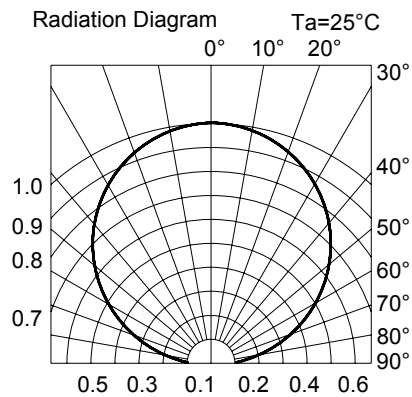
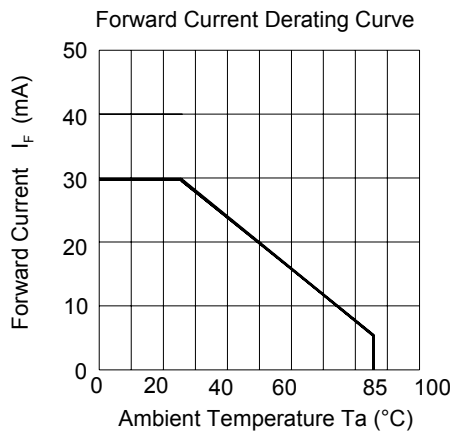
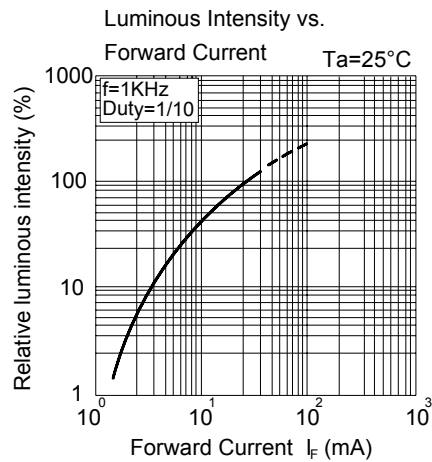
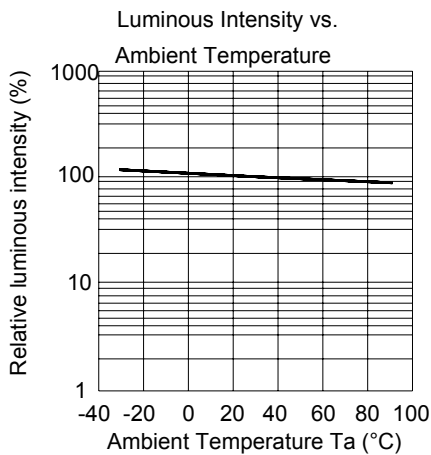
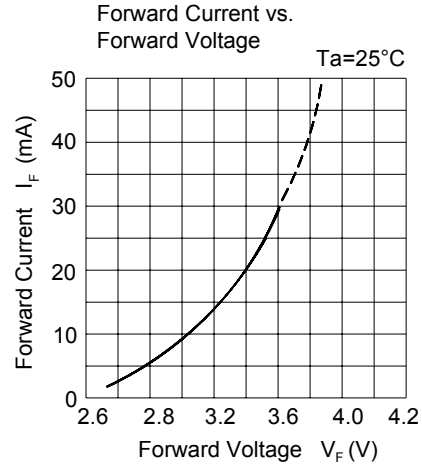
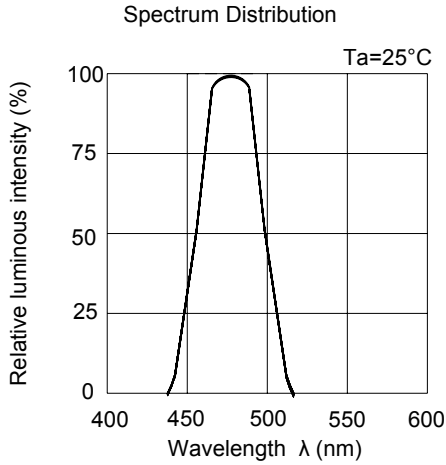



Technical Data Sheet - Preliminary

Luminosity white Color LED

45-11/B7C-AS2U1E/2T

Label Explanation

CAT: Luminous Intensity Rank

HUE: Dom. Wavelength Rank

REF: Forward Voltage Rank

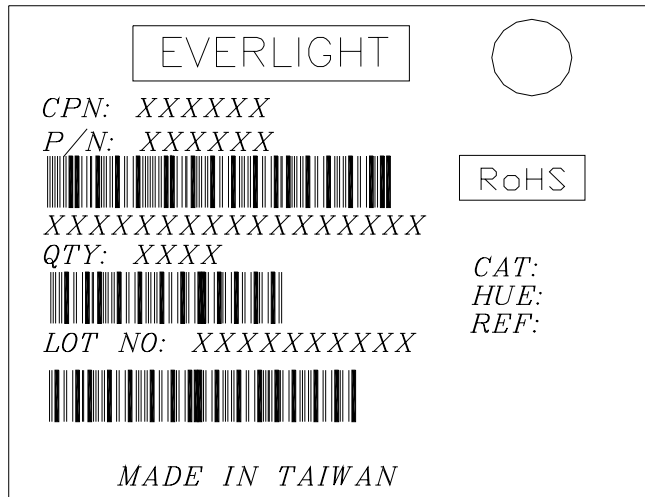

Reel Dimensions

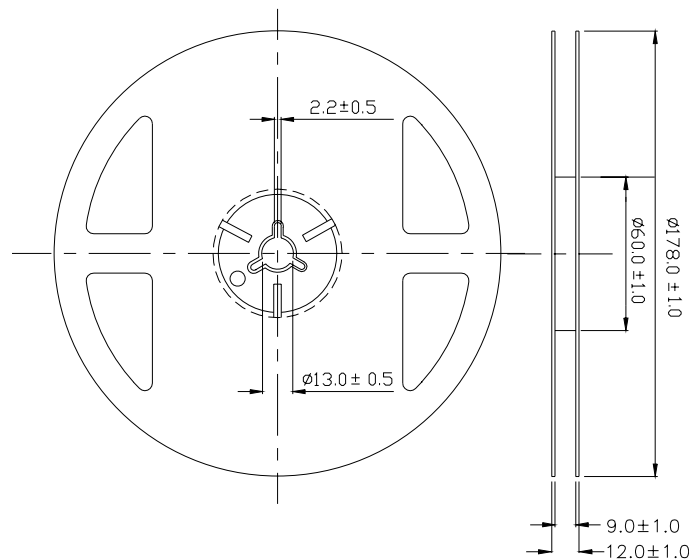

Note: The tolerances unless mentioned is ±0.1mm, Unit = mm

Technical Data Sheet - Preliminary

Luminosity white Color LED

45-11/B7C-AS2U1E/2T

Carrier Tape Dimensions; Loaded Quantity 2000 PCS per reel

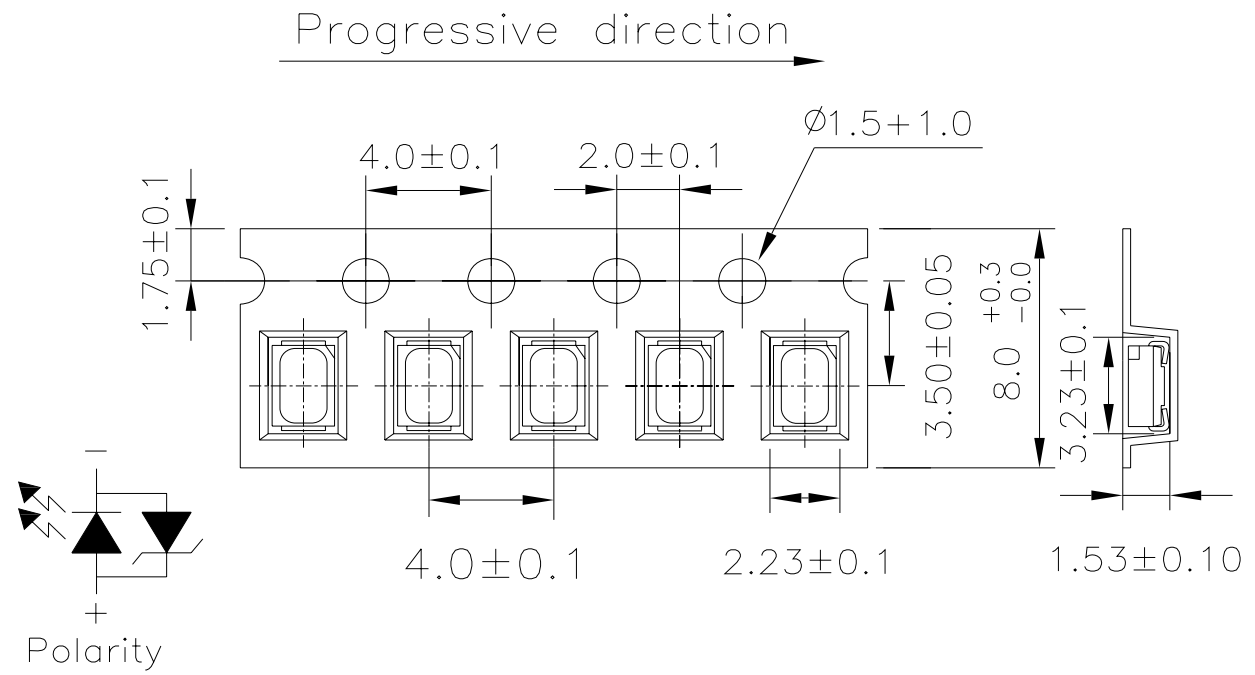

Note: The tolerances unless mentioned is ±0.1mm Unit = mm

Moisture Resistant Packaging

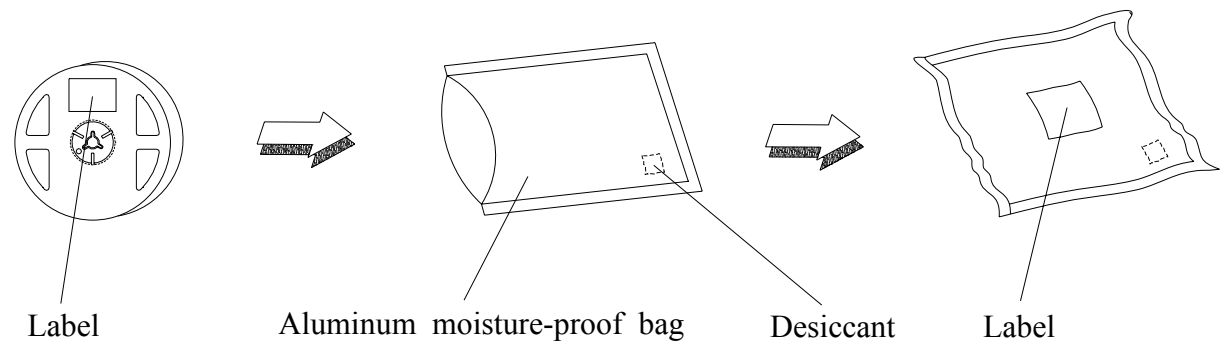

Technical Data Sheet - Preliminary

Luminosity white Color LED

45-11/B7C-AS2U1E/2T**Reliability Test Items And Conditions**

The reliability of products shall be satisfied with items listed below.

Confidence level : 90%

LTPD : 10%

No.	Items	Test Condition	Test Hours/Cycles	Sample Size	Ac/Re
1	Reflow Soldering	Temp. : 260°C±5°C Min. 5sec.	6 Min.	22 PCS.	0/1
2	Temperature Cycle	H : +100°C 15min ∫ 5 min L : -40°C 15min	300 Cycles	22 PCS.	0/1
3	Thermal Shock	H : +100°C 5min ∫ 10 sec L : -10°C 5min	300 Cycles	22 PCS.	0/1
4	High Temperature Storage	Temp. : 100°C	1000 Hrs.	22 PCS.	0/1
5	Low Temperature Storage	Temp. : -40°C	1000 Hrs.	22 PCS.	0/1
6	DC Operating Life	I _F = 20 mA	1000 Hrs.	22 PCS.	0/1
7	High Temperature / High Humidity	85°C / 85%RH	1000 Hrs.	22 PCS.	0/1

Technical Data Sheet - Preliminary

Luminosity white Color LED

45-11/B7C-AS2U1E/2T

Precautions For Use

1. Over-current-proof

Customer must apply resistors for protection , otherwise slight voltage shift will cause big current change (Burn out will happen).

2. Storage

2.1 Do not open moisture proof bag before the products are ready to use.

2.2 Before opening the package: The LEDs should be kept at 30°C or less and 90%RH or less.

2.3 After opening the package: The LED's floor life is 1 year under 30°C or less and 60% RH or less.

If unused LEDs remain, it should be stored in moisture proof packages.

2.4 If the moisture absorbent material (silica gel) has faded away or the LEDs have exceeded the storage time, baking treatment should be performed using the following conditions.

Baking treatment : 60±5°C for 24 hours.

3. Soldering Condition

3.1 Pb-free solder temperature profile

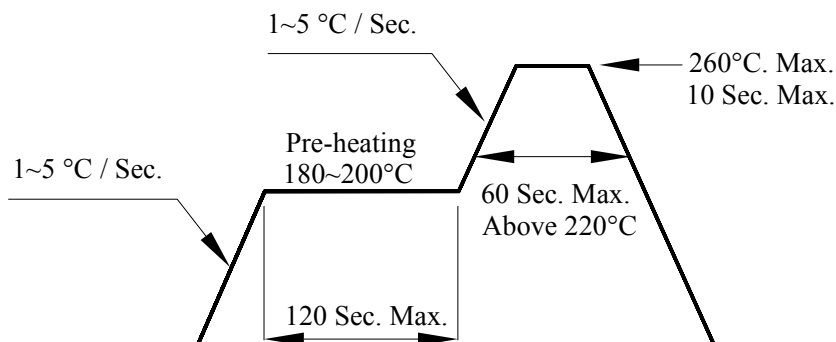

3.2 Reflow soldering should not be done more than two times.

3.3 When soldering, do not put stress on the LEDs during heating.

3.4 After soldering, do not warp the circuit board.

Technical Data Sheet - Preliminary**Luminosity white Color LED****45-11/B7C-AS2U1E/2T****4. Soldering Iron**

Each terminal is to go to the tip of soldering iron temperature less than 350°C for 3 seconds within once in less than the soldering iron capacity 25W. Leave two seconds and more intervals, and do soldering of each terminal. Be careful because the damage of the product is often started at the time of the hand solder.

5. Repairing

Repair should not be done after the LEDs have been soldered. When repairing is unavoidable, a double-head soldering iron should be used (as below figure). It should be confirmed beforehand whether the characteristics of the LEDs will or will not be damaged by repairing.

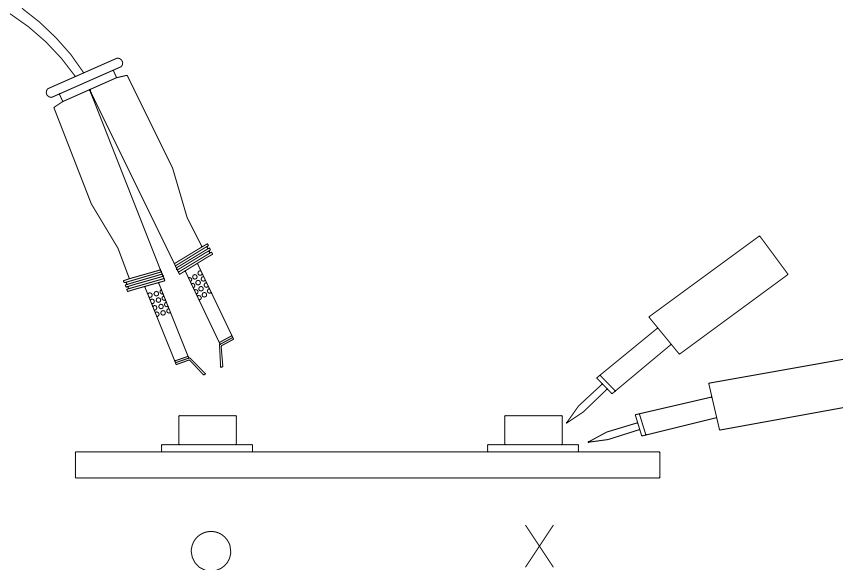
**EVERLIGHT ELECTRONICS CO., LTD.**

Office: No 25, Lane 76, Sec 3, Chung Yang Rd,
Tucheng, Taipei 236, Taiwan, R.O.C

Tel: 886-2-2267-2000, 2267-9936

Fax: 886-2267-6244, 2267-6189, 2267-6306

<http://www.everlight.com>