

1.3 mm Height Subminiature , Axial Flat Top LEDs

MODEL NO : 28-21SRC/TR8

■ Features :

- Package in 12mm tape on 7" diameter reels.
- Compatible with automatic placement equipment.
- Compatible with infrared and vapor phase reflow solder process.
- I.C. compatible.
- EIA std package.
- Mono-color type.

■ Descriptions :

- The 28-21 SMD taping is much smaller than leaded components. Thusenable smaller board size.Higher packing density. Reduced storage space and finally smaller equipment to be obtained.
- Besides, light weight makes them ideal for miniature application, etc.
- Furthermore by automation assembly machines the accuracy is anticipated.

■ Applications :

- Small indicator for outdoor applications.
- Flat backlight for LCD, switch and symbol.
- Indicator and backlight in office equipment.
- Indicator and backlight for battery driven equipment.
- Indicator and backlight for audio and video equipment.
- Automotive : backlighting in dashboard and switch.
- Telecommunication : indicator and backlighting in telephone and fax.
- General use.

■ Package Dimensions :

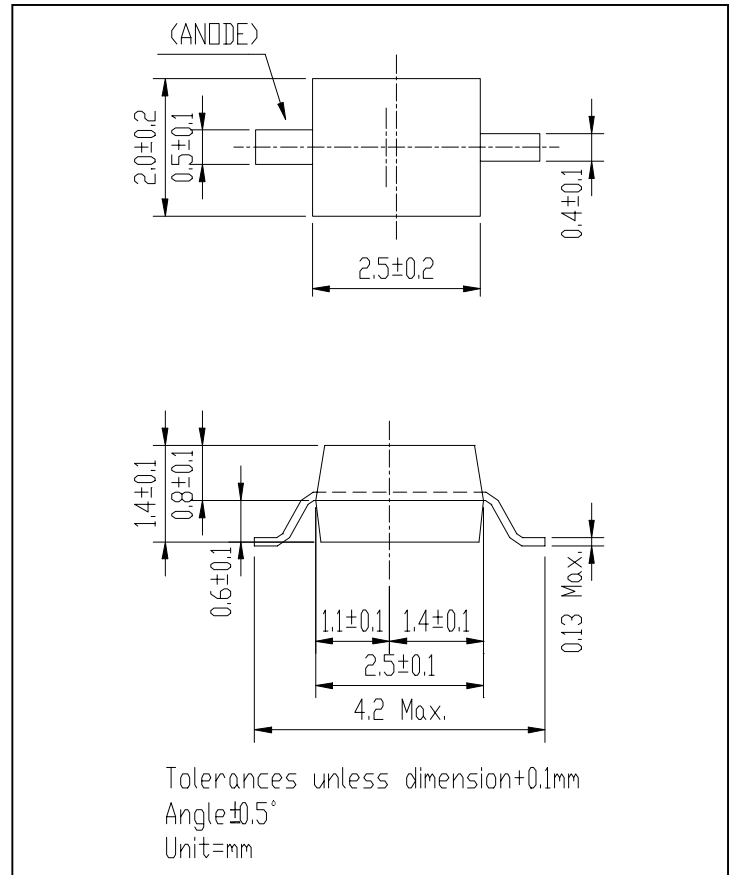

PART NO.	CHIP		Lens Color
	Material	Emitted Color	
28-21SRC/TR8	GaAlAs	Super Red	Water Clear

Office : NO 25,Lane 76, Chung Yang Rd, Sec.3, Tucheng, Taipei 236, Taiwan, R.O.C.

TEL : 886-2-2267-2000,2266-9936(22 Lines)

FAX : 886-2-2267-6189

http: //www.everlight.com



EVERLIGHT ELECTRONICS CO.,LTD.

DEVICE NUMBER : DLE-282-027 REV : 1.2
ECN : _____ PAGE : 2/5

1.3 mm Height Subminiature , Axial Flat Top LEDs

MODEL NO : 28-21SRC/TR8

■ Package Dimensions

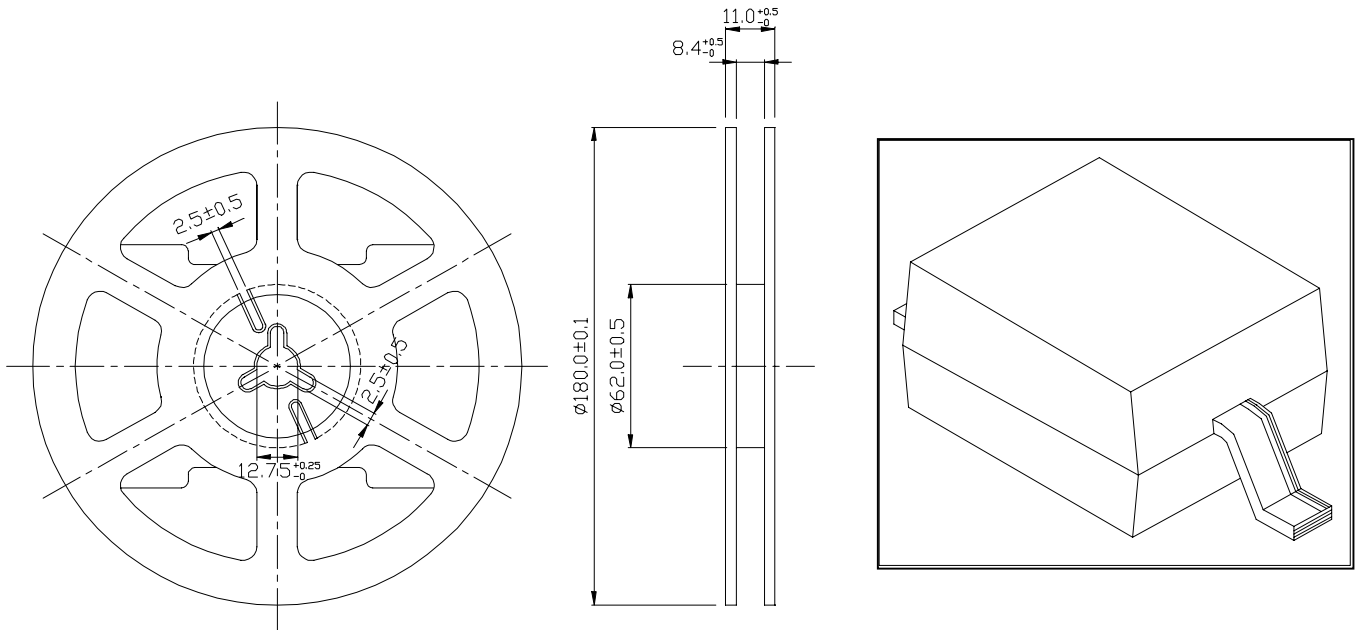

■ Loaded Quantity Per Reel 2000 Pcs/Reel

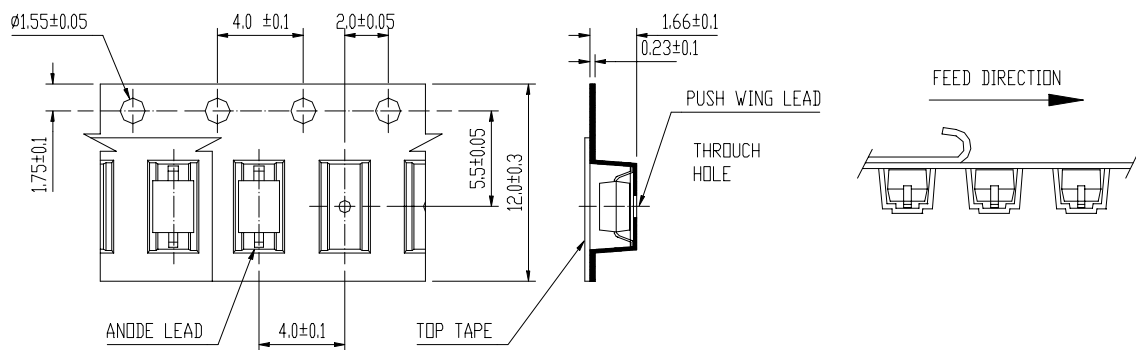

1. All dimensions are in millimeters.
2. Lead spacing is measured where the lead emerge from the package
3. Protruded resin under flange 1.5 mm (0.59") max.



EVERLIGHT ELECTRONICS CO.,LTD.

DEVICE NUMBER : DLE-282-027 REV : 1.2

ECN : _____ PAGE : 3/5

1.3 mm Height Subminiature , Axial Flat Top LEDs

MODEL NO : 28-21SRC/TR8

■ Absolute Maximum Ratings at Ta = 25°C

Parameter	Symbol	Rating	Unit
Reverse Voltage	Vr	5	V
Forward Current	If	40	mA
Operating Temperature	Topr	-40 ~ +85	°C
Storage Temperature	Tstg	-40 ~ +100	°C
Soldering Temperature	Tsol	260 ± 5 for 5 sec	°C
Power Dissipation	Pd	110	mW
Peak Forward Current(Duty 1/10 @ 1KHZ)	If(Peak)	180	mA

■ Electronic Optical Characteristics :

Parameter	Symbol	MIN.	TYP.	MAX.	Unit	Condition
Luminous intensity	Iv	70	100	----	mcd	If = 20 mA
Viewing Angle	2θ 1/2	----	150	----	deg	
Peak Wavelength	λ p	----	660	----	nm	
Dominant Wavelength	λ d	----	643	----	nm	
Spectrum Radiation Bandwidth	△ λ	----	20	----	nm	
Forward Voltage	Vf	1.5	1.7	2.4	V	
Reverse Current	Ir	----	----	10	μ A	Vr=5V



EVERLIGHT ELECTRONICS CO.,LTD.

DEVICE NUMBER : DLE-282-027 REV : 1.2

ECN : _____ PAGE : 4/5

1.3 mm Height Subminiature , Axial Flat Top LEDs

MODEL NO : 28-21SRC/TR8

Reliability Test Item And Condition

NO.	Item	Test Conditions	Test Hours/ Cycle	Sample Size	Ac/Re
1	Solder Heat	TEMP : 260 ± 5	5 sec	76 pcs	0/1
2	Temperature Cycle	H : +85 30 min ↑ 5 min ↓ L : -55 30 min	50 cycle	76 pcs	0/1
3	Thermal Shock	H : +100 5 min ↑ 10 sec ↓ L : -10 30 min	50 cycle	76 pcs	0/1
4	High Temperature Storage	TEMP. : +100	1000 hrs	76 pcs	0/1
5	Low Temperature Storage	TEMP. : -55	1000 hrs	76 pcs	0/1
6	DC Operating Life	If = 20 mA	1000 hrs	76 pcs	0/1
7	High Temperature / High Humidity	85 / 85% R.H.	1000 hrs	76 pcs	0/1



1.3 mm Height Subminiature , Axial Flat Top LEDs

MODEL NO : 28-21SRC/TR8

Typical Electro-Optical Characteristic Curves

