



EVERLIGHT ELECTRONICS CO.,LTD.

DATA SHEET

PART NO. : 19-215/BHC-YL2M2RY/3T

DATE :

DEPARTMENT : R.D.3

REVISION : 1.3

RECEIVED			
MASS PRODUCTION			
PRELIMINARY			
CUSTOMER DESIGN			
DEVICE NUMBER : DSE-195-B01			
PAGE : 12			
CUSTOMER	DESIGNER	CHECKER	APPROVER
	JESSICA CHANG	JEFF TSAI	CHARLES CHANG

REV	DESCRIPTION	RELEASE DATE

OFFICE : NO 25,Lane 76,Chung Yang Rd,Sec.3 Tucheng, Taipei 236, Taiwan, R.O.C.

TEL : 886-2-2267-2000,2266-9936 (22 Lines)

FAX : 886-2-2267-6189

<http://www.everlight.com>



Package Type:

SMD For PCB Type

11-21	19-215
12-21	19-215A
12-215	19-217A
15-21	22-21
15-215	23-21
16-213	23-21B
17-21	24-21
17-215	25-21
19-21	27-21
19-21A	42-21

Dominant Wavelength Groups:

According to the difference wavelength to define
 None: No definition
 A : Standard wavelength definition.
 B : Range of wavelength definition is more narrowly than group A.
 C : Range of wavelength definition is more narrowly than group A, but the value is different with group B.
 F : The wavelength definition in special specification.

The dominant wavelength data did not including ±1nm testing tolerance.

Test Forward Current:

None: 20 mA
 Y : 5 mA
 Z : 10 mA

Taping Quantity:

- 1: 1000 pcs (Taping)
- 2: 2000 pcs (Taping)
- 3: 3000 pcs (Taping)
- 5: 5000 pcs (Taping)
- C : 1500 pcs (Taping)
- D : 10000 pcs (Taping)

Packing Method :

- A: Reverse-side placement (Anode toward the sprocket hole)
- B: Reverse-side placement (Anode toward the sprocket hole)
- C: Right-side placement
- D: Right-side placement (Anode toward the sprocket hole)
- T: Top-side placement
- R: Top-side placement (Anode toward the sprocket hole)

19 - 21 / B H C - A N1 P2 M / 3 T

Emission Color:

- R: Red (λ d: 640nm, 630nm, 625nm)
- S: Sunset Orange (λ d: 615nm, 605nm)
- Y: Yellow (λ d: 595nm, 590nm)
- G: Green (λ d: 570nm, 565nm, 560nm, 525nm, 505nm)
- B: Blue (λ d: 470nm)
- W: White x=0.32 y=0.31

The ordinal number that base on diffence electro-optical characteristics within chip.

1,2 7,8,9, A,B.....X,Y,Z

Resin Color:

- C: Water Clear
- W: White Diffused
- D: Diffused

Luminous Intensity Groups:

- | | | |
|-------------------|-----|-------------------|
| C0: 0.28 ... 0.45 | R ⇨ | R1: 112 ... 140 |
| D0: 0.45 ... 0.70 | S ⇨ | R2: 140 ... 180 |
| E0: 0.70 ... 1.1 | T ⇨ | S1: 180 ... 225 |
| F0: 1.1 ... 1.8 | U ⇨ | S2: 225 ... 285 |
| G0: 1.8 ... 2.8 | V ⇨ | T1: 285 ... 360 |
| H0: 2.8 ... 4.5 | W ⇨ | T2: 360 ... 450 |
| J0: 4.5 ... 7.2 | X ⇨ | U1: 450 ... 565 |
| K0: 7.2 ... 11.5 | Y ⇨ | U2: 565 ... 715 |
| L1: 11.5 ... 14.5 | | V1: 715 ... 900 |
| L2: 14.5 ... 18.0 | | V2: 900 ... 1120 |
| M1: 18.0 ... 22.5 | | W1: 1120 ... 1420 |
| M2: 22.5 ... 28.5 | | W2: 1420 ... 1800 |
| N1: 28.5 ... 36.0 | | X1: 1800 ... 2250 |
| N2: 36.0 ... 45.0 | | X2: 2250 ... 2850 |
| P1: 45.0 ... 57.0 | | Y1: 2850 ... 3600 |
| P2: 57.0 ... 72.0 | | Y2: 3600 ... 4500 |
| Q1: 72.0 ... 90.0 | | |
| Q2: 90.0 ... 112 | | |

Unit: mcd

The luminous intensity data did not including ±15% testing tolerance.

Forward Voltage Groups:

None: No definition

The VF definition as follows:

		Unit: V						
Forward Voltage Group	Bin	Min.	Max.					
C	B	A	00	1.55	1.75			
			0	1.75	1.95			
			1	1.95	2.15			
			2	2.15	2.35			
			3	2.35	2.55			
M	E	D	4	2.55	2.75			
			5	2.75	3.05			
			6	3.05	3.35			
			7	3.35	3.65			
			8	3.65	3.95			
N	F	K	9	2.50	2.70			
			10	2.70	2.90			
			11	2.90	3.10			
			12	3.10	3.30			
			13	3.30	3.50			
			14	3.50	3.70			
			P	H	J	15	2.70	2.85
						16	2.85	3.00
						17	3.00	3.15
						18	3.15	3.30

The forward voltage data did not including ±0.1V testing tolerance.

ANNEX



EVERLIGHT ELECTRONICS CO., LTD.

REV.: 2.0

PAGE: 1/1

■ Dominant Wavelength Groups:

B1				
Dom . Wavelength Of Group	Range			
	Bin	Min.	Max.	Unit
A	A7	458.5	461.5	nm
	A8	461.5	464.5	nm
	A9	464.5	467.5	nm
	A10	467.5	470.5	nm
	A11	470.5	473.5	nm
	A12	473.5	476.5	nm

B3				
Dom . Wavelength Of Group	Range			
	Bin	Min.	Max.	Unit
A	A8	461.5	464.5	nm
	A9	464.5	467.5	nm
	A10	467.5	470.5	nm
	A11	470.5	473.5	nm
	A12	473.5	476.5	nm
	A13	476.5	479.5	nm

BL				
Dom . Wavelength Of Group	Range			
	Bin	Min.	Max.	Unit
A	A5	452.5	455.5	nm
	A6	455.5	458.5	nm
	A7	458.5	461.5	nm
	A8	461.5	464.5	nm
	A9	464.5	467.5	nm

BH						
Dom . Wavelength Of Groups			Range			
			Bin	Min.	Max.	Unit
A			A9	464.5	467.5	nm
			A10	467.5	470.5	nm
			A11	470.5	473.5	nm
			A12	473.5	476.5	nm
V	Z	X	X	465	470	nm
		Y	Y	470	475	nm
		W	W	475	480	nm

■ Forward Voltage Groups:

Forward Voltage Groups				Range			
				Bin	Min.	Max.	Unit
A				00	1.55	1.75	V
				0	1.75	1.95	V
B				1	1.95	2.15	V
				2	2.15	2.35	V
				3	2.35	2.55	V
C				4	2.55	2.75	V
				5	2.75	3.05	V
D				6	3.05	3.35	V
				7	3.35	3.65	V
				8	3.65	3.95	V
E				9	2.50	2.70	V
				10	2.70	2.90	V
F				11	2.90	3.10	V
				12	3.10	3.30	V
				13	3.30	3.50	V
G				14	3.50	3.70	V
				15	2.70	2.85	V
H				16	2.85	3.00	V
				17	3.00	3.15	V
				18	3.15	3.30	V



Technical Data Sheet

0.6mm Height Flat Top LED

19-215/B__C Series *1

Features

- Package in 8mm tape on 7" diameter reel.
- Compatible with automatic placement equipment.
- Compatible with infrared and vapor phase reflow solder process.
- Mono-color type.

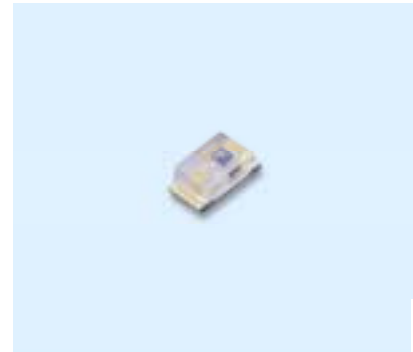

Descriptions

- The 19-215 SMD Taping is much smaller than lead frame type components, thus enable smaller board size, higher packing density, reduced storage space and finally smaller equipment to be obtained.
- Besides, lightweight makes them ideal for miniature applications. etc.

Applications

- Automotive: backlighting in dashboard and switch.
- Telecommunication: indicator and backlighting in telephone and fax.
- Flat backlight for LCD, switch and symbol.
- General use.

Device Selection Guide

Part No.	Chip		Lens Color
	Material	Emitted Color	
19-215/B1C	GaN/SiC	Purplish Blue	Water Clear
19-215/B3C	InGaN/SiC	Blue	
19-215/BLC	InGaN	Deep-Blue	
19-215/BHC		Blue *2	

*1. The series is included 19-215/B1C,19-215/B3C,19-215/BLC, and 19-215/BHC.

*2. Emitted color is distinguished to Dark Blue and Brilliant Blue.

Package Outline Dimensions

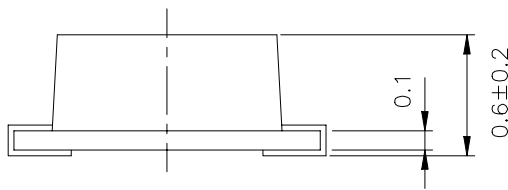
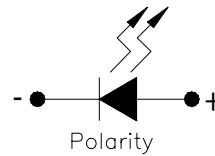
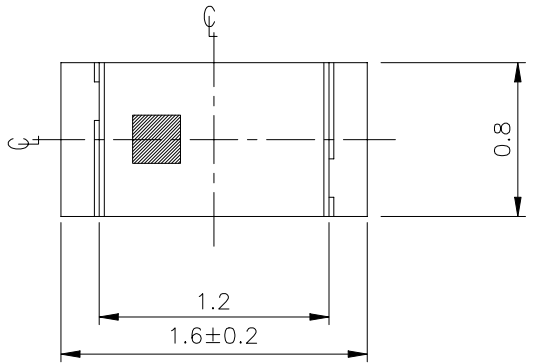

For reflow soldering

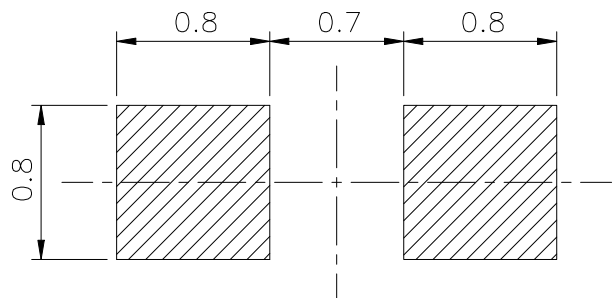
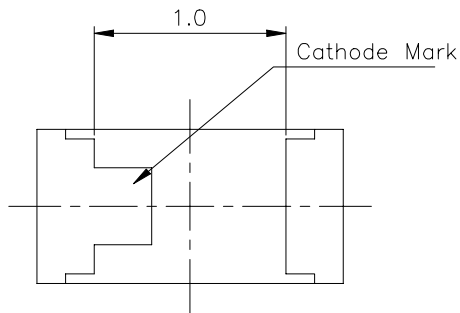

Note: The tolerances unless mentioned is ± 0.1 mm ,Unit = mm

Absolute Maximum Ratings (Ta=25)

Series	Parameter	Symbol	Rating	Unit
19-215/B_C Series	Reverse Voltage	V _R	5	V
19-215/B_C Series	Forward Current	I _F	25	mA
19-215/B1C/B3C			30	
19-215/B_C Series	Operating Temperature	T _{opr}	-40 ~ +85	
19-215/B_C Series	Storage Temperature	T _{stg}	-40 ~ +90	
19-215/B_C Series	Soldering Temperature	T _{sol}	260 (for 5 seconds)	
19-215/B_C Series	Electrostatic Discharge	ESD	150	V
19-215/B1C/B3C			1000	
19-215/B_C Series	Power Dissipation	P _d	110	mW
19-215/B1C/B3C			130	
19-215/B_C Series	Peak Forward Current	I _{FP}	100	mA
19-215/B1C	(Duty 1/10 @1KHz)		70	

Electro-Optical Characteristics (Ta=25)

Part No.	Parameter	Symbol	Min.	Typ.	Max.	Unit	Condition
19-215/B1C	Peak Wavelength	p	----	428	----	nm	If=20mA
19-215/B3C				468			
19-215/BLC				465			
19-215/BHC				468			
19-215/B1C	Dominant Wavelength	d	----	466	----	nm	
19-215/B3C				470			
19-215/BLC				460			
19-215/BHC				470			
19-215/B1C	Spectrum Radiation Bandwidth		----	65	----	nm	
19-215/B3C				26			
19-215/BLC				35			
19-215/BHC				35			
19-215/B_C Series	Viewing Angle	2 1/2	----	120	----	deg	
19-215/B_C Series	Forward Voltage	VF	----	3.5	4.0	V	
19-215/B1C				3.8	4.5		
19-215/B_C Series	Reverse Current	IR	----	----	50	μ A	VR=5V

Notes:
1. Tolerance of Forward Voltage ±0.1V



19-215/B__C Series Explain Of Luminous Intensity:

I_F=20mA

Part No.	Parameter	Symbol	Typ.	Bin Code	Min.	Max.	Unit
19-215/B1C-M1N2	Luminous Intensity	I _v	28	M1	18.0	22.5	mcd
				M2	22.5	28.5	
				N1	28.5	36.0	
				N2	36.0	45.0	
19-215/B3C-M1N2	Luminous Intensity	I _v	26	M1	18.0	22.5	mcd
				M2	22.5	28.5	
				N1	28.5	36.0	
				N2	36.0	45.0	
19-215/BLC-L2N1	Luminous Intensity	I _v	20	L2	14.5	18.0	mcd
				M1	18.0	22.5	
				M2	22.5	28.5	
				N1	28.5	36.0	
19-215/BHC-N1P2	Luminous Intensity	I _v	40	N1	28.5	36.0	mcd
				N2	36.0	45.0	
				P1	45.0	57.0	
				P2	57.0	72.0	
19-215/BHC-N2P2	Luminous Intensity	I _v	55	N2	36.0	45.0	mcd
				P1	45.0	57.0	
				P2	57.0	72.0	
19-215/BHC-P1Q1	Luminous Intensity	I _v	65	P1	45.0	57.0	mcd
				P2	57.0	72.0	
				Q1	72.0	90.0	

Note:The luminous intensity data did not including $\pm 15\%$ testing tolerance.

19-215/B_C Series Explain Of Luminous Intensity:
 $I_F=10mA$

Part No.	Parameter	Symbol	Typ.	Bin Code	Min.	Max.	Unit
19-215/BHC-LN	Luminous Intensity	Iv	20	L	11.5	18.0	mcd
				M	18.0	28.5	
				N	28.5	45.0	
19-215/BHC-MN	Luminous Intensity	Iv	28	M	18.0	28.5	mcd
				N	28.5	45.0	

 $I_F=5mA$

Part No.	Parameter	Symbol	Typ.	Bin Code	Min.	Max.	Unit
19-215/B3C-L1M2	Luminous Intensity	Iv	24	L1	11.5	14.5	mcd
				L2	14.5	18.0	
				M1	18.0	28.5	
				M2	28.5	36.0	
19-215/BHC-K0M	Luminous Intensity	Iv	12	K0	7.2	11.5	mcd
				L	11.5	18.0	
				M	18.0	28.5	
19-215/BHC-L1M1	Luminous Intensity	Iv	17	L1	11.5	14.5	mcd
				L2	14.5	18.0	
				M1	18.0	22.5	
19-215/BHC-L2M2	Luminous Intensity	Iv	22	L2	14.5	18.0	mcd
				M1	18.0	22.5	
				M2	22.5	28.5	
19-215/BHC-MN	Luminous Intensity	Iv	26	M	18.0	28.5	mcd
				N	28.5	45.0	

Note:

The luminous intensity data did not including $\pm 15\%$ testing tolerance.

Typical Electro-Optical Characteristics Curves

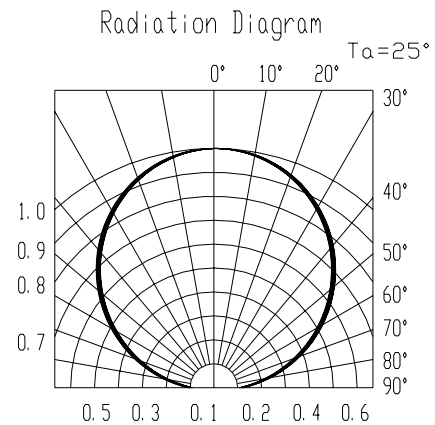
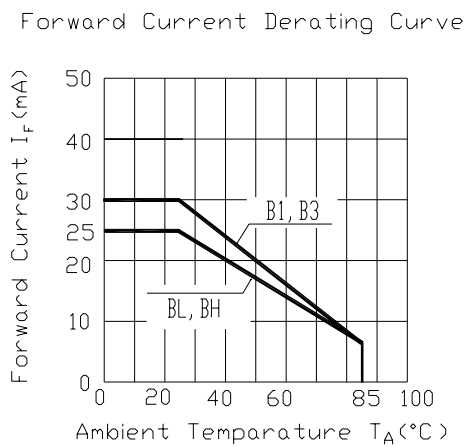
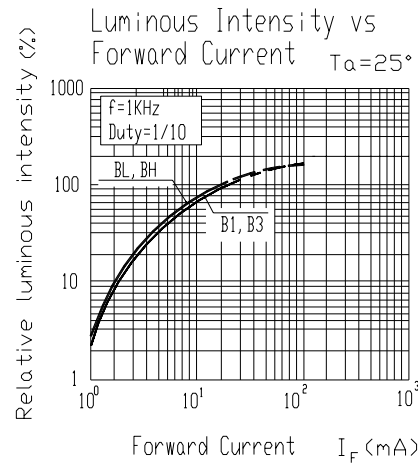
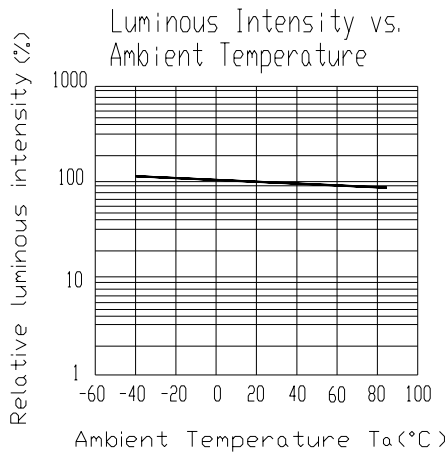
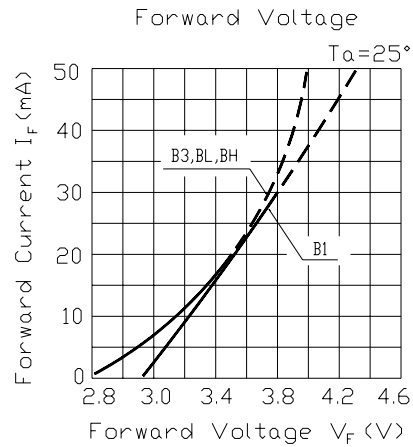
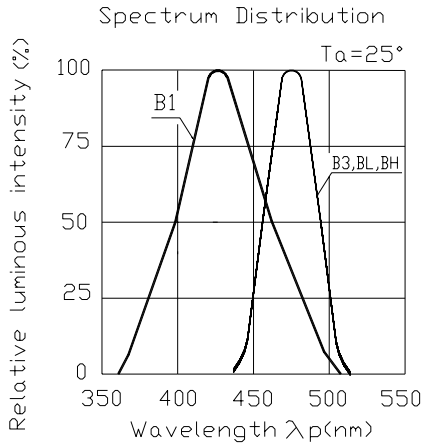

Label explanation

CAT: Luminous Intensity Rank

HUE: Dom. Wavelength Rank

REF: Forward Voltage Rank



Reel Dimensions

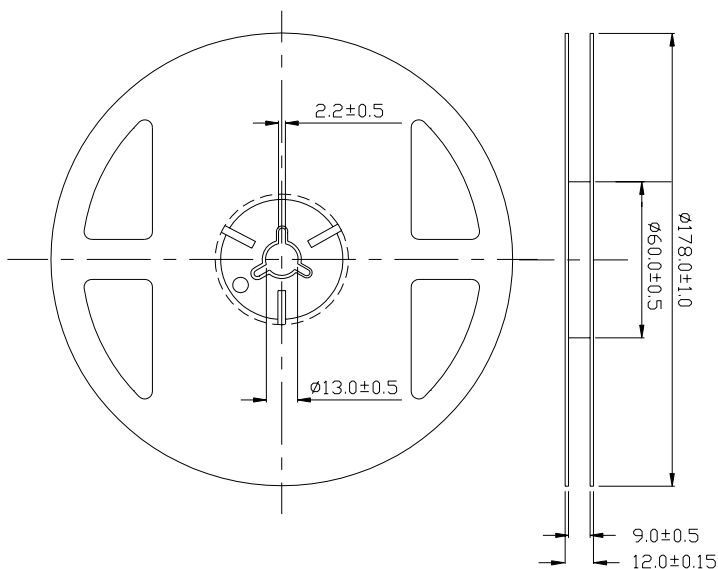

Taping Quantity: 3000pcs

Note: The tolerances unless mentioned is $\pm 0.1\text{mm}$,Unit = mm

Carrier Tape Dimensions

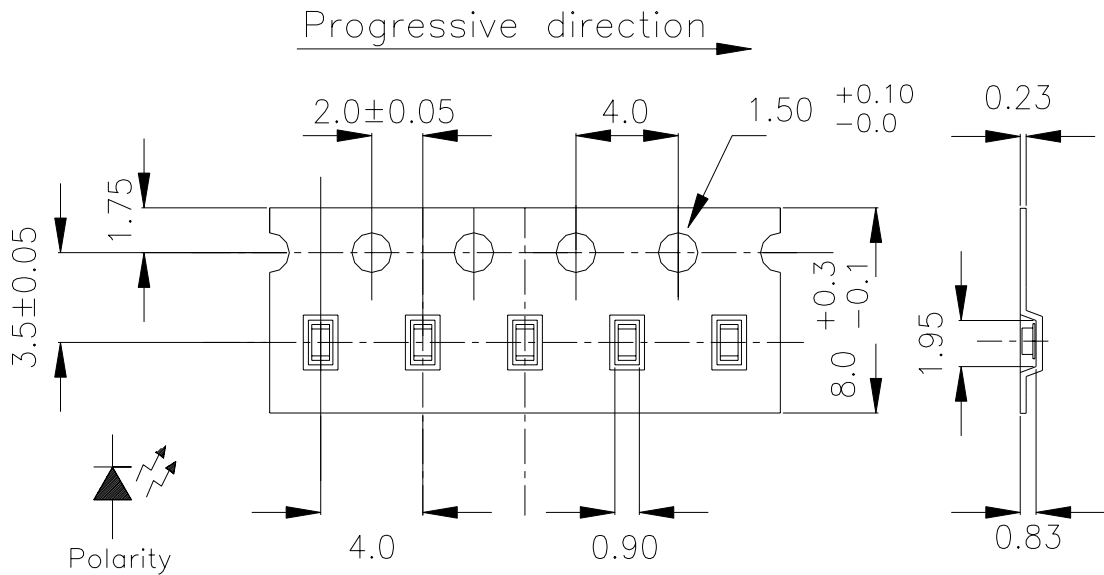

Note: The tolerances unless mentioned is ±0.1mm ,Unit = mm

Moisture Resistant Packaging

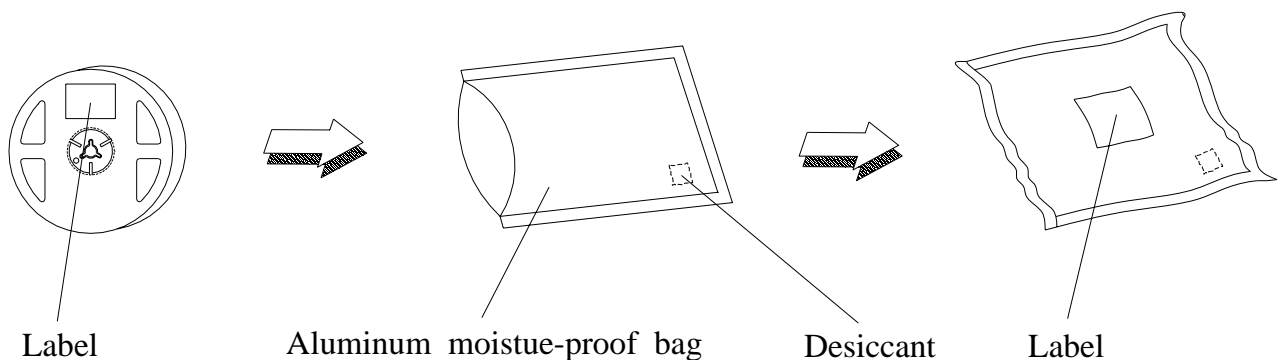

**Reliability Test Items And Conditions**

The reliability of products shall be satisfied with items listed below.

Confidence level : 90%

LTPD : 10%

No.	Items	Test Condition	Test Hours/Cycles	Sample Size	Ac/Re
1	Reflow Soldering	Temp. : 240 ±5 5sec.	6 Min.	22 PCS.	0/1
2	Temperature Cycle	H : +100 15min 5 min L : -40 15min	300 Cycles	22 PCS.	0/1
3	Thermal Shock	H : +100 5min 10 sec L : -10 5min	300 Cycles	22 PCS.	0/1
4	High Temperature Storage	Temp. : 100	1000 Hrs.	22 PCS.	0/1
5	Low Temperature Storage	Temp. : -55	1000 Hrs.	22 PCS.	0/1
6	DC Operating Life	IF = 20 mA	1000 Hrs.	22 PCS.	0/1
7	High Temperature / High Humidity	85 /RH85%	1000 Hrs.	22 PCS.	0/1

Precautions For Use

1. Over-current-proof

Customer must apply resistors for protection , otherwise slight voltage shift will cause big current change (Burn out will happen).

2. Storage

- 2.1 Do not open moisture proof bag before the products are ready to use.
- 2.2 Before opening the package, the LEDs should be kept at 30 or less and 90%RH or less.
- 2.3 The LEDs should be used within a year.
- 2.4 After opening the package, the LEDs should be kept at 30 or less and 70%RH or less.
- 2.5 The LEDs should be used within 168 hours (7 days) after opening the package.
- 2.6 If the moisture absorbent material (silica gel) has faded away or the LEDs have exceeded the storage time, baking treatment should be performed using the following conditions.
Baking treatment : 60±5 for 24 hours.

3. Soldering Condition

3.1 Lead solder temperature profile

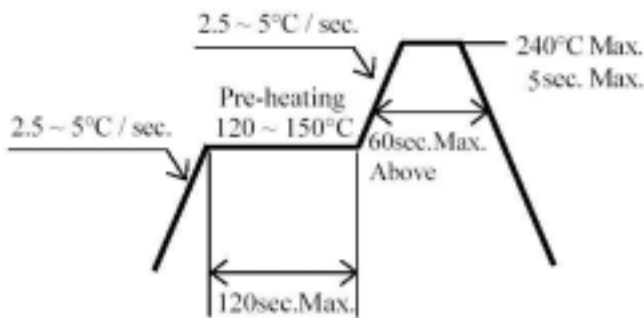

- 3.2 Reflow soldering should not be done more than two times.
- 3.3 When soldering, do not put stress on the LEDs during heating.
- 3.4 After soldering, do not warp the circuit board.

4. Soldering Iron

Each terminal is to go to the tip of soldering iron temperature less than 280 for 3 seconds within once in less than the soldering iron capacity 25W. Leave two seconds and more intervals, and do soldering of each terminal. Be careful because the damage of the product is often started at the time of the hand solder.

5.Repairing

Repair should not be done after the LEDs have been soldered. When repairing is unavoidable, a double-head soldering iron should be used (as below figure). It should be confirmed beforehand whether the characteristics of the LEDs will or will not be damaged by repairing.

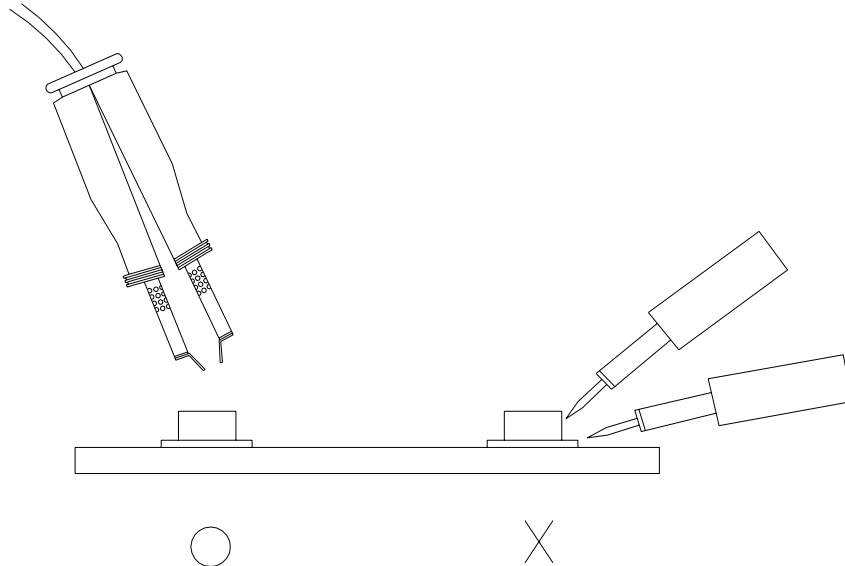

EVERLIGHT ELECTRONICS CO., LTD.
Office: No 25, Lane 76, Sec 3, Chung Yang Rd,
Tucheng, Taipei 236, Taiwan, R.O.C

Tel: 886-2-2267-2000, 2267-9936
Fax: 886-2267-6244, 2267-6189, 2267-6306
<http://www.everlight.com>